

A-A (1 : 1)

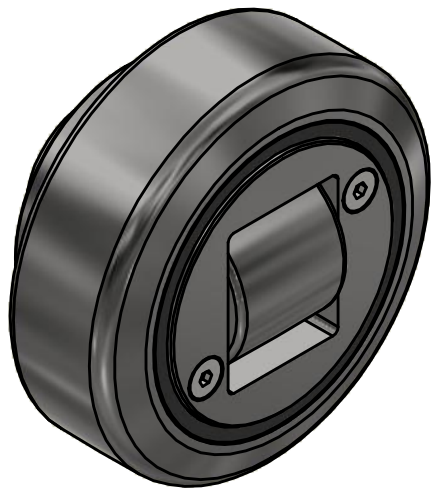
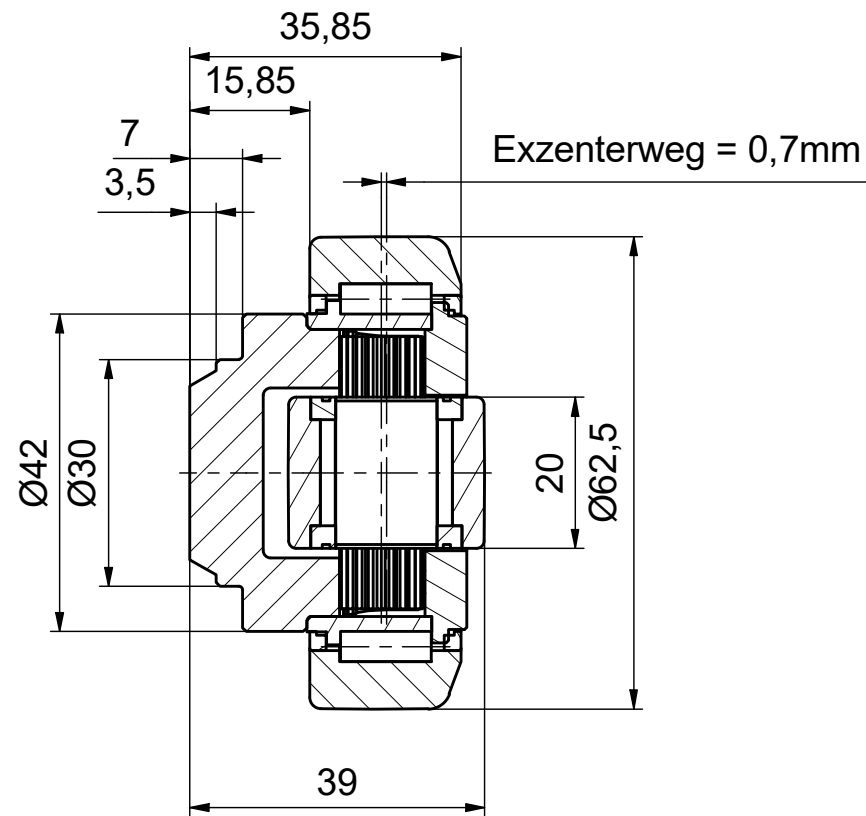

<p>Alfatec-Str. 1 D-70794 Filderstadt Tel.: +49 711 907 400-0 Mail: mail@alfatec.biz www.alfatec.biz</p>	Typschlüssel/type code: TR 060.0350 Ø 62,5 mm mit Axialrolle - justierbar mit Exzenter		
	Beschreibung/description: Tigerrolle		
<small> Allgmeintoleranz nach DIN ISO 2768-1m, DIN ISO 2768-2k oder DIN ISO 13920-1. Werkstückkanten nach DIN ISO 13715. Schutzvermerke nach DIN 34 beachten. General tolerance after DIN ISO 2768-1m, DIN ISO 2768-2k or DIN ISO 13920-1. Partnote according to DIN ISO 13715 Protection note according to DIN 34 consider. </small>	Referenz-Nr./reference number: 1000008280	Maßstab/scale: 1 : 1	Blatt/page: 1 von 1
			Gewicht/weight: 0,5 kg