



Manual Positioners 2016



Manual Positioners



GMT GLOBAL INC.

No. 3, Lane 34, Minju Street, Shioushuei Township, Changhua 50442, Taiwan.

TEL : +886-4-768-8320

FAX : +886-4-768-8314

E-mail : sales@gmtlinear.com

Europe Branch

GMT Europe GmbH

Wilhelm-Busch-Str. 4, 26655 Westerstede.

TEL : 04488-520-30-47













E-mail : info@gmteurope.de



www.gmtlinear.com



GMT GLOBAL INC.

1	Support Units		7	Precision Alignment Stages	
2	Couplings		8	Motor / Driver	
3	Guides & Bearings		9	Lock Nuts	
4	Positioning Stages		10	Ball Screws	
5	Standard Motorized Stages		11	XY-TABLE Linear Stages	
6	Precision Motorized Stages		12	Linear Actuators	

Thanks for interesting in GMT Manual Positioners.

In this catalogue, you will find our category 4 as shown in specified colors.

Category 1, 2, 3, 9, and 10 will be found in another catalogue Linear Motion Components.

Category 5, 6, 7, 8, 11, and 12 will be found in another catalogue Motorized Positioners.

Most update product data will be available to be download from our website.



Great Motion Tech



GMT GLOBAL INC. Enthusiasm . United . Innovation . Brilliant

The best partner of Motion Technical, GMT, devote itself to research & development and design, system plan, as to production needs, try to be the best cooperate partner and reliable ally through coordination development with clients, to satisfy Automatic Equipment and Precision Measuring related industries. Choosing Made in Taiwan GMT products integrated to your products, safe and ease are secured.

GMT insists on core value "Service, Quality, R&D", and regard high technical and high precision product development as our mission, to stride toward to be the World-Class Precision Linear Motion Enterprise as our main goal.



4

Positioning Stages

Positioning Stages-Product Introduction

- ◆Characteristic of Different Guiding Type : P.0031~P.0032
- ◆Stage Brief Outline / Feed Mode Introduction : P.0033~P.0034
- ◆Precision Inspection Method. : P.0035~P.0037
- ◆Assembly Scheme : P.0038~P.0040
- ◆Usage Caution : P.0041~P.0042
- ◆Model No. Description : P.0043
- ◆Feeding Position : P.0044
- ◆Dovetail Guiding Model No. Description : P.0199













Micrometer-Product Introduction

- ◆Micrometer Introduction : P.0315
- ◆Micrometer Model No. Description : P.0316

Feeding Screw-Product Introduction















- ◆Feeding Screw Introduction : P.0327
- ◆Feeding Screw Model No. Description : P.0328

Positioning Stages-Specification Introduction

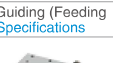
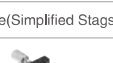
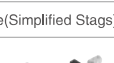
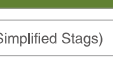
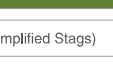
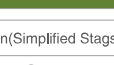
<p>Crossed Roller Stages</p> <p>X-axis & XY-axis Aluminum alloy</p>  <p>MX(Y)-AC(S) P.0047~P.0066</p>	<p>Crossed Roller Stages</p> <p>Z-axis Aluminum alloy</p>  <p>MZL-ACR(AS) P.0067~P.0070</p>	<p>Crossed Roller Stages</p> <p>XZ-axis Aluminum alloy</p>  <p>MXZ-A P.0071</p>
<p>Crossed Roller Stages</p> <p>XYZ-axis Aluminum alloy</p>  <p>MXYZ-A P.0072</p>	<p>Crossed Roller Stages</p> <p>Aluminum alloy</p>  <p>Multiple axes P.0073~P.0074</p>	<p>Crossed Roller Stages</p> <p>X-axis & XY-axis Thin type Aluminum alloy</p>  <p>MX(Y)L-AC(S)-18 P.0075~P.0084</p>
<p>Crossed Roller Stages</p> <p>Z-axis Thin type Aluminum alloy</p>  <p>MLZ-ASZ P.0085~P.0086</p>	<p>Crossed Roller Stages</p> <p>XY-axis Thin type Aluminum alloy</p>  <p>MYW-AC(S) P.0087~P.0090</p>	<p>Crossed Roller Stages (Feeding screw design)</p> <p>X-axis & XY-axis Aluminum alloy</p>  <p>MX(Y)-AC(S)-18 P.0091~P.0108</p>
<p>Crossed Roller Stages New Specifications</p> <p>X-axis Aluminum alloy</p>  <p>MX764-AC-SHR P.0109</p>	<p>Crossed Roller Stages New Specifications</p> <p>XYZ-axis Aluminum alloy</p>  <p>MBZ-AML P.0110~P.0111</p>	<p>Crossed Roller Stages New Specifications</p> <p>XY-axis Aluminum alloy</p>  <p>MYCP-A P.0112~P.0113</p>

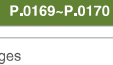



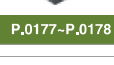















4

Positioning Stages

<p>Crossed Roller Stages(Feeding Screw Design) New Specifications</p> <p>XYZ-axis Prober stages Aluminum alloy</p>  <p>MPS-AMR(L-18) P.0114~P.0116</p>	<p>Crossed Roller Stages(Feeding Screw Design) New Specifications</p> <p>X-axis Heavy loading Carbon steel</p>  <p>MXTH80-FCS P.0117~P.0118</p>	<p>Linear Ball Bearing Guiding</p> <p>X-axis & XY-axis Stainless steel</p>  <p>MX(Y)-SC(S) P.0119~P.0134</p>
<p>Linear Ball Bearing Guiding</p> <p>Z-axis Stainless steel</p>  <p>MZL-SCR P.0135~P.0136</p>	<p>Linear Ball Bearing Guiding</p> <p>Z-axis Stainless steel</p>  <p>MZL-SS P.0137~P.0138</p>	<p>Linear Ball Bearing Guiding</p> <p>XY-axis Ultra thin type Stainless steel</p>  <p>MYW-SS(C) P.0139~P.0142</p>
<p>Linear Ball Bearing Guiding</p> <p>XZ-axis Stainless steel</p>  <p>MXZ-S P.0143</p>	<p>Linear Ball Bearing Guiding</p> <p>XYZ-axis Stainless steel</p>  <p>MXYZ-S P.0144</p>	<p>Linear Ball Bearing Guiding (Feeding Screw Design)</p> <p>X-axis & XY-axis Stainless steel</p>  <p>MX(Y)-SC(S)-28 P.0145~P.0160</p>
<p>Linear Ball Bearing Guiding (Feeding Screw Design) New Specifications</p> <p>X-axis Stainless steel</p>  <p>MX60L-SS-28 P.0161~P.0162</p>	<p>Feeding Screw Type(Simplified Stags)</p> <p>X-axis Mini type</p>  <p>MNG1E-CL P.0163~P.0164</p>	<p>Feeding Screw Type(Simplified Stags)</p> <p>XY-axis Mini type</p>  <p>MNG2E-CL P.0165~P.0166</p>
<p>Leadscrew Type(Simplified Stags)</p> <p>X-axis Mini type</p>  <p>MNE1E P.0167~P.0168</p>	<p>Leadscrew Type(Simplified Stags)</p> <p>XY-axis Mini type</p>  <p>MNE2E P.0169~P.0170</p>	<p>Optional Combination(Simplified Stags)</p> <p>X-axis Mini type</p>  <p>MNE1E P.0171~P.0172</p>
<p>Micro-Designed Type(Simplified Stags)</p> <p>X-axis & XY-axis Mini type</p>  <p>MN-A P.0173~P.0174</p>	<p>Crossed Roller Stages</p> <p>Horizontal Z-axis</p>  <p>MZA-(H) P.0175~P.0176</p>	<p>Crossed Roller Stages</p> <p>Horizontal Z-axis</p>  <p>MZA-5060 P.0177~P.0178</p>
<p>Laboratory Jacks</p> <p>Z-axis</p>  <p>MZF P.0179~P.0180</p>	<p>Rotary Stages(Precision Type)</p> <p>θ-axis</p>  <p>AR-AR P.0181~P.0182</p>	<p>Rotary Stages(Precision Type)</p> <p>θ-axis Thin type</p>  <p>MRL-AL P.0183~P.0184</p>

















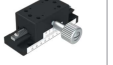



4

Positioning Stages

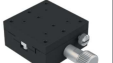
<p>Rotary Stages(Economic Type) New Specifications</p> <p>θ-axis</p>  <p>MR50-AR-48 P.0185</p>	<p>Rotary Stages(Economic Type)</p> <p>θ-axis</p>  <p>MR85-S P.0185</p>	<p>Rotary Stages(Economic Type)</p> <p>θ-axis</p>  <p>MRE-A P.0186~P.0187</p>
<p>Magnetic base</p> <p>Thin type</p>  <p>MMT- P.0188</p>	<p>Magnetic Base</p>  <p>MMS- P.0189~P.0190</p>	<p>Feeding Screw Type(Tilt Stage)</p>  <p>MTB- P.0191~P.0192</p>
<p>Thumb Screw(Tilt Stage)</p>  <p>MTS- P.0193~P.0194</p>	<p>Adapting Bracket</p> <p>For Z-axis application</p>  <p>AZB- P.0195~P.0196</p>	<p>Adjustable Spacer</p>  <p>ASAP- P.0197</p>
<p>Adaptor Plate</p>  <p>AIB- EAIB- P.0198</p>	<p>Feeding Screw Type(Dovetail Guiding)</p> <p>X-axis</p>  <p>MC1A- P.0200</p>	<p>Feeding Screw Type(Dovetail Guiding)</p> <p>XY-axis</p>  <p>MC2A- P.0201</p>
<p>Feeding Screw Type(Dovetail Guiding)</p> <p>Z-axis</p>  <p>MC4A- P.0202</p>	<p>Feeding Screw Type(Dovetail Guiding) New Specifications</p> <p>X-axis Thin type Lead:4.2 mm</p>  <p>MC1A-A P.0203</p>	<p>Feeding Screw Type(Dovetail Guiding)</p> <p>X-axis Thin type Lead:4.2 mm</p>  <p>MC4A-A60 P.0204</p>
<p>Feeding Screw Type(Dovetail Guiding)</p> <p>X-axis & XY-axis Thin type Lead:4.2 mm</p>  <p>MC-A-60CL P.0205</p>	<p>Feeding Screw Type(Dovetail Guiding) New Specifications</p> <p>X-axis Thin type Lead:4.2 mm</p>  <p>MC1A-L P.0206</p>	<p>Feeding Screw Type(Dovetail Guiding) New Specifications</p> <p>X-axis Clamping type Lead:4.2 mm</p>  <p>MC1A-46C P.0207</p>
<p>Feeding Screw Type(Dovetail Guiding)</p> <p>X-axis Lead:4.2 mm</p>  <p>MC1A-S P.0208</p>	<p>Feeding Screw Type(Dovetail Guiding)</p> <p>XY-axis Lead:4.2 mm</p>  <p>MC2A-S P.0209</p>	<p>Feeding Screw Type(Dovetail Guiding)</p> <p>Z-axis Lead:4.2 mm</p>  <p>MC4A-49S P.0210</p>

















4

Positioning Stages

<p>Feeding Screw Type(Dovetail Guiding)</p> <p>X-axis Lead:4.2 mm</p>  <p>MC1A-425 P.0211</p>	<p>Feeding Screw Type(Dovetail Guiding)</p> <p>X-axis & Z-axis Lead:0.5 mm</p>  <p>MC-AL-40 P.0212</p>	<p>Feeding Screw Type(Dovetail Guiding)</p> <p>X-axis Lead:4.2 mm</p>  <p>MC1A-48KM(R) P.0213~P.0214</p>
<p>Rack and Pinion Type (Dovetail Guiding)</p> <p>X-axis</p>  <p>MC1B- P.0215</p>	<p>Rack and Pinion Type (Dovetail Guiding)</p> <p>XY-axis</p>  <p>MC2B- P.0216</p>	<p>Rack and Pinion Type (Dovetail Guiding)</p> <p>Z-axis</p>  <p>MC4B- P.0217</p>
<p>Rack and Pinion Type (Dovetail Guiding) New Specifications</p> <p>X-axis</p>  <p>MC1B-60F P.0218</p>	<p>Rack and Pinion Type (Dovetail Guiding)</p> <p>X-axis Long stroke</p>  <p>MC1C- P.0219~P.0220</p>	<p>Rack and Pinion Type (Dovetail Guiding)</p> <p>X-axis Long stroke</p>  <p>MC1C-2 P.0221~P.0222</p>
<p>Rack and Pinion Type (Dovetail Guiding)</p> <p>Z-axis Long stroke</p>  <p>MC3C- P.0223</p>	<p>Rack and Pinion Type (Dovetail Guiding)</p> <p>Z-axis Long stroke</p>  <p>MC3C-2 P.0224</p>	<p>Rack and Pinion Type (Dovetail Guiding)</p> <p>Z-axis Long stroke</p>  <p>MC3C-300-3 P.0225</p>
<p>Rack and Pinion Type (Dovetail Guiding)</p> <p>X-axis</p>  <p>MC1D- P.0226</p>	<p>Rack and Pinion Type (Dovetail Guiding)</p> <p>XY-axis</p>  <p>MC2D- P.0227</p>	<p>Rack and Pinion Type (Dovetail Guiding)</p> <p>Z-axis</p>  <p>MC4D- P.0228</p>
<p>Rack and Pinion Type (Dovetail Guiding)</p> <p>X-axis</p>  <p>MC1D-40L P.0229</p>	<p>Rack and Pinion Type (Dovetail Guiding)</p> <p>XY-axis</p>  <p>MC2DA-48NH P.0230</p>	<p>Rack and Pinion Type (Dovetail Guiding)</p> <p>Horizontal Z-axis</p>  <p>MC3B- P.0231</p>
<p>Rack and Pinion Type (Dovetail Guiding)</p> <p>XZ-axis X-axis: Feeding screw Z-axis: Rack and pinion type</p>  <p>MC5B- P.0232</p>	<p>Rack and Pinion Type (Dovetail Guiding)</p> <p>XY-axis</p>  <p>MC1BL-60 P.0233~P.0234</p>	<p>Rack and Pinion Type (Dovetail Guiding)</p> <p>X-axis</p>  <p>MCS-(W) P.0235~P.0236</p>





















4

Positioning Stages

<p>Rack and Pinion Type (Dovetail Guiding) XY-axis</p>  <p>MCD-□(W) P.0237~P.0238</p>	<p>Rack and Pinion Type (Dovetail Guiding) Z-axis</p>  <p>MCV-□(W) P.0239~P.0240</p>	<p>Rack and Pinion Type (Dovetail Guiding) Z-axis</p>  <p>MCV-□(W)L P.0241~P.0242</p>
<p>Rack and Pinion Type (Dovetail Guiding) X+Z-axis</p>  <p>MCM-□(W) P.0243~P.0244</p>	<p>Rack and Pinion Type (Dovetail Guiding) X+Z-axis</p>  <p>MCM-□(W)L P.0245~P.0246</p>	<p>Rack and Pinion Type (Dovetail Guiding) XY+Z-axis</p>  <p>MCT-□(W) P.0247~P.0248</p>
<p>Rack and Pinion Type (Dovetail Guiding) XY+Z-axis</p>  <p>MCT-□(W)L P.0249~P.0250</p>	<p>Rack and Pinion Type (Dovetail Guiding) X & XY & Z & X+Z & XY+Z-axis</p>  <p>MC□D-2550 P.0251~P.0252</p>	<p>Feeding Screw Type (Dovetail Guiding) X & XY-axis Hex. wrench design</p>  <p>MC□E-□ P.0253~P.0254</p>
<p>Feeding Screw Type (Dovetail Guiding) Z-axis Hex. wrench design</p>  <p>MC4E-□ P.0255~P.0256</p>	<p>Feeding Screw Type (Dovetail Guiding) XY+Z-axis Hex. wrench design</p>  <p>MC6E-25 P.0257</p>	<p>Feeding Screw Type (Dovetail Guiding) X-axis</p>  <p>MC1G-525C(F) P.0258</p>
<p>Feeding Screw Type (Dovetail Guiding) New Specifications X-axis</p>  <p>MC1G-535C(F) P.0259</p>	<p>Feeding Screw Type+Rack and Pinion Type (Dovetail Guiding) New Specifications XX-axis</p>  <p>MC7G-4050C(F) P.0260</p>	<p>Rack and Pinion Type (Dovetail Guiding) New Specifications X-axis</p>  <p>MC1B-35LG P.0261</p>
<p>Rack and Pinion Type (Dovetail Guiding) New Specifications XYZ-axis</p>  <p>MC6B-35LG P.0262</p>	<p>Crossed Roller Stages (Dovetail Guiding) New Specifications X-axis</p>  <p>MC1F-40 P.0263~P.0264</p>	<p>Dovetail Goniometer Stage α-axis</p>  <p>MXG□-□CS P.0265~P.0266</p>
<p>Dovetail Goniometer Stage αβ-axis</p>  <p>MYG□-□CS P.0267~P.0268</p>	<p>Dovetail Goniometer Stage α & αβ-axis</p>  <p>MX(Y)G5-□CS P.0269~P.0270</p>	<p>Dovetail Goniometer Stage New Specifications α-axis</p>  <p>MXG9-118C P.0271~P.0272</p>









4

Positioning Stages

<p>Dovetail Goniometer Stage α & αβ-axis</p>  <p>MXG3-□CE P.0273~P.0274</p>	<p>Dovetail Goniometer Stage α & αβ-axis</p>  <p>MX(Y)G4-□CE P.0275~P.0276</p>	<p>Dovetail Goniometer Stage α & αβ-axis</p>  <p>MX(Y)G6-□CE P.0277~P.0278</p>
<p>Dovetail Goniometer Stage New Specifications α-axis</p>  <p>MXG□-□VM P.0279~P.0280</p>	<p>Dovetail Goniometer Stage New Specifications α-axis</p>  <p>MXG6-□VM P.0281~P.0282</p>	<p>Feeding Screw Drive New Specifications X-axis Vice clamping fixture</p>  <p>MCV100-AS P.0283~P.0284</p>
<p>Manual Fiber Positioning XYZ-axis</p>  <p>M3E-2000S-L(R) P.0285~P.0288</p>	<p>Manual Fiber Positioning XYZ θ x θ y-axis</p>  <p>M5E-2000B-L(R) P.0289~P.0292</p>	<p>Manual Fiber Positioning XYZ θ x θ y θ z-axis Long stroke</p>  <p>M6E-2200B-L(R) P.0293~P.0296</p>
<p>Manual Fiber Positioning XYZ θ x θ y-axis</p>  <p>M5F-460A561-L(R) P.0297~P.0300</p>	<p>Manual Fiber Positioning θxθy-axis Tilt Stage</p>  <p>MTS-561-L(R) P.0301~P.0304</p>	<p>Manual Fiber Positioning XY-axis Crossed Roller Guiding Type</p>  <p>MXY-460AL(R) P.0305~P.0308</p>
<p>Manual Fiber Positioning XYZ-axis Crossed Roller Guiding Type</p>  <p>MXYZ-460AL(R) P.0309~P.0312</p>	<p>Optical Adjuster New Specifications Vertical Mounting</p>  <p>MOVMS-□ P.0313~P.0314</p>	<p>Micrometer Specification Stroke 0~6.5</p>  <p>MHGS-F(S)(P)-6.5 P.0317</p>
<p>Micrometer Specification Stroke 0~13</p>  <p>MHGS-F(S)(P)-13 P.0318</p>	<p>Micrometer Specification Stroke 0~15</p>  <p>MHGS-F(S)(P)-15 P.0319</p>	<p>Micrometer Specification Stroke 0~25</p>  <p>MHGS-F(S)(P)-25 P.0320</p>
<p>Micrometer Specification Stroke 0~50</p>  <p>MHGS-F(S)(P)-50 P.0321</p>	<p>Micrometer Specification Stroke 0~6.5</p>  <p>MHGS-SP-6.5A(B) P.0322</p>	<p>Micrometer Specification Stroke 0~25</p>  <p>MHGS-F(S)(P)-25A P.0322</p>

4

Positioning Stages

<p>Micrometer Specification Inch Specifications</p>  <p>MHGS-FN-□ P.0323</p>	<p>Micrometer Specification New Specifications Stroke 0~13 Economic type</p>  <p>EMHGS-F(S)N(P)-13 P.0324</p>	<p>Micrometer Specification New Specifications Stroke 0~25 Economic type</p>  <p>EMHGS-F(S)N(P)-25 P.0325</p>
<p>Feeding Screw Stages New Specifications</p>  <p>PS1R-□ P.0329</p>	<p>Feeding Screw Stages New Specifications</p>  <p>PS2R-□ P.0329~P.0330</p>	<p>Feeding Screw Stages New Specifications</p>  <p>PS1M-□ P.0330~P.0331</p>
<p>Feeding Screw Stage New Specifications X-axis</p>  <p>PS2M-□-25 P.0331</p>	<p>Miniature Actuators New Specifications X-axis</p>  <p>GACT-F(S)N(P)-□ P.0333~P.0335</p>	

Positioning Stages-Technical Information

- ◆Application Examples : P.0337~P.0338

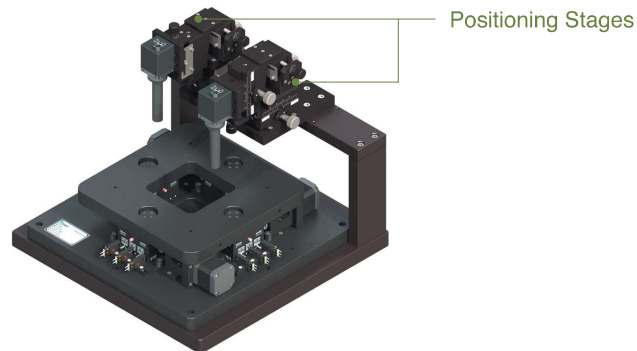

P

Manual Positioners

Manual Positioners-Product Information

- ◆Specifications Comparison Form : P.0003~P.0030

Manual Positioners-Technical Information

- ◆Reference Table of Basic Shaft Fitting / Bore Fitting : P.0341
- ◆Reference Table of Shaft Tolerance / Bore Tolerance : P.0342~P.0343
- ◆Hardness Reference Table : P.0344
- ◆Material Reference:Stainless Steel Series : P.0345
- ◆Components and Mechanical Properties of Stainless Steel : P.0346
- ◆Material Reference:Aluminum Alloy-Series : P.0347
- ◆Temper Designation of Aluminum Alloys : P.0348
- ◆Material Comparison : P.0349
- ◆Lubrication Description : P.0350
- ◆Cryogenic Process Description : P.0351
- ◆Prduct Alphabetical Index Page : P.0353~P.0354

Innovative Thinking · Rigorous Process · Reliable Quality

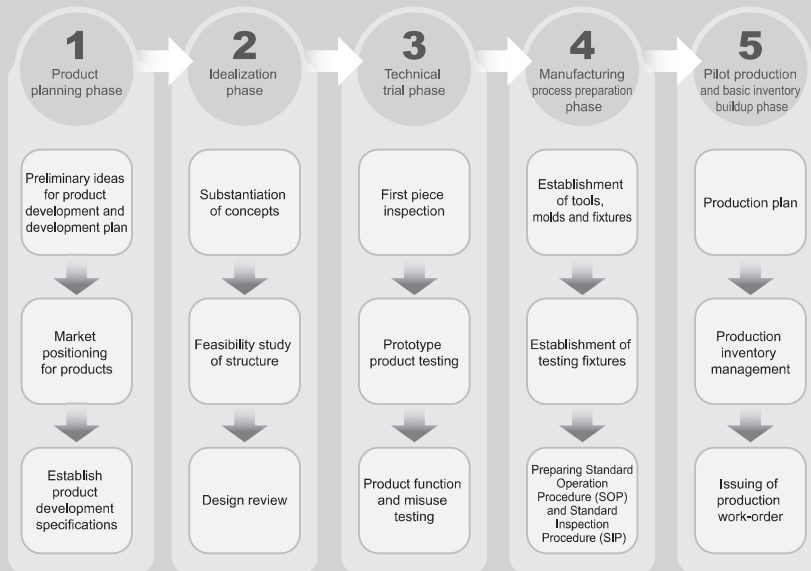

4

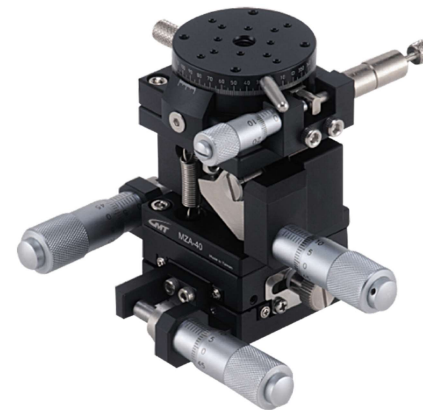

Positioning
Stages

Specification Comparison of the Mini-Stages

MX(Y)□-AC (AS) [Aluminum Alloy] - MICROMETER DESIGN			
Product Trait	Crossed roller guiding		
Pages	P.0047 ~ P.0051	P.0053 ~ P.0059	P.0061 ~ P.0065
Image			
Table Size [mm]	□20, □25, □30	□40, □50, □60, □70	□80, □100, □120
Travel Stroke [mm]	±3.2	±6.5	±12.5
Loading [kgf]	1~1.2	2 ~ 6, 1.8 ~ 6	10 ~ 20, 9.5 ~ 18.4
Weight [kg]	0.03~0.045, 0.06~0.09	0.14 ~ 0.44, 0.3 ~ 0.88	0.5 ~ 1.6, 1 ~ 3.2

P.0047
~
P.0065

MX(Y)L□-AC (AS) [Thin Aluminum Alloy] - Micrometer Design		
Product Trait	Crossed roller guiding	
Pages	P.0075 ~ P.0079	P.0081 ~ P.0083
Image		
Table Size [mm]	□30, □40, □60	□90, □125
Travel Stroke [mm]	±3.2 [□30], ±6.5 [□40, □60]	±7.5, ±12.5
Loading [kgf]	1 ~ 5, 1 ~ 5	8, 15
Weight [kg]	0.04 ~ 0.3, 0.08 ~ 0.5	0.45 ~ 1.1, 0.85 ~ 2

P.0075
~
P.0083

MLZ□-ASZ [Aluminum Alloy] - Micrometer Design				
Product Trait	Crossed roller guiding			
Pages	P.0085			
Image				
Table Size [mm]	□30, □40, □60, □90			
Travel Stroke [mm]	±3.2 [□30]	±6.5 [□40, □60]	±7.5 [□90]	
Loading [kgf]	1.5	1.5, 2	3	
Weight [kg]	0.1	0.21, 0.52	0.91	

P.0085

MZL □-ACR (As), SCR, (SS) [Aluminum Alloy], [Stainless Steel] - Micrometer Design		
Product Trait	Crossed roller guiding / Linear ball guiding	
Pages	P.0067 ~ P.0069	P.0135 ~ P.0137
Image		
Table Size [mm]	□25, □40, □60, □80	
Travel Stroke [mm]	±3.2 [□25], ±6.5 [□40, □60], ±12.5 [□80]	
Loading [kgf]	0.5, 1, 2, 5, 1 [□25], 5 [□40, □60, □80]	
Weight [kg]	0.06, 0.2, 0.45, 0.8, [0.23, 0.09], 0.32, 0.58, 1.2	

P.0067
~
P.0069

P.0135
~
P.0137

MYW □ - AS (AC), SS (SC) Series [Super Thin Aluminum Alloy], [Super Thin Stainless Steel] - Micrometer Design	
Product Trait	Crossed roller guiding, Linear ball guiding
Pages	P.0087 ~ P.0089 P.0139 ~ P.0141
Image	
Table Size [mm]	□ 40, □ 60, □ 80, □ 100
Travel Stroke [mm]	±6.5 [□ 40, □ 60], ±12.5 [□ 80, □ 100]
Loading [kgf]	1 [□ 40], 3 [□ 60], 4 [□ 80, □ 100], 9, 19, 20, 25
Weight [kg]	0.2, 0.4, 0.7, 1.1, 0.34, 0.64, 1.32, 2

MX(Y)□-AC (AS) [Aluminum Alloy] - Feeding Screw Design			
Product Trait	Crossed roller guiding		
Pages	P.0091 ~ P.0093	P.0095 ~ P.0101	P.0103 ~ P.0107
Image			
Table Size [mm]	□ 25, □ 30	□ 40, □ 50, □ 60, □ 70	□ 80, □ 100, □ 120
Travel Stroke [mm]	±3.2	±6.5	±12.5
Loading [kgf]	1	2 ~ 6, 1.8 ~ 6	10 ~ 20, 9.5 ~ 18.4
Weight [kg]	0.04 ~ 0.045, 0.08 ~ 0.09	0.14 ~ 0.44, 0.3 ~ 0.88	0.5 ~ 1.6, 1 ~ 3.2



MX764 - AC - SHR [Aluminum Alloy] - Micrometer Design			
Product Trait	Crossed roller guiding		
Pages	P.0109 [X axis]		
Image			
Table Size [mm]	76×64		
Travel Stroke [mm]	Coarse : ±6.5	Medium : ±0.325	Fine : ±0.0325
Loading [kgf]	1.5		
Weight [kg]	0.6		

MPS Series [Prober Stage Series, XYZ-Axis]			
Product Trait	Crossed roller guiding		Linear ball guiding
Pages	P.0114	P.0115	P.0116
Image			
Table Size [mm]	□ 20	20*35	□ 40
Travel Stroke [mm]	±3	±5	±6.5
Loading [kgf]	1	1.5	4.5
Weight [kg]	0.11	0.21	0.99

MBZ [Aluminum Alloy] - Low Profile		
Product Trait	Crossed roller guiding	
Pages	P.0110	P.0111
Image		
Table Size [mm]	□ 20	□ 30
Travel Stroke [mm]	±3	±3.25
Loading [kgf]	1	1.5
Weight [kg]	0.08	0.18

MXTH80 - FCS [Carbon Steel] - Feeding Screw Type	
Product Trait	Crossed roller guiding
Pages	P.0117
Image	
Table Size [mm]	□ 80
Travel Stroke [mm]	±20
Loading [kgf]	40.5
Weight [kg]	1.9

MX(Y)-SC (SS) [Stainless Steel] - Micrometer Design			
Product Trait	Linear ball guiding		
Pages	P.0119 ~ P.0121	P.0123 ~ P.0129	P.0131 ~ P.0133
Image			
Table Size [mm]	□ 25, □ 30	□ 40, □ 50, □ 60, □ 70	□ 80, □ 100
Travel Stroke [mm]	±3.2	±6.5	±12.5
Loading [kgf]	4 ~ 6, 3.9 ~ 5.9	10 ~ 23, 9.7 ~ 22.4	27 ~ 35, 26.1 ~ 33.6
Weight [kg]	0.07 ~ 0.08, 0.14 ~ 1.9	0.23 ~ 0.58, 0.46 ~ 1.16	0.9 ~ 1.33, 1.8 ~ 2.66

MYCP □ - A [Aluminum Alloy, XY-Axis] - Micrometer Design		
Product trait	Crossed roller guiding	
Pages	P.0112	P.0113
Image		
Table Size [mm]	□ 40	□ 60
Travel Stroke [mm]	±6.5	
Loading [kgf]	1.8	4.5
Weight [kg]	0.28	0.5

MX(Y)-SC(SS) [Stainless Steel] - Feeding Screw Type			
Product Trait	Linear ball guiding		
Pages	P.0145 ~ P.0147	P.0149 ~ P.0155	P.0157 ~ P.0159
Image			
Table Size [mm]	□ 25, □ 30	□ 40, □ 50, □ 60, □ 70	□ 80, □ 100
Travel Stroke [mm]	±3.2	±6.5	±12.5
Loading [kgf]	4 ~ 6, 3.9 ~ 5.9	10 ~ 23, 9.7 ~ 22.4	27 ~ 35, 26.1 ~ 33.6
Weight [kg]	0.07 ~ 0.95, 0.14 ~ 1.9	0.23 ~ 0.58, 0.46 ~ 1.16	0.9 ~ 1.33, 1.8 ~ 2.66

MXZ □, MXYZ □ - A, (S) [Aluminum Alloy], [Stainless Steel] - Micrometer Design		
Product Trait	Crossed roller guiding, Linear ball guiding	
Pages	P.0071 ~ P.0072	P.0143 ~ P.0144
Image		
Table Size [mm]	□ 25, □ 30, □ 40, □ 50, □ 60, □ 70, □ 80, □ 100. 《□ 120 Aluminum alloy》	
Loading [kgf]	□ 25 ~ □ 50 = 1, □ 60, □ 70 = 2 □ 80 ~ □ 120 = 5	□ 25 = 1, □ 30 ~ □ 100 = 5
Stroke and weight [kg] please refer to the product page		

MXYZA, MXYZWA, MXYR, MXYZAR, MXYWR, MXYZWAR [Aluminum Alloy] - Micrometer Design		
Product Trait	Multi-axis stage	
Pages	P.0073	P.0074
Image		
Table Size [mm]	Please refer to the product page	
Loading [kgf]	Please refer to the product page	
Stroke and weight [kg] please refer to the product page		





MX □ L - SS [Stainless Steel] - Feeding Screw Type	
Product Trait	Linear ball guiding
Pages	P.0161
Image	
Table Size [mm]	60×120
Travel Stroke [mm]	±12.5
Loading [kgf]	16
Weight [kg]	0.76

MC1A - □, MC2A - □, MC4A - □ Series [Body Material : Brass Alloy]			
Product Trait	Dovetail feeding screw type		
Pages	P.0200	P.0201	P.0202
Image			
Table Size [mm]	□ 25, □ 40, □ 60		
Travel Stroke [mm]	±3, ±7, ±9		
Loading [kgf]	3, 3, 4	2.9, 2.8, 3.4	1, 1, 2
Weight [kg]	0.07, 0.19, 0.47	0.15, 0.38, 1.2	0.09, 0.26, 0.75



MC1A - A □, MC1A - □ L, MC1A - □ KMR Series [Aluminum Alloy ; Lead : 4.2mm]		
Product Trait	Dovetail groove feeding screw thin type	Dovetail groove feeding screw type
Pages	P.0203	P.0206 P.0213
Image		
Table Size [mm]	□ 40, □ 60	40×60, 40×90 40×80
Travel Stroke [mm]	±11, ±21	±21, ±35 ±30
Loading [kgf]	2, 3	3, 3 4
Weight [kg]	0.10, 0.19	0.14, 0.19 0.31



MC4A - A □, MC4A - □ S Series [Aluminum Alloy ; Lead : 4.2 mm]		
Product Trait	Dovetail groove feeding screw type	
Pages	P.0204 [Z-axis thin type]	P.0210 [Z-axis]
Image		
Table Size [mm]	□ 60	40×90
Travel Stroke [mm]	±21	±35
Loading [kgf]	2.1	2
Weight [kg]	0.42	0.46



MC1 (2) A - □ CL, MC1 (4) - □ Series [Aluminum Alloy ; Lead : 0.5 mm]			
Product Trait	Dovetail groove feeding screw type		
Pages	P.0205 [X-axis, XY-axis]		P.0212 [X-axis, Z-axis]
Image			
Table Size [mm]	□ 60		□ 40
Travel Stroke [mm]	±9		±7
Loading [kgf]	4	3.4	3 2.1
Weight [kg]	0.47	0.98	0.2 0.28



MC1A - □L, MC1A - □C, MC1A - □S, MC2A - □S [Aluminum Alloy : Lead : 4.2 mm]							
Product Trait	Dovetail groove feeding screw type						
Pages	P.0206 [X-axis, T=18]		P.0207 [X-axis, T=26]		P.0208 [X-axis, T=26]		P.0209 [XY-axis]
Image							
Table Size [mm]	40×60	40×90	40×60	40×60	40×90	40×60	40×90
Travel Stroke [mm]	±21	±35	±21	±21	±35	±21	±35
Loading [kgf]	3		4, 2		4, 2		3.8, 3.72
Weight [kg]	0.14	0.19	0.19	0.19	0.29	0.43	0.62



MC1A - 425 Series [Aluminum Alloy : Lead : 4.2 mm]	
Product Trait	Dovetail groove feeding screw type
Pages	P.0211
Image	
Table Size [mm]	25×40
Travel Stroke [mm]	±12
Loading [kgf]	3, 1.5
Weight [kg]	0.09



MC1B - □, MC2B - □, MC4B - □ Series [Aluminum Alloy]			
Product Trait	Dovetail groove Rack and Pinion Type		
Pages	P.0215	P.0216	P.0217
Image			
Table Size [mm]	24.8×42, 40×60, 40×90, 40×140		
Travel Stroke [mm]	±12, ±21, ±35, ±60		
Loading [kgf]	3, 4, 4, 4	2.5, 3.5, 3.5, 3.5	1.5, 2, 2, 2
Weight [kg]	0.17, 0.29, 0.40, 0.56,	0.29, 0.51, 0.73, 1.08	0.17, 0.33, 0.45, 0.68

MC1C - □, MC3C - □ Series [Aluminum Alloy]		
Product Trait	Dovetail groove Rack and Pinion Type	
Pages	P.0219 ~ P.0220	P.0223
Image		
Table Size [mm]	50, 70, 100, 150, 200, 250	50, 70, 100, 150, 200, 250, 300
Travel Stroke [mm]	±15, ±25, ±40, ±65, ±90, ±115	±15, 25, ±40, ±65, ±90, ±115, ±140
Loading [kgf]	3	1.5
Weight [kg]	0.12, 0.12, 0.14, 0.17, 0.21, 0.36	0.12, 0.135, 0.16, 0.215, 0.3, 0.36, 0.41

MC1C - □ - 2, MC3C - □ - 2, MC3C - □ - 3 [Aluminum Alloy]							
Product Trait	Dovetail groove Rack and Pinion Type [Double blocks / Triple blocks]						
Pages	P.0221		P.0222		P.0224		P.0225
Image							
Table Size [mm]	25×150	25×200	25×300	150(high)	200(high)	300(high)	300(high)
Travel Stroke [mm]	±20	±37	±70	±20	±37	±70	±43
Loading [kgf]	3			3	1.5		1.5
Weight [kg]	0.24	0.28	0.35	0.27	0.3	0.48	0.55

MC1D - □, MC2D - □, MC4D - □ Series [Aluminum Alloy]			
Product Trait	Dovetail groove Rack and Pinion Type		
Pages	P.0226	P.0227	P.0228
Image			
Table Size [mm]	□25 [Brass alloy], □40, □60		
Travel Stroke [mm]	±5, ±10, ±20		
Loading [kgf]	3, 3, 4	2.9, 2.8, 3.0	0.7, 1.5, 2
Weight [kg]	0.09, 0.21, 0.64	0.18, 0.37, 1.19	0.11, 0.23, 0.6

MC1D - 40L, MC2DA - 48NH, MC1BL - 60 [Aluminum Alloy]			
Product Trait	Dovetail groove Rack and Pinion Type		
Pages	P.0229	P.0230	P.0233
Image			
Table Size [mm]	□40	Upper : 40×80 Lower : 40×80	40×60
Travel Stroke [mm]	±10	±35, ±30	±21
Loading [kgf]	2	3	3
Weight [kg]	0.25	0.6	0.3

MC3B - □, MC5B - □ [Aluminum Alloy], [Brass Alloy]		
Product Trait	Dovetail groove Rack and Pinion Type	
Pages	P.0231	P.0232
Image		
Table Size [mm]	□25 [Brass alloy], □40 [Brass alloy], □60	□25 [Brass alloy], □40 [Brass alloy], □60
Travel Stroke [mm]	±2.5, ±5, ±10	X = ±5, ±7, ±10, Z = +10, +10, +25
Loading [kgf]	0.7, 1, 1.5	1
Weight [kg]	0.08, 0.12, 0.47	0.17, 0.51, 0.62

MCS, MCD, MCV [None : Single Knob, W : Dual Knobs] [None : Z↑, L : Z↑Only] [Aluminum Alloy]										
Product Trait	Dovetail Rack and Pinion Type [Body weight = single knob type]									
Pages	P.0235 ~ P.0236		P.0237 ~ P.0238		P.0239 ~ P.0240		P.0241 ~ P.0242			
Image	◎/X	☆/X	◎/XY	☆/XY	◎/Z	☆/Z	◎△/Z	☆△/Z		
Table Size [mm]	[44 = 40×40, 46 = 40×60] =◎, [49 = 40×90, 41 = 40×140] =☆									
Travel Stroke [mm]	[±10, ±15] =◎, [±30, ±50] =☆, Z-axis with upper stroke direction only [+] = △									
Loading [kgf]	4		3.5		2		2			
Weight [kg]	0.24, 0.31	0.4, 0.55	0.41, 0.54	0.72, 1.07	0.26, 0.36	0.47, 0.67	0.23, 0.33	0.45, 0.63		

MCM, MCT - □ [None : Single Knob, W : Dual Knobs] [None : Z↑, L : Z↑Only] [Aluminum Alloy]											
Product Trait	Dovetail Rack and Pinion Type [Body weight = single knob type]										
Pages	P.0243 ~ P.0244		P.0245 ~ P.0246		P.0247 ~ P.0248		P.0249 ~ P.0250				
Image	◎/X+Z	☆/X+Z	◎△/X+Z	☆△/X+Z	◎/XY+Z	☆/XY+Z	◎△/XY+Z	☆△/XY+Z			
Table Size [mm]	[44 = 40×40, 46 = 40×60] =◎, [49 = 40×90, 41 = 40×140] =☆										
Travel Stroke [mm]	[±10, ±15] =◎, [±30, ±50] =☆, Z-axis with upper stroke direction only [+] = △										
Loading [kgf]	2										
Weight [kg]	0.5, 0.67	0.87, 1.23	0.47, 0.64	0.85, 1.18	0.67, 0.9	1.2, 1.74	0.64, 0.87	1.17, 1.7			

MC□D - 2550, MC□E - □ [Brass Alloy]				
Product Trait	Dovetail groove Rack and Pinion Type / Hexagon wrench type			
Pages	P.0251		P.0253	
Image		1 = X-axis 4 = Z-axis 6 = XY + Z-axis	2 = XY-axis 5 = X + Y-axis	
Table Size [mm]	25×50		□25, □40, □60	
Travel Stroke [mm]	±10		±3, ±5, ±7	
Loading [kgf]	X, XY = 8 ; Z, X + Z, XY + Z = 1		3 [2.9] 《1》, 3 [2.8] 《1》, 4 [3.4] 《2》	
Weight [kg]	0.22, 0.44, 0.3, 0.52, 0.75		0.07 [0.15] 《0.08》, 0.19 [0.38] 《0.27》, 0.6 [1.2] 《0.65》	



MC6E - 25 Series [Brass Alloy]	
Product Trait	Dovetail groove Rack and Pinion Type
Pages	P.0257 [XYZ-axis]
Image	
Table Size [mm]	25×25
Travel Stroke [mm]	±3
Loading [kgf]	1.9
Weight [kg]	0.22



MC1G - 525C (F), MC1G - 535C (F), MC7G - 4050C (F) [Aluminum Alloy]			
Product Trait	Dovetail groove feeding screw type [PITCH = C : 0.5, F : 0.25]		
Pages	P.0258	P.0259	P.0260
Image			
Table Size [mm]	□ 50	□ 50	40×50
Travel Stroke [mm]	±11	±16	Upper(Fine) : ±17.5 Lower(Coarse) : ±30
Loading [kgf]	5	5	4
Weight [kg]	0.27	0.29	0.5



MC1G - 35LG, MC6G - 35LG [Aluminum Alloy]			
Product Trait	Dovetail groove Rack and Pinion Type (Adjustable for CCD)		
Pages	P.0261	P.0262	
Image			
Table Size [mm]	24.5×35	—	
Travel Stroke [mm]	±10	20 [X-axis]	30 [Y-axis] 60 [Z-axis]
Loading [kgf]	3	2	
Weight [kg]	0.25	0.81	



MC1F - 40 [Aluminum Alloy]	
Product Trait	Dovetail groove Positioning Stage
Pages	P.0263
Image	
Table Size [mm]	□ 40
Travel Stroke [mm]	±10
Loading [kgf]	3
Weight [kg]	0.17



MNG□E - □CL, MNE□E - □ [Aluminum Alloy]		
Product Trait	Simplified guiding (mini type) - Feeding screw / Threading screw	
Pages	P.0163 ~ P.0165	P.0167 ~ P.0169
Image		
Table Size [mm]	□20, □25, □40, □60	
Travel Stroke [mm]	[□20, □25] = ±5, [□40, □60] = ±7.5	[□20, □25] = ±7, ±9, ±13
Loading [kgf]	[□20, □25] = 0.2, [□40, □60] = 1.5	[□20, □25] = 1.9, [□40, □60] = 3.7
Weight [kg]	0.038 《as left》, 0.055 《as left》, 0.104 《0.202》, 0.193 《0.358》	0.1, 0.13, 0.27, 0.48



		MNE1E - □, MN□A - □ [Aluminum Alloy]	
Product Trait	Simplified guiding (mini type) - Selectable screw / Single spring		
Pages	P.0171		P.0173
Image	 [] = Shared value		 [] = dual axis
Table Size [mm]	40×40, 40×25, [60×60, 60×40]		12×13, 15×17, [12×13, 15×17]
Travel Stroke [mm]	10 [15], 25 [30], 40 [50], 60 [70]		±1.7, ±5, [±1.7, ±5]
Loading [kgf]	4 [8], 3.5 [7], 4 [8], 3.5 [7]		0.5, 1, [0.5, 1]
Weight [kg]	Based on the screw type selected		0.005, 0.02, [0.01, 0.04]



		MZA - □, MZA□ - 5060 [Aluminum Alloy]	
Product Trait	Crossed roller guiding		
Pages	P.0175		P.0177 ~ P.0178
Image			 types specifications
Table Size [mm]	□ 25, □ 40, □ 40H, □ 60L, □ 60, □ 80		50×64
Travel Stroke [mm]	±2, ±3, ±3, ±3, ±5, ±5		5
Loading [kgf]	1, 1, 2, 2, 4, 3		MZA1 = 7, MZA2 = 8, MZA3 = 10
Weight [kg]	0.06, 0.2, 0.2, 0.3, 0.6, 1		MZA1 = 0.62, MZA2 = 0.63, MZA3 = 0.72



		MZP - □ [Aluminum Alloy]	
Product Trait	Rapidly Z-axis lifting stage		
Pages	P.0179		
Image			
Table Size [mm]	80×120, 120×180		
Travel Stroke [mm]	40, 70		
Loading [kgf]	7, 10		
Weight [kg]	1.25, 3.5		

		MR □ - AR (Standard), MRL □ - AR (Thin Type), MRE □ - A [Aluminum Alloy]		
Product Trait	Rotary stage - [Precise - Standard type, Thin type], [Economy type]			
Pages	P.0181		P.0183	P.0186 ~ P.0187
Image				
Table Size [mm]	Ø38, Ø60, Ø85, Ø110		Ø30, Ø40, Ø60, Ø90, Ø125	Ø40, Ø60, Ø85, Ø100
Travel Stroke [°]	Cursor360° [Fine : inferto the page]		Cursor360° [Fine±5°]	
Loading [kgf]	1, 3, 4, 5		1, 1.5, 3, 3, 3	
Weight [kg]	0.09, 0.28, 0.48, 0.75		0.1, 0.1, 0.2, 0.5, 0.9	
			0.14, 0.2, 0.4, 0.66	

		MR50 - AR - 48 [Aluminum Alloy], MR85 - S [Stainless Steel]	
Product Trait	Rotary stage - Precise type, Heavy loading type		
Pages	P.0185		
Image			
Table Size [mm]	Ø50		Ø85
Travel Stroke [°]	±5.5°		Cursor360° [Fine±5.5°]
Loading [kgf]	1.8		6
Weight [kg]	0.26		1

		MMT - □, MMS - □ [Carbon Steel]	
Product Trait	Magnetic base - Thin type, Standard type		
Pages	P.0188		P.0189
Image			
Table Size [mm]	12×38×51, 12×52×63, 12×66×80		20×□45, 20×□65, 20×□90, 20×□125
Travel Stroke [mm]	0.015, 0.02, 0.02		0.015, 0.02, 0.02, 0.02
Magnetic [kgf]	1, 3.3, 3.8		17, 20, 25, 70
Weight [kg]	0.3, 0.6, 1.2		0.3, 0.6, 1.2, 2.8

		MTB - □, MTS - □ [Aluminum Alloy]	
Product Trait	Tilt stage - Feeding screw type, Thumbscrew type		
Pages	P.0191		P.0193
Image			
Table Size [mm]	□ 40, □ 60, □ 80		□ 30, □ 60, □ 90, □ 125
Travel Stroke [mm]	±2°		
Loading [kgf]	2, 4, 5		2, 4, 5, 5
Weight [kg]	0.03, 0.15, 0.4		0.03, 0.15, 0.4, 1

		MXG □ - □CS, MYG □ - □CS [Brass Alloy]	
Product Trait	Dovetail - α-axis, αβ-axis Goniometer stage [Transmission : Worm + Worm gear]		
Pages	P.0265 ~ P.0267 (□ 40), P.0269 (□ 50), P.0265 ~ P.0267 (□ 60)		
Image			
Table Size [mm]	□ 40, □ 50, □ 60		
Travel Stroke [°]	±8° ~ ±25°		Upper axis : ±10° ~ ±25°; Lower axis ±8° ~ ±20°
Loading [kgf]	3 ~ 6		2.8 ~ 5.4
Weight [kg]	0.18 ~ 0.55		0.42 ~ 1.1

MXG9 - 118CS [Brass Alloy]	
Product Trait	Dovetail - Goniometer stage [Transmission : Worm + Worm gear]
Pages	P.0271 [α axis]
Image	
Table Size [mm]	□ 90
Travel Stroke [°]	±12°
Loading [kgf]	7.5
Weight [kg]	0.33

MXG □ - □CE, MYG □ - □CE [Brass Alloy]	
Product Trait	Dovetail - α -axis, $\alpha\beta$ -axis Goniometer stage [Transmission : Threading screw]
Pages	P.0273 (□ 30), P.0275 (□ 40), P.0277 (□ 60)
Image	
Table Size [mm]	□ 30, □ 40, □ 60
Travel Stroke [°]	±5° ~ ±8° Upper axis : ±6° ~ ±8° ; Lower axis : ±5° ~ ±6°
Loading [kgf]	1.5, 3, 5
Weight [kg]	0.1, 0.3, 0.7 0.2, 0.6, 1.4

MXG4 - □ VM, MXG5 - □ VM, MXG6 - □ VM Series [Aluminum Alloy]	
Product Trait	Dovetail - Crossed roller Goniometer stage [Transmission : Micrometer type]
Pages	P.0279 [α -axis] P.0281 [α -axis]
Image	
Table Size [mm]	□ 40 □ 50 □ 60
Travel Stroke [°]	±7°/40 ±4°/60 ±4°/80 ±3°/50 ±4°/50 ±3°/75 ±3°/100
Loading [kgf]	3 4.5
Weight [kg]	0.15 0.2 0.33

MCV100 - AS [Aluminum Alloy]	
Product Trait	Clamping fixture (Vice)
Pages	P.0283
Image	
Table Size [mm]	100×94
Travel Stroke [mm]	0 ~ 49
Loading [kgf]	20
Weight [kg]	0.55



MC1B - 60F	
Product Trait	Dovetail Rack and Pinion Type
Pages	P.0218
Image	
Table Size [mm]	40×60
Travel Stroke [°]	±12°
Loading [kgf]	20
Weight [kg]	1.6

Manual Fiber Positioning



M3E - 2000S - L(R), M5E - 2000B - L(R), M6E - 2200B - L(R)				
Product Trait	XYZ, XYZ θ y θ y, XYZ θ x θ y θ z - Axis			
Pages	P.0285 P.0289 P.0293			
Image				
Cursory Tuning Travel Stroke	X	±6.5 mm	±6.5 mm	±6.5 mm
	Y	±6.5 mm	±6.5 mm	±6.5 mm
	Z	±6.5 mm	±6.5 mm	±6.5 mm
	θ x		±3°	±3°
	θ y		±3°	±3°
	θ z			±4°
Fine Tuning Travel Stroke	X	±0.3 mm	±0.3 mm	±0.3 mm
	Y	±0.3 mm	±0.3 mm	±0.3 mm
	Z	±0.3 mm	±0.3 mm	±0.3 mm
	θ x		±3°	±3°
	θ y		±3°	±3°
	θ z			±4°
Cursory Tuning Resolution	X	±10 μ m	±10 μ m	±10 μ m
	Y	±10 μ m	±10 μ m	±10 μ m
	Z	±10 μ m	±10 μ m	±10 μ m
	θ x		≒29.3"/div.	≒29.3"/div.
	θ y		≒27.8"/div.	≒27.8"/div.
	θ z			≒33"/div.
Fine Tuning Resolution	X	±0.5 μ m	±0.5 μ m	±0.5 μ m
	Y	±0.5 μ m	±0.5 μ m	±0.5 μ m
	Z	±0.5 μ m	±0.5 μ m	±0.5 μ m
	θ x		≒29.3"/div.	≒29.3"/div.
	θ y		≒27.8"/div.	≒27.8"/div.
	θ z			≒33"/div.

Product Trait		M5F - 460A561 - L(R)	
Pages		XYZ, $\theta_x\theta_y$ - Axis P.0297	
Image			
Travel Stroke	X	0.5 inch(12.7 mm)	
	Y	0.5 inch(12.7 mm)	
	Z	0.5 inch(12.7 mm)	
	θ_x	$\pm 5^\circ$	
	θ_y	$\pm 5^\circ$	
Material	X	Aluminum alloy	
	Y	Aluminum alloy	
	Z	Aluminum alloy	
	θ_x	Stainless Steel	
	θ_y	Stainless Steel	
Allowable Loading		67 N	

Product Trait		MTS - 561 - L(R)	
Pages		θ_x, θ_y - Axis Tilt Stage P.0301	
Image			
Travel Stroke	θ_x	$\pm 5^\circ$	
	θ_y	$\pm 5^\circ$	
Sensitivity		Each circular motion equals 5arc-seconds	
Material		Stainless Steel	
Allowable Loading		22 N	

Product Trait		MXY - 460AL(R), MXYZ - 460AL(R)	
Pages		XY-Axis crossed roller guiding type, XYZ-Axis crossed roller guiding type P.0305 P.0309	
Image		 	
Travel Stroke	X	0.5 inch(12.7 mm)	
	Y	0.5 inch(12.7 mm)	
	Z	0.5 inch(12.7 mm)	
Resolution		10 μ m	
Material		Aluminum alloy	
Allowable Loading		67 N	

Optical Adjuster

Product Trait		MOVm - S□	
Pages		Vertical mounting P.0313	
Image		 	
Optics Diameter		1"	2"
Tilt Range	X	$\pm 2.5^\circ$	
	Y	$\pm 2.5^\circ$	
Sensitivity		2 arcsec	
Material		Stainless Steel	
Allowable Loading		0.25 Kg	0.6 Kg

Micrometer

Product Trait		MHGS - □□ - □				
Pages		Fronttip -Flate, Round & Installation-Lock screw, Set screw P.0317 ~ P.0325				
Image						
Measurement range		0~6.5 mm	0~13 mm	0~15 mm	0~25 mm	0~50 mm
Accuracy		0.005 mm				
Minimum resolution		0.01 mm				
Micrometer tolerance		$\pm 2 \mu$ m				
Vernier		Positive scale				

Feeding Screw Stages

Product Trait		PS□□ - □		
Pages		Precision Screw P.0329 ~ P.0331		
Image				
Travel stroke range		0~7mm	0~13 mm	0~25 mm
Accuracy		0.03 mm		
Minimum reading		0.01 mm, Vernier		
Knob type		Pattern, Hexagon socket		

Miniature Actuators

		GACT - □□ - □		
P.0333	Product Trait	Miniature actuators		
P.0335	Pages	P.0333 ~ P.0335		
	Image			
	Measuring Range [mm]	0~6.5 mm	0~13 mm	0~25 mm
	Transmission	Precision thread M6x0.5P		
	Body Weight [kg]	0.129 Kg		
	Pilot Shape	F : Flat measuring surface / S : Spherical measuring surface		
	Installation	N : Locknuts / P : set screws		
	Scale Shape	N scale		
	Material / Color	Actuator : aluminum ally / black anodized		
	Dpi(Pulse) Full / Half [mm]	0.0025 0.00125		
	Veneered Positioning Accuracy [mm]	0.01		
	Repeat Positioning Accuracy [mm]	0.003		
	Allowable Load [N]	29.4 N		
	Maximum Speed [mm/sec]	2		
Motor	Motor Model / Shaft Numbers	2-phase stepping / 20□ dual extension shafts		
	Manufacturers	Orientalmotor / GMT		
	Model No.	CVK213BK / 2MS-N20D33A		
Connector	Actuator cable connector	15Pin Public-side connector D-SUB		

Positioning Stages

Characteristic of Different Guiding Type

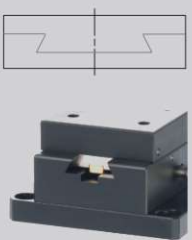
Slide Way	Structure	Characteristic
Crossed roller		The slide rail consists of two hardened V-grooves with fine ground surface and crossed roller bearings.
Linear ball		Slide way and body is in one unit, and Gothic arc-groove ground precisely to meet requirement of high parallelism and high flatness. Gothic arc-groove formed by dual arc-grooves individually on upper and lower rails of body. Ball moving in single groove is structured by 2 points – contact, and total 4 contact points in dual arc-groove to form strong rail construction. In case of rails of SUS-STAGE is to set ball assembly in arc-groove to save traditional adjustment and revision time. In addition, without adjustment screw would save accuracy problem and maintenance time caused by loosen screw, and cheaper as well.
Dovetail type		Dovetail plane-pinion and rack (Main material: Brass or aluminum alloy) GMT supplies proper models suitable to be equipped to various modules such as small, coarse or fine turn, larger size for installation etc. Driven-adjustment mode is rack and pinion. Apply to higher working frequency, requirement of faster movement and larger stroke. Screw-driven plane (main material: brass) Prepared by easy-carry standard and slide type fit for inner set mode. Driven adjustment mode is screw shaft mode. Apply to lower frequency, fine tuning environment.
XY Simplified stage		Round sticks on two sides are applied to support middle transmission construction: Feeding screw type To move stage table by push-and-press from screws, and to restrain gap produced by using springs tensile force. It's the type suitable for light loading and accuracy feeding application. Threading type The stage table is moved by thread which has been crossed through to the table. The stage table will be feed-movement in Z-axis application. The stage is suitable for heavier loading compared to feeding screw with spring transmission type.

Positioning Stages

Characteristic of Different Guiding Type

Application	Moving Accuracy	Load Capacity	Rigidity
This is suitable for precise movement device in high accuracy and high capacity, optical instruments in precise gauging and fine tuning, various machine tools, gauging instruments, precise positioning and quantitative movement...etc.	Excellent	Excellent	Excellent
Applied to precise positioning device in high accuracy and mid-capacity, product and design integrated system, optical experiment, precise transportation and fine tuning mechanism application.	Excellent	Good	Good
It is applied to optical instruments and equipments, sampler, detecting device, semi-conductor manufacturing equipment, test machine, microscope, transiting machine, machining center, medical instrument, printer and others.	Fair	Good	Excellent
The product is applied to fixture, camera, sensor, nozzle, and guiding groove of the conveyor, those equipments don't require high accuracy adjustment.	Fair	Fair	Fair

Outline

- Mini-Stage is applied for high precision or mid and heavy loading of various production machinery, testing device, precise positioning and quantitative movement.
- There're many types of mini-stages with single axis (X-axis); dual axes (XY-axis); Z-axis; θ -axis, α -axis... can be collocated as needed.





Characteristics

- Can be customized according to the requirements of precise fine tuning; positioning; quantitative movement and able to proceed mass feed of fine tuning.
- Coordinated customer's precise machinery of instrument and fixed in suitable position.
- Feeding mode diversification such as coarse moving handle/ micrometer head; feed screw, rack and pinion with scale and able to manage movement rate.
- The sets of mini stages, XY-axis, XYZ-axis, XZ-axis, and multi-axis modules are able to effectively reduce assembling process because of adjusting their vertical angle before shipping.

Standard Selection

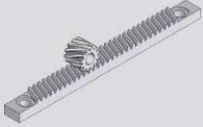
- GMT presents clearly with each kind of mini stages in accordance with different types of moving axis, minimum reading and loading capacity.
- Please coordinate with adjusting methods and refer below information to select the most suitable stages.
- Please refer to the feeding method provided to select the most suitable stages.

The Main Feeding Mode of Mini Stages

Main feeding mode	Characteristics	A circle movement of handle rotation	Applied for guiding device
 <p>Rack and Pinion</p>	<ul style="list-style-type: none"> ● Suitable for high speed mass feed. ● Not suitable for precise positioning. 	17~20 mm	<ul style="list-style-type: none"> ● Dovetail
 <p>Feeding Screw</p>	<ul style="list-style-type: none"> ● Use precise threadscrew pitch to proceed simple precise moving. 	0.25~1 mm	<ul style="list-style-type: none"> ● Dovetail ● Crossed roller ● Linear ball bearing
 <p>Micrometer Head</p>	<ul style="list-style-type: none"> ● Precise reading Unit: 0.01mm is suitable For precise tuning. 	0.5 mm	<ul style="list-style-type: none"> ● Dovetail ● Crossed roller ● Linear ball bearing
 <p>Rough Slightly Moving Micrometer Head</p>	<ul style="list-style-type: none"> ● Divided into rough moving (general feeding) and slight moving (micro feeding) use. ● It's a special feeding device and a bit costly. ● Differential motion Structure for slightly transmission. 	Coarse tuning : 0.5 mm Fine tuning : 0.025 mm	<ul style="list-style-type: none"> ● Linear ball bearing ● Crossed roller

Straightness (refer to JIS B 6191-1993)

In linear motion units, geometric straight line decides positions in order from datum point to same direction, differences between length variation in those positions and datum is as measured value. To connect datum and final testing post, the max. difference of geometric line is called "Straightness".

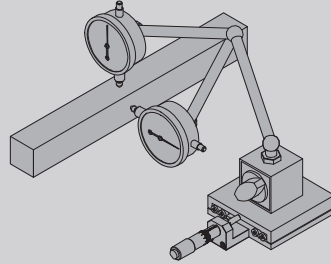

Yawing and Pitching (refer to JIS B 6191-1993)

Linear motion parts would occur slanting in Transmitting, and slanting proportion would cause deflection in linear transmission. Position is decided by same direction from datum point in order, and maximum angular gap measured from horizontal direction of each position corresponding to the datum is called yawing (deviation). Same situation to have the maximum angular gap from vertical direction of each position corresponding to datum called pitching.

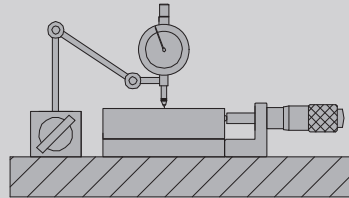

Parallelism (refer to JIS B6191-1993)

Parallelism of plane, and slanting proportion between parallel interval to mechanism parts, and degrees between center place of manual stage movement and base plate is called parallelism. Parallelism measurement is to fix micrometer on the plate, and operate manual stage with clamping device to measure the maximum of 4 corner errors.

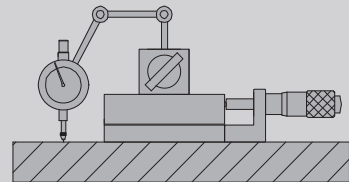

XY Vertical Value (refer to JIS B7440-1987)

Vertical value between 2 axes also for one line of geometric line in transmission datum and one in its corresponding right angle. In the other direction (Opposite), to take slanting proportion in linear transmission, reference point of X-axis stage, and geometric line of final tested position as datum axes. X-axis stage as for datum axis, maximum of parallel errors from its vertical geometric line in opposition to datum position of Y-axis stage to final tested position is called XY vertical value.

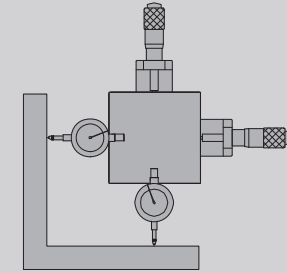

Concentricity (refer to JIS B 6191-1993, B6194-1997)

Difference of datum circle and geometric circle. All points in line in same plane of 2 concentric circles, radius difference of 2 concentric circles is in case of smallest radial interval difference. Opposite to geometric circle, measured difference is called concentricity. Fix rotating stage on the plate, and put micrometer around stage. Have it to rotate one circle (360°) to proceed measuring. Concentricity is half of top value shown in micrometer.

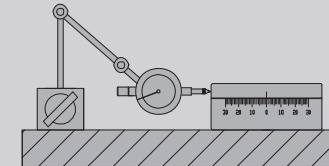

Plane travel Amplitude (refer to JIS B6191-1993)

Rotate as center of single axis, in the period of plane turning, max. slanting value of deviation of vertical plane to datum axis back to stage vertically is called plane travel amplitude. Take micrometer fixed on the plate to contact upper edge of rotating stage (rotating one circle 360), and proceed measuring. Top value shown in micrometer is called Plane-pulsating.

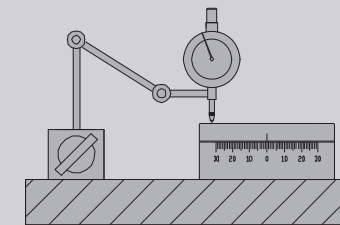

Inspection of Level Z axis (GMT specification)

The stage surface will be slanted caused by transmission components while the stage moves vertically. In order to check if the stage surface is remained in a level, GMT offers an inspection method which is to place 4 inspection meters on the ends of two diagonal lines according to the stage platform, then, check sum of plus and minus figures measured from 4 meters during movement, regard as the level variation of the stage vertical movement.

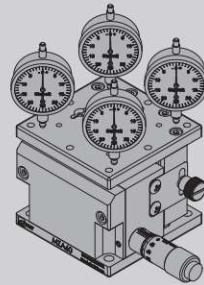

Precision of Rotation Center Height (GMT specification)

To use a specified inspection tool (meter) (The tool (meter) has been calibrated its circle center matched to the rotation circle center of goniometer stage) to check the tool (meter) indicator changes during repeated movement to examine the circle center accuracy.

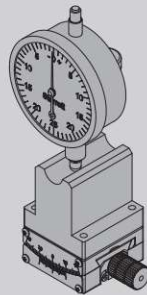

Vertical Z axis (GMT specification)

To check measured figures from the meter applied to the area between limited strokes during vertical movement.

The sum of plus and minus figures measured from the meter means the variation between the movement vertically with base surface.

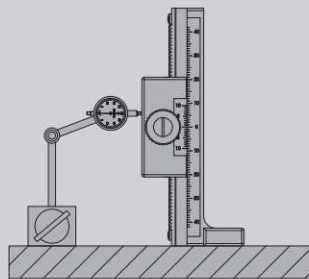

XY Simplified Stage (Feeding Screws)

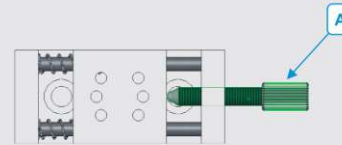

- Remove feeding screws (A)

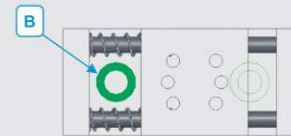

- To have B side fixed with a bolt.



- To have stage table slid to B side.
- To have C side bolt fixed.
- To lock up the feeding screws.

XY Simplified Stage (Threading Type)

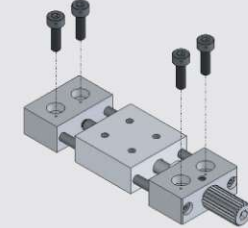

- The stage has been integrated counter bores on left and right sides for mounting.

Leavel Z Axis Stage

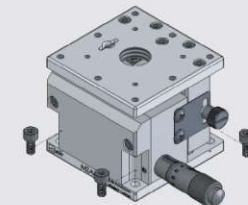

- There are 4 holes reserved for bolts Screw-in on 4 corners of the stage upper surface. It can be screwed-in by the hex-wrench without conflict.

Tilt Stage (Thumbscrew Type)

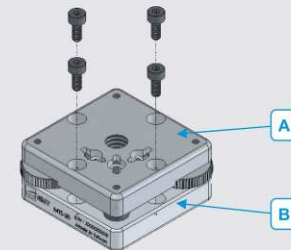

- The mounting holes on the upper plates (A) have been drilled through and counter bores on the lower plate, (B) such design offers an easier assembly to have bolts assembled from upper plate directly.

Tilt Stage (Feeding Screw Type)

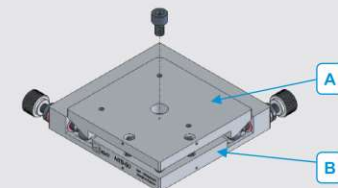

- The mounting holes on the upper plates (A) have been drilled through and counter bores on the low plate, (B) such design offers an easier assembly to have bolts assembled from upper plate directly.

Single Axis

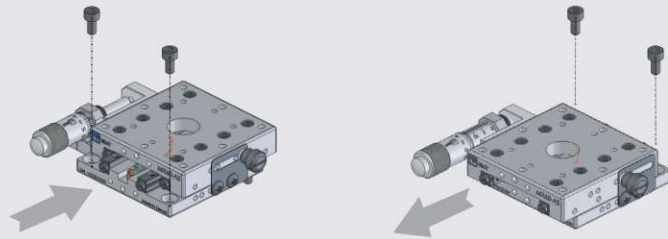

Move upper plate back and forth, and secure the screw on the base plate and work piece with tight confirmation.

Dual Axis

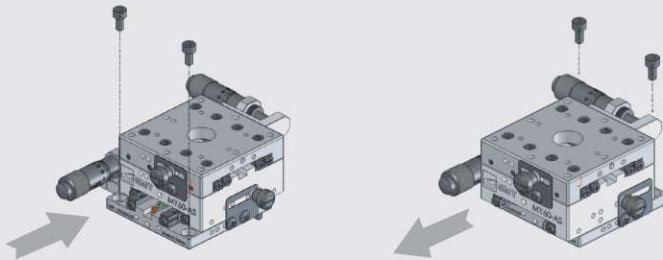

Screw security same as single axis.

θ Axis

- ◆ Move upper plate by rotating, and take the screw through it.
- ◆ Proceed taking screws through base plate with matched bores respectively.
- ◆ Lock the stage on the work piece with tight confirmation.

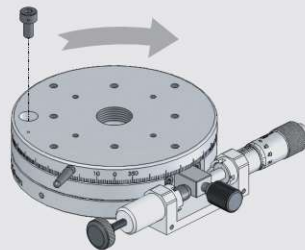

Goniometer Stage

Rotate knob clockwise to move plate to the other side. (Please operate after losing safety knob), to adjust locked screw into half-secured status. Next, rotate knob counterclockwise to move plate to the other side, and secure the screw on base plate and work piece with tight confirmation.

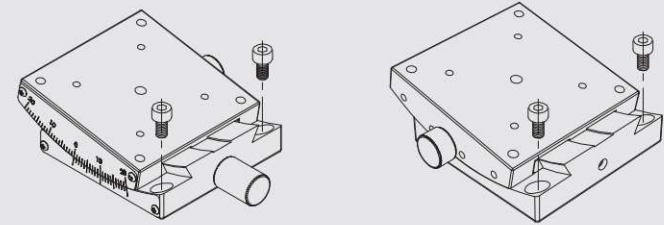

Other Stages

Consider easy installation fit for other devices, threaded holes pattern is made to meet requirement of securing from upper or lower direction, and this provides more options for installation.

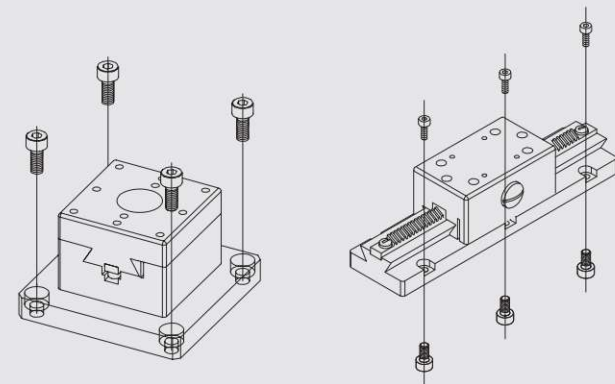

Axes Definition

Regarding definitions of moving and rotating axis, GMT defines as the diagram below.
X-axis, Y-axis are in parallel direction; Z-axis in vertical direction;
Rotating around X, Y, Z-axes are called α -axis, β -axis, θ -axis individually.

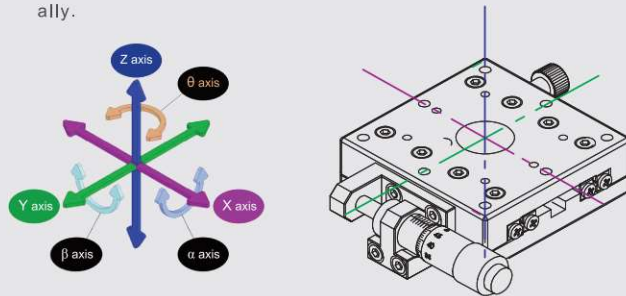

Temperature of Environment

Operating stages in regular range of temperatures as listed. Please contact GMT if products in wider temperature ranges required.

Stages classification	Working temperature
Stainless steel stage	-20°C ~120°C
Stainless steel slide	
Others	-20°C ~70°C

Volume-Loaded Limit Recommendation

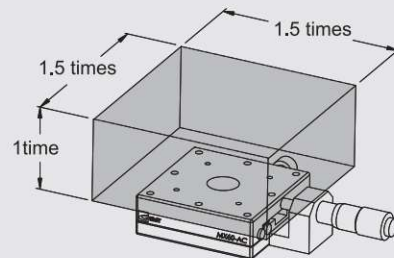

Basic Declaration

1. Diagrams of representative explanation in catalogs are sampled in GMT products series. Products compared to diagrammatic examples in same series may have some difference in shape due to different mechanism design and spec, but basic operation remark are all the same.
2. Photo images are for reference only. For application design, please download 2D drawing.

Notice

Please read operation principles before your use, this would have GMT product series performed for the best motion accuracy and usage life.

Operation Principles

1. GMT product series are all composed of parts in high accuracy, please avoid extreme environment such as high temperature, extreme low temperature, huge temperature variation, exposed to sun light, high humidity, high dust, high vibration, high shock and easy-dewed...etc.
2. To maintain motion accuracy and usage life of products in all series, please check allowable capacity of the product before operation. Do not overload out of rated capacity.
3. Besides allowable capacity limit, please avoid taking barycenter of loaded object out of the edge of the stage.
4. All kinds of rolling mechanisms set in the product need proper clean and lubricated maintenance in the period of operating, depending on operating conditions, and use appropriate lubricant.
5. All kinds of rolling mechanisms set in the product are adjusted and leveled by engineers before shipment, please do not try any adjustment if not have been trained or authorized.
6. Use right lock unit, tools and torque wrench while processing products in positioning security and connecting security.
7. For accessories of GMT product series or related information, GMT sales could offer best consultation. www.gmtlinear.com
8. GMT also provide custom-made service for special purpose application or other unique spec.

M Y 60 - A C - 1 5

Transmission Method	Axis Code	Table Size	Material	Selectable Spec		
				Transmission Positions	Guiding Rail	Transmission
M : Manual	X : Single axis	Various spec, based on the chosen axis code.	A : Aluminum Alloy	S : Side, Forehand	1 : Cross Roller	3 : Cursory and fine micrometer (stage type of dual micrometer)
	Y : Dual axis		S : Stainless Steel	SR : Side, backhand	2 : Linear Ball	4 : Worm+Wormgeal
	Z : Integration of plate and bracket		SZ : Side, Forehand + micrometer upward	3 : Rotary copper elements	4 : Cross Roller Bearing	5 : Standard micrometer
	R : θ axis		SZR : Side, backhand + micrometer upward	4 : Cross Roller Bearing	5 : Groove Ball Bearing	6 : Cursory and fine micrometer (stage type of two-stage single micrometer)
	XL : Thin type, single axis		C : Centre, Forehand	6 : Simplified guide	CSR : Central: cursory adjustment Lateral: fine adjustment	7 : Electronical Micrometer
	YL : Thin type, dual axis		CZ : Centre, backhand	8 : Feeding screw	L : Left	9 : Ball screw
	RL : Thin type, θ axis		CSR : Central: cursory adjustment Lateral: fine adjustment	R : Right	V : Vertically placed	
	LZ : Thin type, +L plate		L : Left	H : Horizontal placed		
	YW : Ultra thin type, dual axis		R : Right			
	ZL : Standard type, +L plate		V : Vertically placed			
	YP : Thin type, through hole, dual axis		H : Horizontal placed			

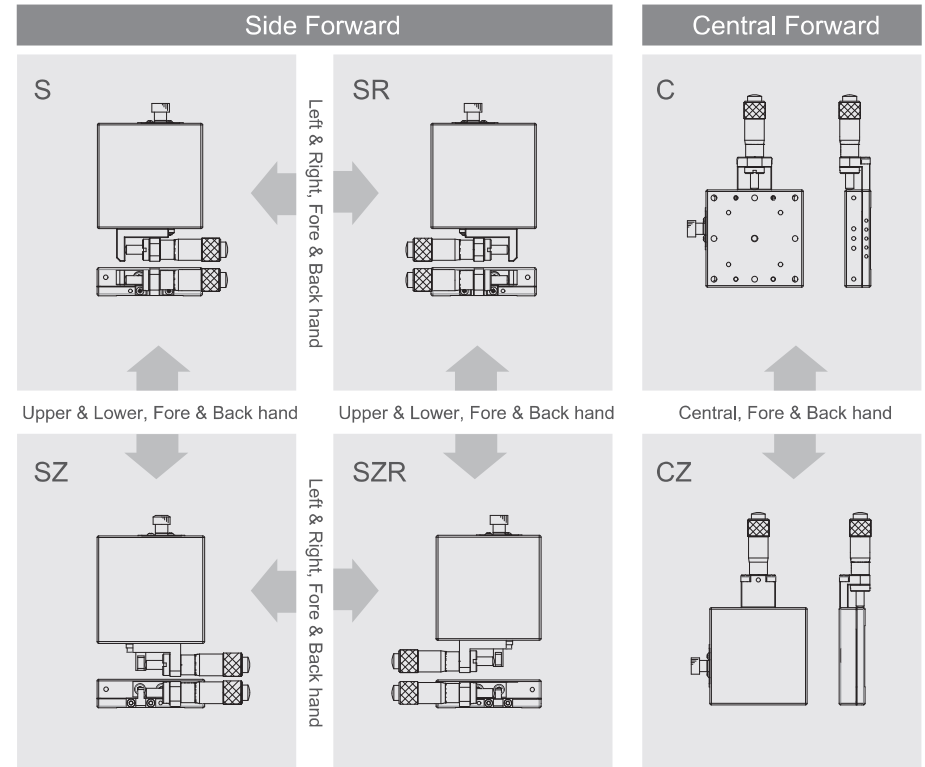

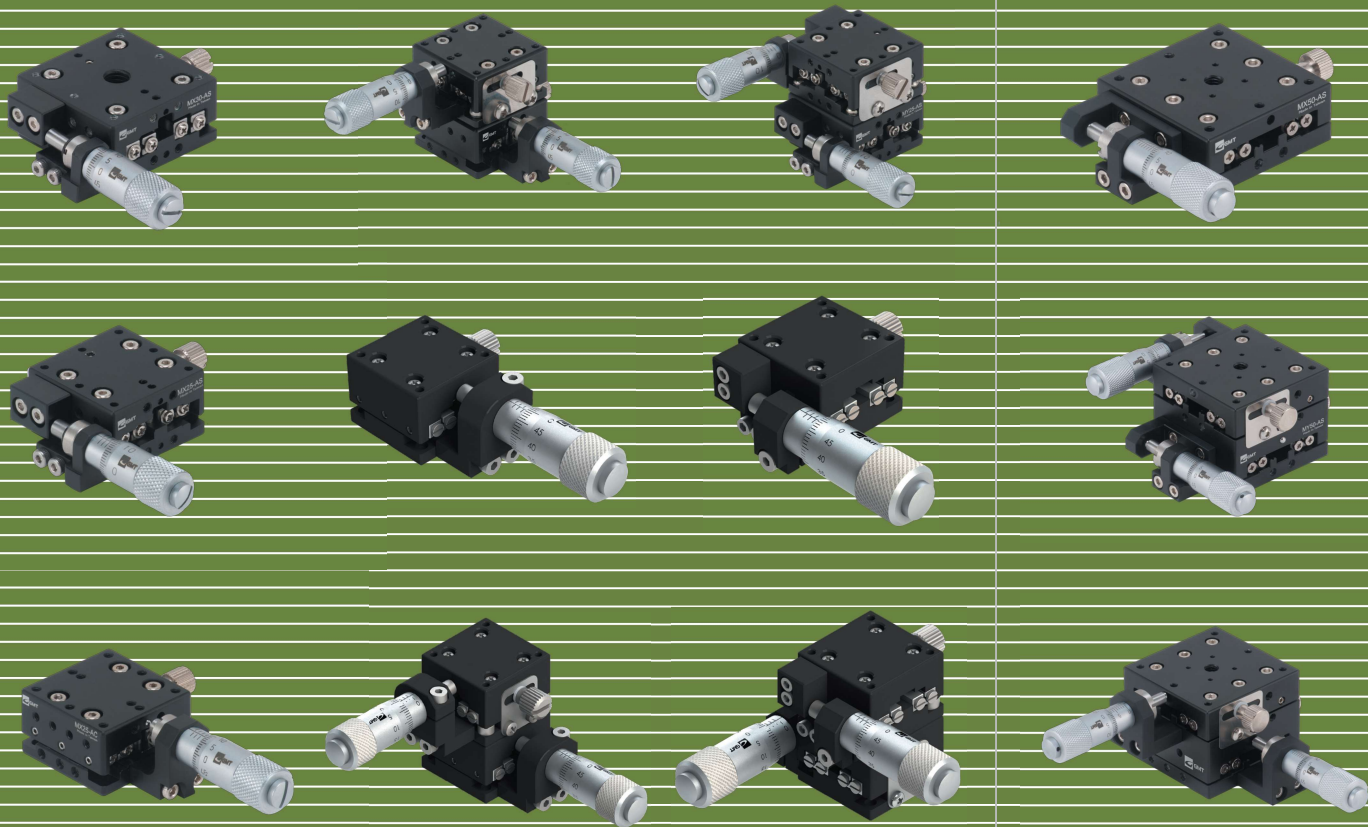

Product
Specification
**Positioning
Stages**

MX20-AC



MX20-AS



MY20-AC

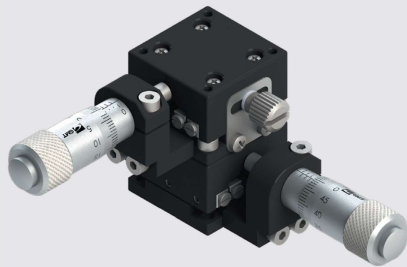

MY20-AS



Specification

Unit : mm

Model No.	Table Size	Axis	Feed Position	Travel Stroke	Micrometer Minimum Reading (μm)	Straightness Accuracy (μm)	Allowable Loading (kgf)	Weight (kg)	Material	Surface Finish
MX20-AC	20*20	X-axis	Central	±3.2	10	3	1	0.03	Aluminum alloy	Black anodized
MX20-AS			Side							
MY20-AC		XY-axis	Central							
MY20-AS			Side							

MX20-AC

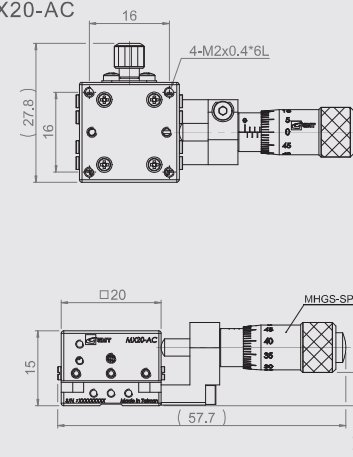

MX20-AS

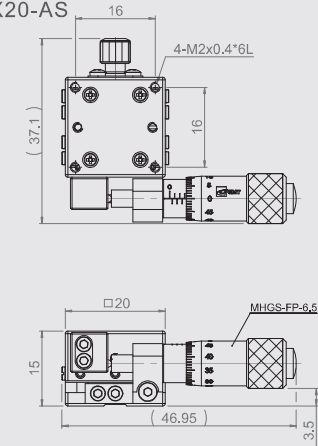

MY20-AC

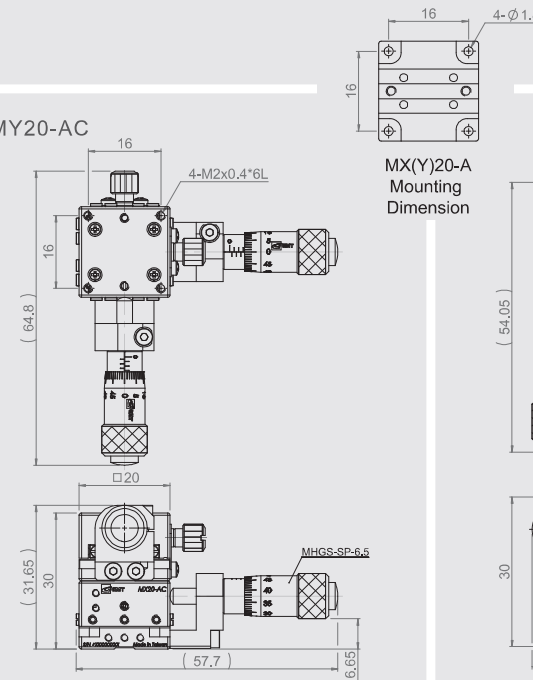

MY20-AS

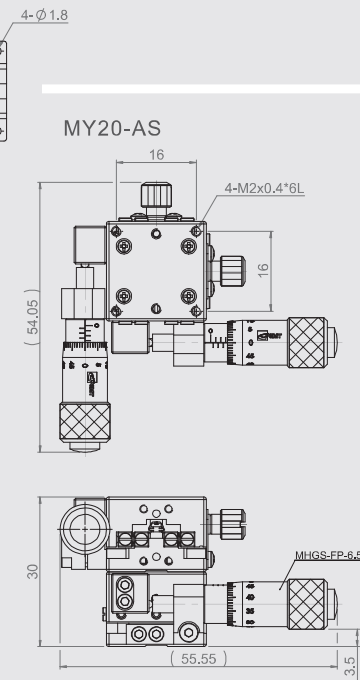

MX(Y)20-A
Mounting
Dimension

MX25-AC



MX25-AS



MY25-AC

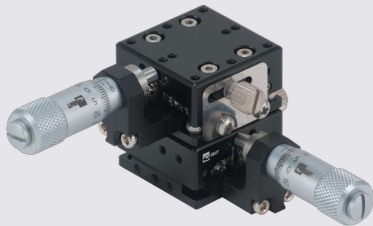

MY25-AS

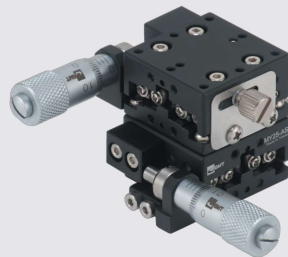

Specification

Unit : mm

Model No.	Table Size	Axis	Feed Position	Travel Stroke	Micrometer Minimum Reading (μm)	Straightness Accuracy (μm)	Allowable Loading (kgf)	Weight (kg)	Material	Surface Finish
MX25-AC	25*25	X-axis	Central	±3.2	10	3	1	0.04	Aluminum alloy	Black anodized
MX25-AS			Side							
MY25-AC		XY-axis	Central					0.08		
MY25-AS			Side							

MX25-AC

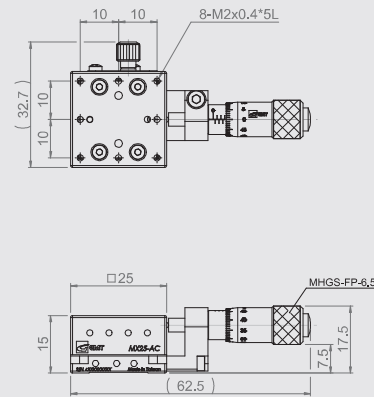

MX25-AS

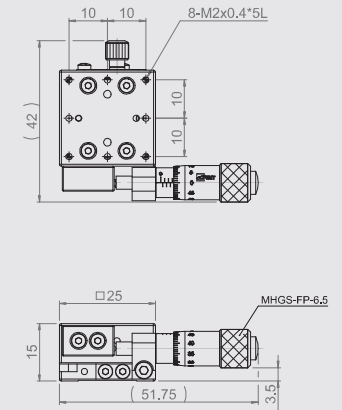

MY25-AC

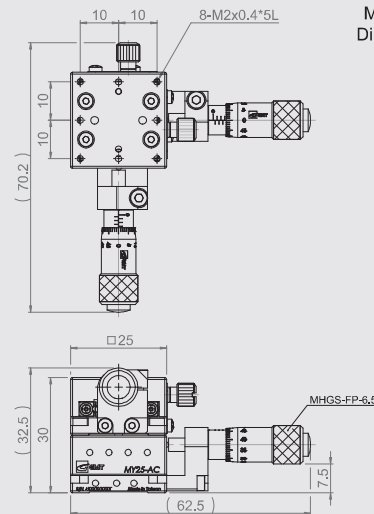

MY25-AS

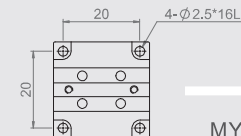
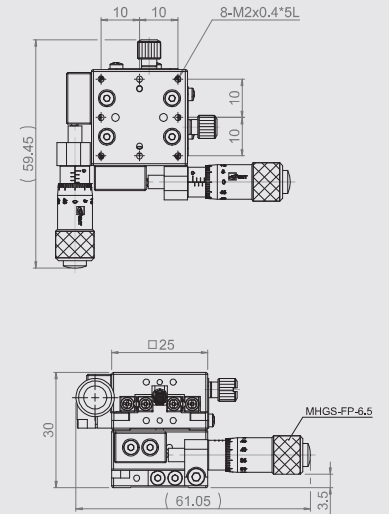

MX(Y)25-A
Mounting
Dimensions

MX30-AC



MX30-AS



MY30-AC

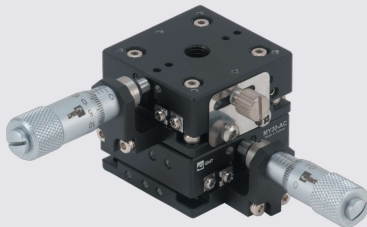

MY30-AS

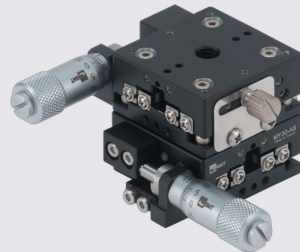

Specification

Unit : mm

Model No.	Table Size	Axis	Feed Position	Travel Stroke	Micrometer Minimum Reading (μm)	Straightness Accuracy (μm)	Allowable Loading (kgf)	Weight (kg)	Material	Surface Finish
MX30-AC	30*30	X-axis	Central	±3.2	10	3	1.2	0.045	Aluminum alloy	Black anodized
MX30-AS			Side							
MY30-AC		XY-axis	Central							
MY30-AS			Side							

MX30-AC

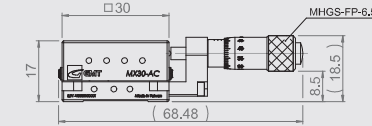
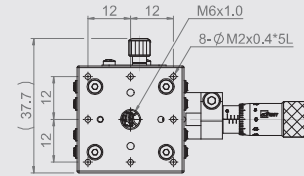

MX30-AS

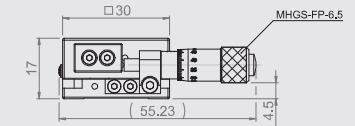
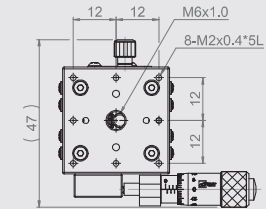

MY30-AC

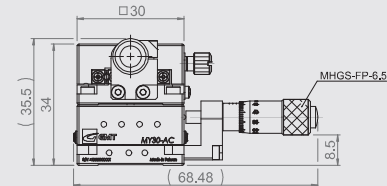
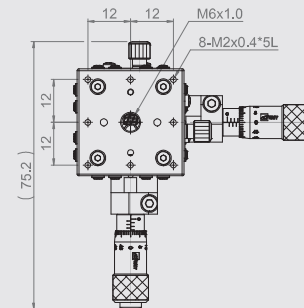

MY30-AS

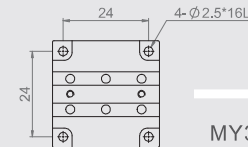
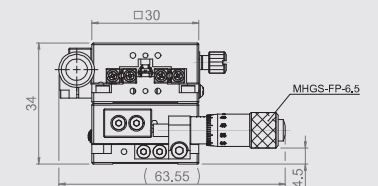
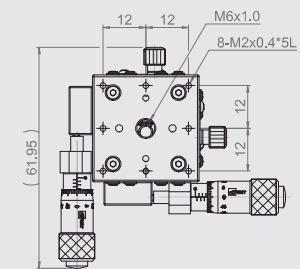

MX(Y)30-A
Mounting
Dimensions

MX40-AC



MX40-AS



MY40-AC



MY40-AS

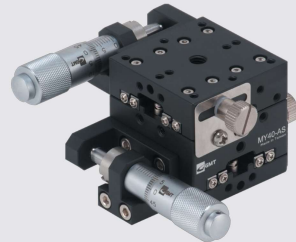

Specification

Unit : mm

Model No.	Table Size	Axis	Feed Position	Travel Stroke	Micrometer Minimum Reading (μ m)	Straightness Accuracy (μ m)	Allowable Loading (kgf)	Weight (kg)	Material	Surface Finish
MX40-AC	40*40	X-axis	Central	\pm 6.5	10	3	2	0.14	Aluminum alloy	Black anodized
MX40-AS			Side							
MY40-AC		XY-axis	Central							
MY40-AS			Side							

MX40-AC

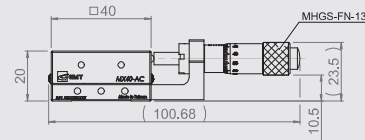
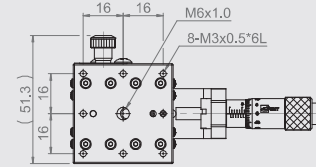

MX40-AS

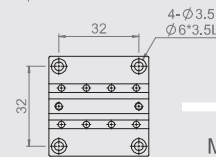
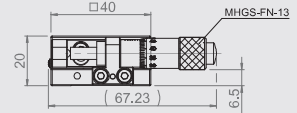
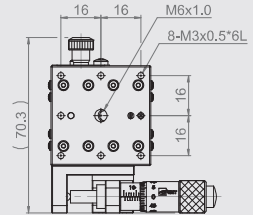

MY40-AC

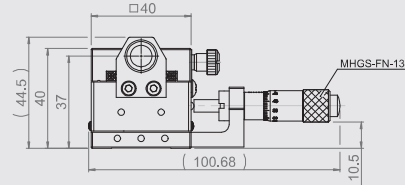
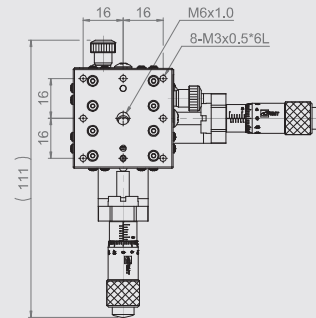

MY40-AS

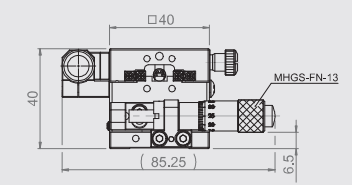
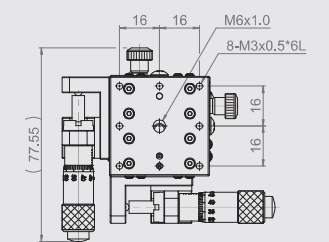

MX60-AC



MX60-AS



MY60-AC

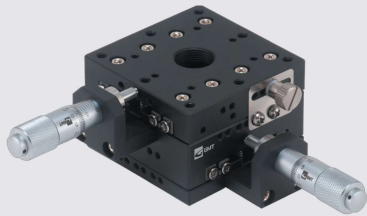

MY60-AS



Specification

Unit : mm

Model No.	Table Size	Axis	Feed Position	Travel Stroke	Micrometer Minimum Reading (μm)	Straightness Accuracy (μm)	Allowable Loading (kgf)	Weight (kg)	Material	Surface Finish
MX60-AC	60*60	X-axis	Central	±6.5	10	3	5	0.25	Aluminum alloy	Black anodized
MX60-AS			Side							
MY60-AC		XY-axis	Central				4.5			
MY60-AS			Side							

MX60-AC

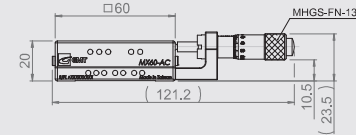
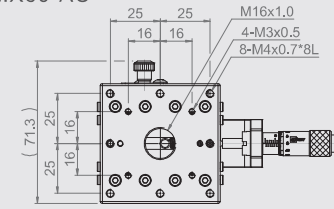

MX60-AS

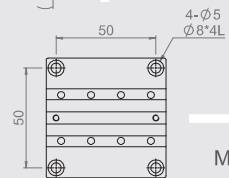
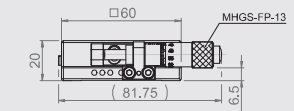
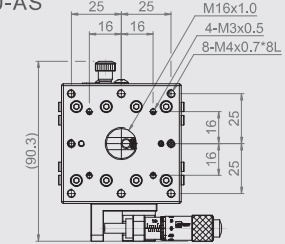

MX(Y)60-A
Mounting Dimensions

MY60-AC

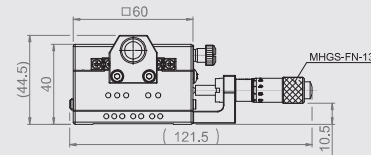
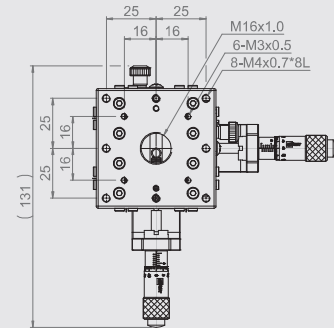

MY60-AS

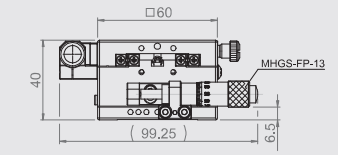
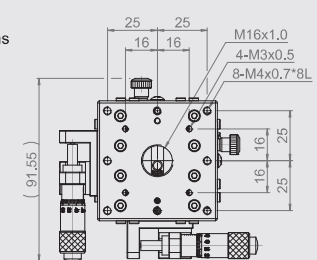

MX70-AC



MX70-AS

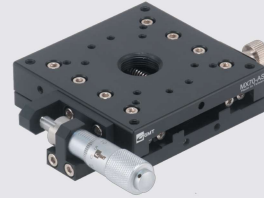

MY70-AC



MY70-AS

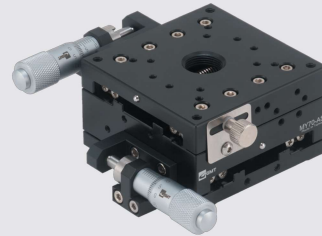

Specification

Unit : mm

Model No.	Table Size	Axis	Feed Position	Travel Stroke	Micrometer Minimum Reading (μm)	Straightness Accuracy (μm)	Allowable Loading (kgf)	Weight (kg)	Material	Surface Finish
MX70-AC	70*70	X-axis	Central	±6.5	10	3	6	0.44	Aluminum alloy	Black anodized
MX70-AS			Side							
MY70-AC		XY-axis	Central							
MY70-AS			Side							

MX70-AC

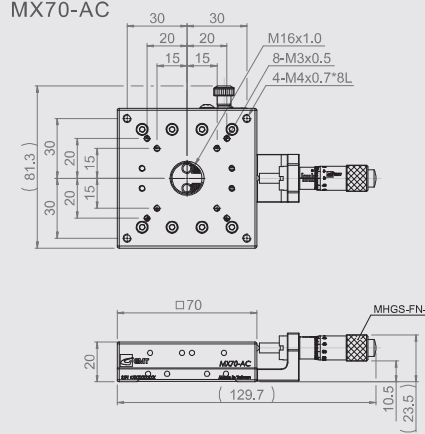

MX70-AS

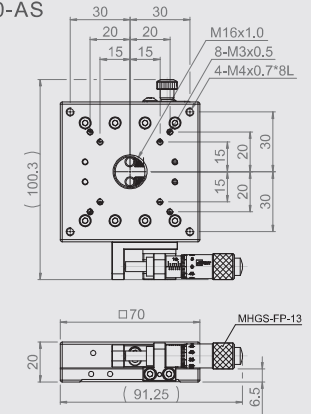

MY70-AC

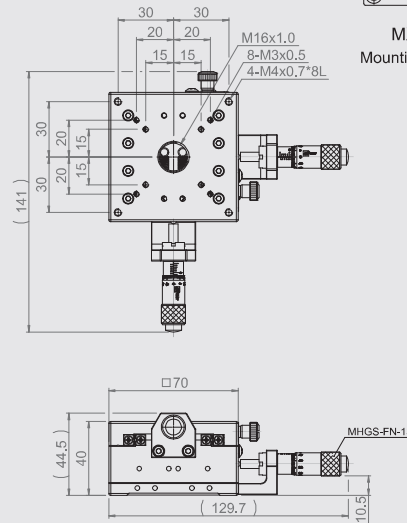

MY70-AS

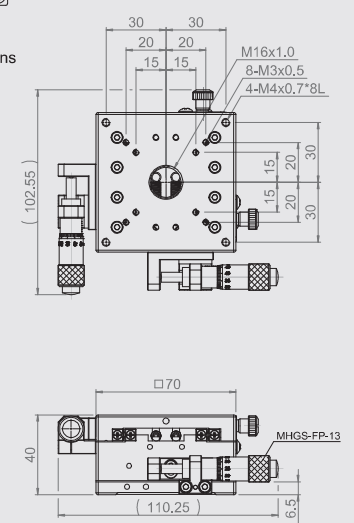

MX(Y)70-A
Mounting Dimensions

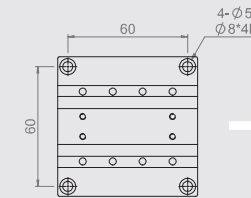

MX80-AC



MX80-AS

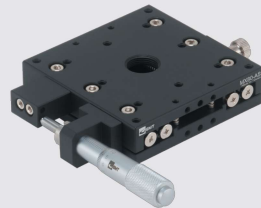

MY80-AC

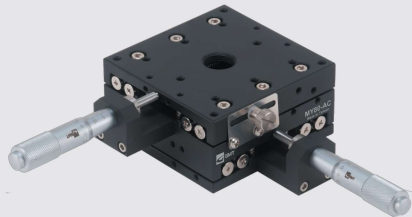

MY80-AS

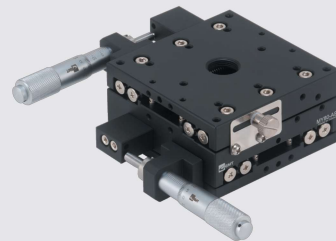

Specification

Unit : mm

Model No.	Table Size	Axis	Feed Position	Travel Stroke	Micrometer Minimum Reading (μm)	Straightness Accuracy (μm)	Allowable Loading (kgf)	Weight (kg)	Material	Surface Finish
MX80-AC	80*80	X-axis	Central	±12.5	10	3	10	0.5	Aluminum alloy	Black anodized
MX80-AS			Side							
MY80-AC		XY-axis	Central				9.5	1		
MY80-AS			Side							

MX80-AC

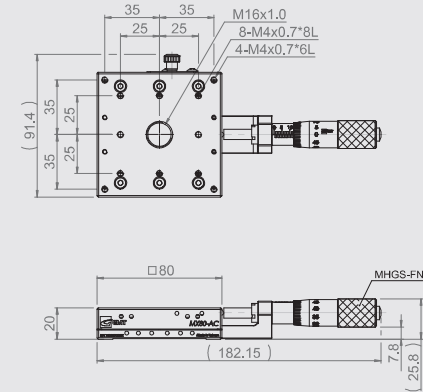

MX80-AS

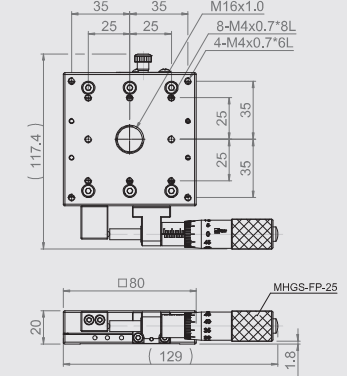

MY80-AC

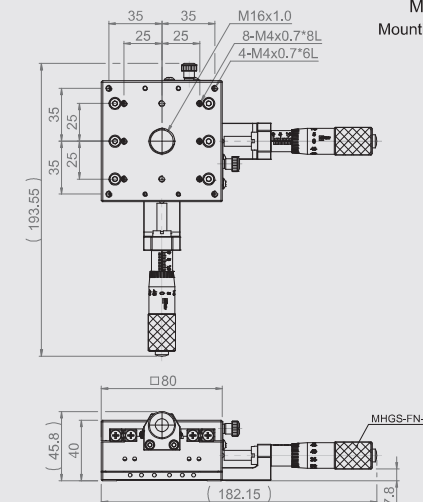

MY80-AS

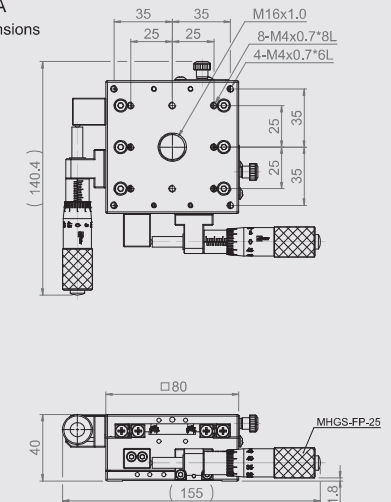

MX(Y)80-A
Mounting Dimensions

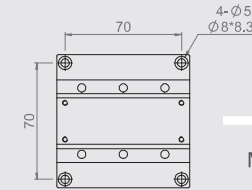

MX100-AC



MX100-AS



MY100-AC

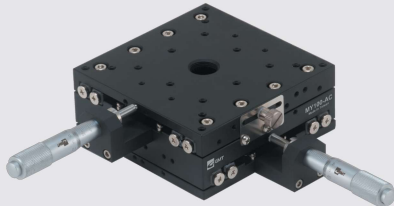

MY100-AS

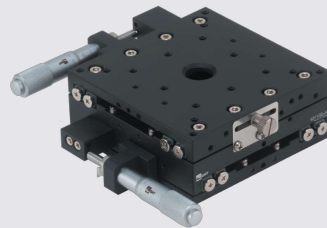

Specification

Unit : mm

Model No.	Table Size	Axis	Feed Position	Travel Stroke	Micrometer Minimum Reading (μm)	Straightness Accuracy (μm)	Allowable Loading (kgf)	Weight (kg)	Material	Surface Finish
MX100-AC	100*100	X-axis	Central	±12.5	10	3	15	0.7	Aluminum alloy	Black anodized
MX100-AS			Side							
MY100-AC		XY-axis	Central							
MY100-AS			Side							

MX100-AC

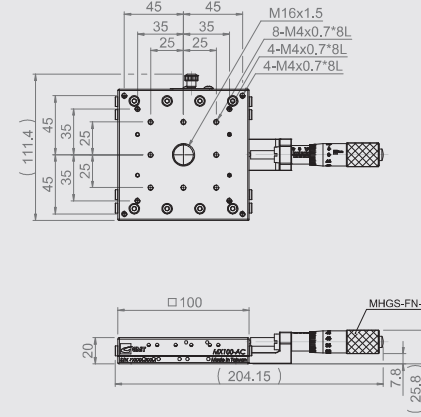

MX100-AS

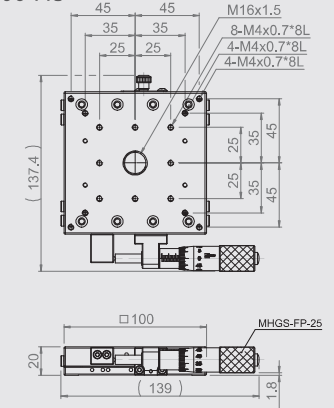

MY100-AC

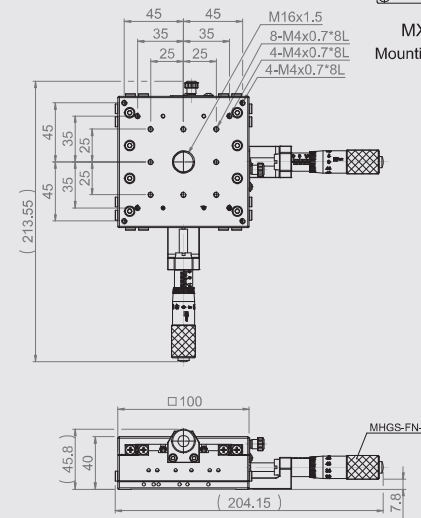

MY100-AS

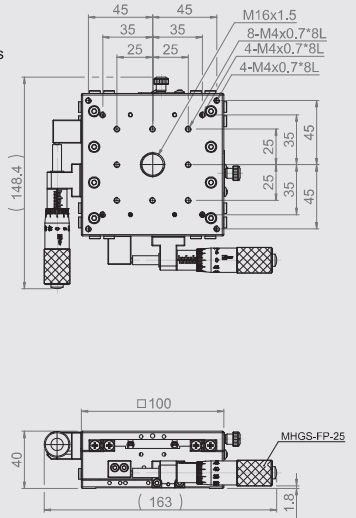

MX(Y)100-A
Mounting Dimensions

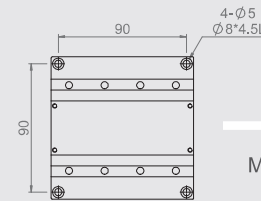

MX120-AC

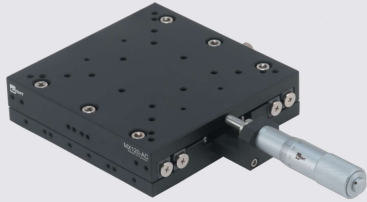

MX120-AS

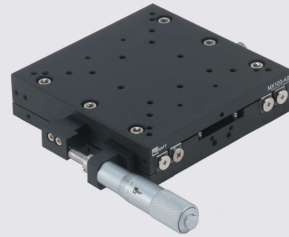

MY120-AC

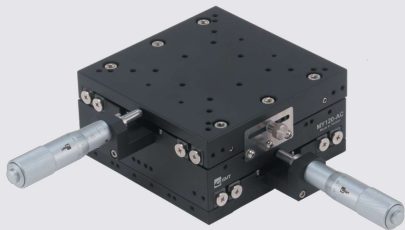

MY120-AS

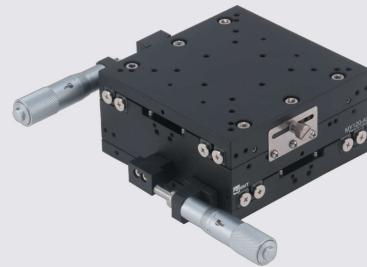

Specification

Unit : mm

Model No.	Table Size	Axis	Feed Position	Travel Stroke	Micrometer Minimum Reading (μm)	Straightness Accuracy (μm)	Allowable Loading (kgf)	Weight (kg)	Material	Surface Finish	
MX120-AC	120*120	X-axis	Central	±12.5	10	3	20	1.6	Aluminum alloy	Black anodized	
MX120-AS			Side								
MY120-AC		XY-axis	Central				18.4				3.2
MY120-AS			Side								

MX120-AC

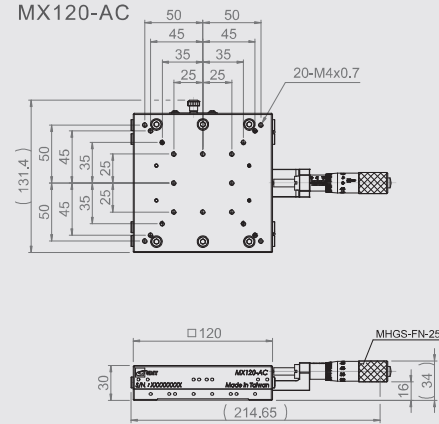

MX120-AS

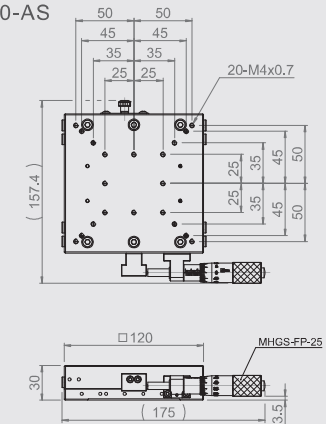

MY120-AC

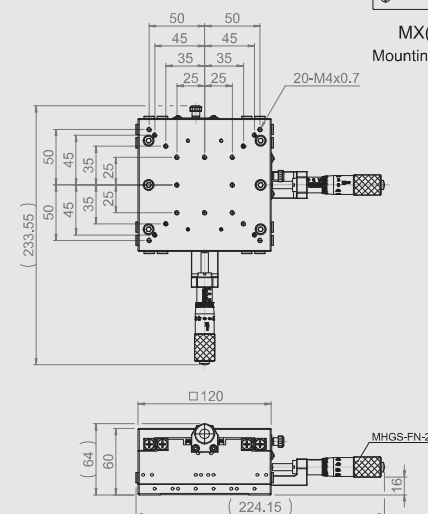

MY120-AS

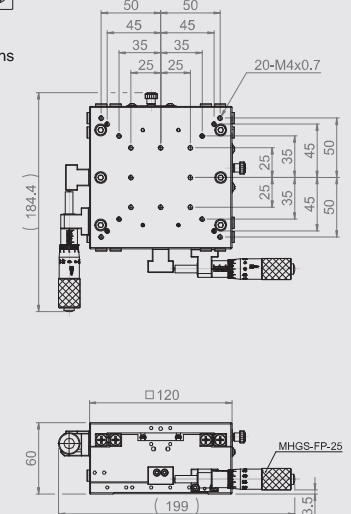

MX(Y)120-A
Mounting Dimensions

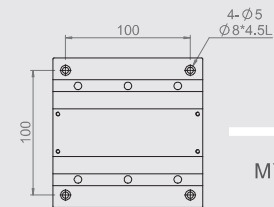

MZL60-ACR



Specification

Unit : mm

Model No.	Table Size	Travel Distance	Micrometer Minimum Reading (μm)	Movement Accuracy			Allowable Loading (kgf)	Weight (kg)	Material	Surface Finish
				Straightness (μm)	Pitching	Yawing				
MZL25-ACR	25*25	±3.2	10	3	25"	15"	0.5	0.06	Aluminum alloy	Black anodized
MZL40-ACR	40*40	±6.5					1.0	0.2		
MZL60-ACR	60*60	±12.5					2.0	0.45		
MZL80-ACR	80*80						5.0	0.8		

★ Brackets spec for Z-axis, refer to P.0195 ~ P.0196

MZL25-ACR

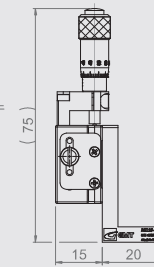
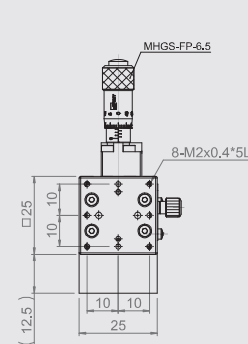
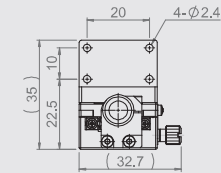

MZL40-ACR

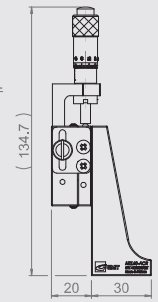
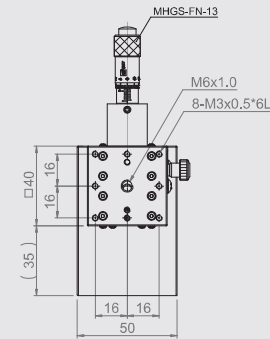
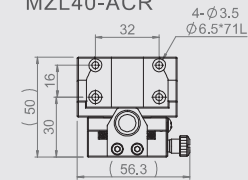

MZL60-ACR

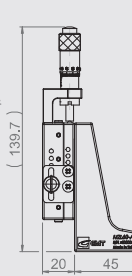
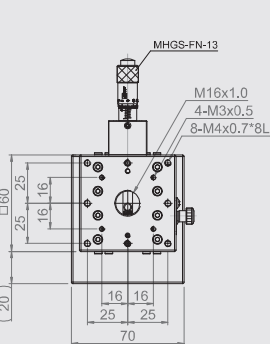
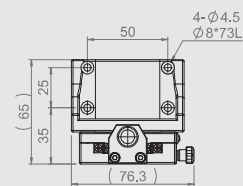

MZL80-ACR

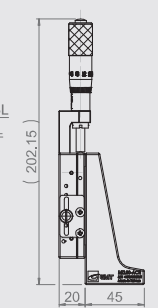
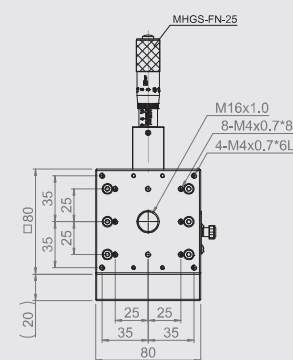
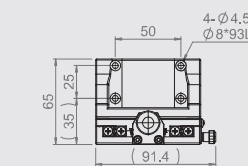

MZL25-AS

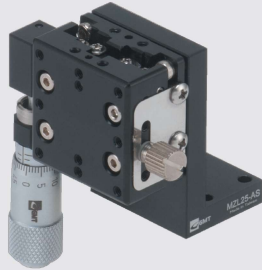

MZL40-AS

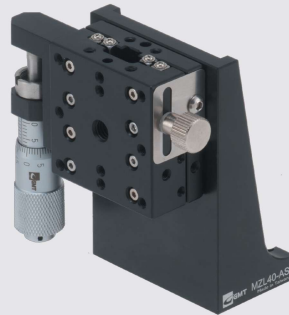

MZL60-AS



MZL80-AS



Specification

Unit : mm

Model No.	Table Size	Travel Distance	Micrometer Minimum (μm)	Movement Accuracy			Allowable Loading (kgf)	Weight (kg)	Material	Surface Finish
				Straightness (μm)	Pitching	Yawing				
MZL25-AS	25*25	±3.2	10	3	30"	20"	0.5	0.06	Aluminum alloy	Black anodized
MZL40-AS	40*40	±6.5					1.0	0.2		
MZL60-AS	60*60				2.0	0.45				
MZL80-AS	80*80				±12.5	5.0	0.8			

★ Brackets spec for Z-axis, refer to P.0195 - P.0196

MZL25-AS

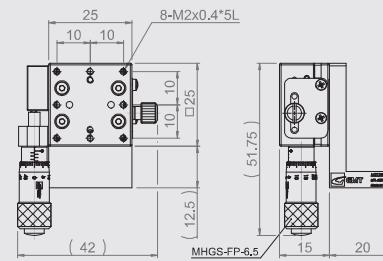
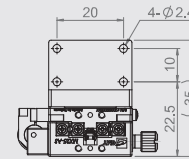

MZL40-AS

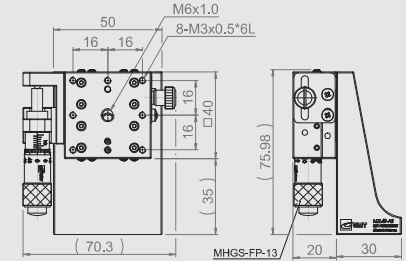
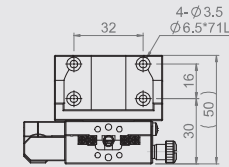

MZL60-AS

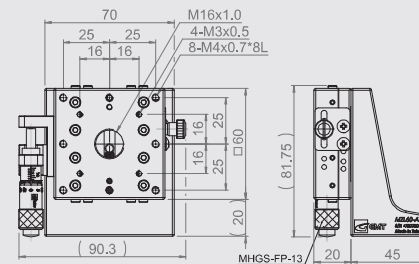
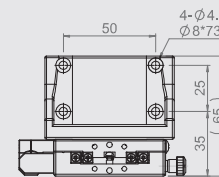

MZL80-AS

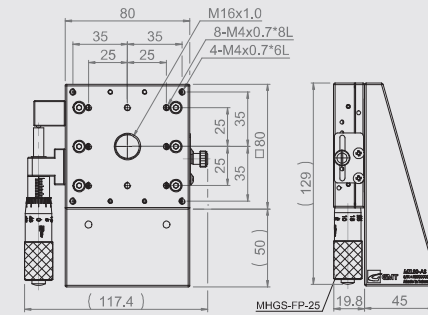
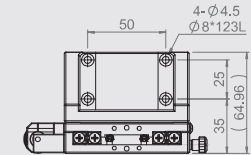

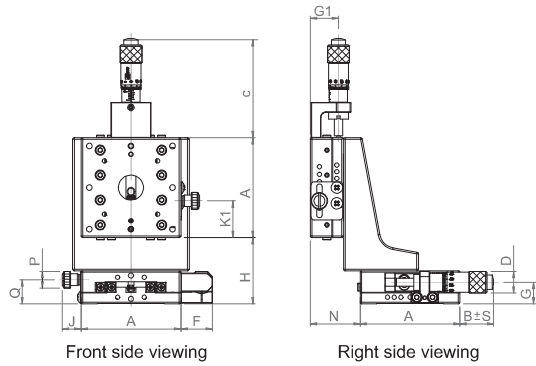

Unit : mm

Position of Micrometer

	Side up	Side down	Central	Reversed
Specification				
Code	C	CU	A	R

Specification

Unit : mm

Type	Detail Dimension from Front Side Viewing								Detail Dimensions from Right Side Viewing				
	A	H	C	K1	P	Q	J	F	B ± S (Movement)	N	D	G	G1
MXZ	25	27.6	37.5	15.1	6	10.6	7.7	9	26.7±3.2	10.1	10	8.5	12.5
	30	35	37.5	12.5	6	10.5	7.7	9	24.3±3.2	7	10	8.5	12.5
	40	55	62	28	10	14.5	11.2	19	26.3±6.5	10	13	13	17
	50	40	59.7	33	10	14.5	11.2	19	21.3±6.5	5	13	13	17
	60	39.9	59.7	17.4	10	14.4	11.2	19	20.2±6.5	5	13	13	17
	70	39.9	59.7	53.5	10	14.4	11.2	19	21.3±6.5	25	13	13	17
	80	40	100.7	25	10	14.5	11.2	24	54.5±12.5	20	18	10.8	16.5
	100	60	100.7	56	10	14.5	11.2	24	35.5±12.5	36	18	10.8	16.7
	120	65	100.7	52	10	18	11.2	24	51.5±12.5	7	18	12.5	17.5

Model No.	Table Size	Allowable Loading (kgf)	Straightness Accuracy (μm)	Pitching	Yawing	Axis	Weight (kg)	Material	Surface Finish
MXZ25-A	25*25	1							
MXZ30-A	30*30								
MXZ40-A	40*40								
MXZ50-A	50*50								
MXZ60-A	60*60	2	5	25"	15"	XZ	0.74	Aluminum alloy	Black anodized
MXZ70-A	70*70								
MXZ80-A	80*80								
MXZ100-A	100*100	5	5	25"	15"	XZ	2.39	Aluminum alloy	Black anodized
MXZ120-A	120*120								

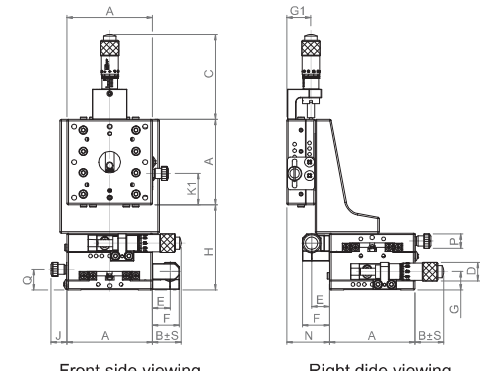

Unit : mm

Position of Micrometer

	Side up	Side down	Central	Reversed
Specification				
Code	C	CU	A	R

Specification

Unit : mm

Type	Detail Dimension from Front Side Viewing								Detail Dimensions from Right Side Viewing					
	A	H	C	K1	Q	J	F	E	B ± S (Movement)	N	D	G	G1	P
MXYZ	25	42.6	37.5	15	10.6	7.7	9	4.5	26.8±3.2	20.1	10	8.5	12.5	6
	30	50	37.5	12.5	10.5	7.7	9	4.5	24.3±3.2	19	10	8.5	12.5	6
	40	75	59.7	28	14.5	11.2	19	12.5	26.3±6.5	26	13	13	17	10
	50	60	59.7	33	14.5	11.2	19	12.5	21.3±6.5	25	13	13	17	10
	60	60	59.7	17.5	14.4	11.2	19	12.5	20.3±6.5	30	13	13	17	10
	70	60	59.7	53.5	14.4	11.2	19	12.5	21.3±6.5	25	13	13	17	10
	80	60	100.7	25	14.5	11.2	24	17	54.5±12.5	20	13	10.8	16.5	10
	100	80	100.7	56	14.5	11.2	24	17	35.5±12.5	36	18	10.8	16.7	10
	120	95	100.7	52	18	11.2	24	17	51.5±12.5	27	18	12.5	17.5	10

Model No.	Table Size	Allowable Loading (kgf)	Straightness Accuracy (μm)	Pitching	Yawing	Axis	Weight (kg)	Material	Surface Finish
MXYZ25-A	25*25	1							
MXYZ30-A	30*30								
MXYZ40-A	40*40								
MXYZ50-A	50*50								
MXYZ60-A	60*60	2	5	25"	15"	XYZ	1.01	Aluminum alloy	Black anodized
MXYZ70-A	70*70								
MXYZ80-A	80*80								
MXYZ100-A	100*100	5	5	25"	15"	XYZ	3.12	Aluminum alloy	Black anodized
MXYZ120-A	120*120								

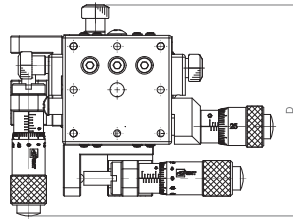

Top viewing

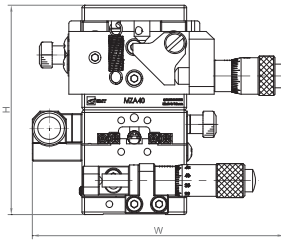

Front side viewing

Model No. Spec Code	Multiple Axes			Table Size (mm)	Outline Dimensions (mm)			Travel Stroke (mm)				Allowable Loading (kgf)	Weight (kg)
	Base	Middle	Top		W	D	H	X	Y	Z	θ		
MXYZA40-A	MY40-AS	—	MZA-40	40×40	96.25	77.45	80	±6.5	±6.5	±3.0	—	1	0.51
MXYZA60-A	MY60-AS	—	MZA-60	60×60	117.5	91.45	95	±6.5	±6.5	±5.0	—	4	1.07
MXYZA80-A	MY80-AS	—	MZA-80	80×80	160.5	145.7	95	±12.5	±12.5	—	—	3	2.09

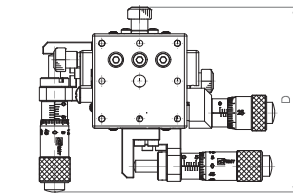

Top viewing

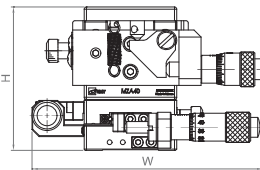

Front side viewing

Model No. Spec Code	Multiple Axes			Table Size (mm)	Outline Dimensions (mm)			Travel Stroke (mm)				Allowable Loading (kgf)	Weight (kg)
	Base	Middle	Top		W	D	H	X	Y	Z	θ		
MXYWZA40-A	MYW40-AS	—	MZA-40	40×40	99.75	78.2	62	±6.5	±6.5	±3.0	—	0.8	0.44
MXYWZA60-A	MYW60-AS	—	MZA-60	60×60	121	96.2	77	±6.5	±6.5	±5.0	—	2.4	0.9
MXYWZA80-A	MYW80-AS	—	MZA-80	80×80	154.5	126.7	77	±12.5	±12.5	±5.0	—	3	1.82

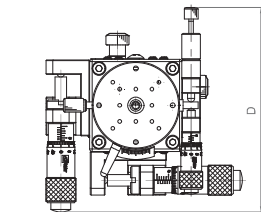

Top viewing

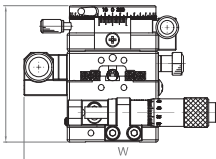

Front side viewing

Model No. Spec Code	Multiple Axes			Table Size (mm)	Outline Dimensions (mm)			Travel Stroke (mm)				Allowable Loading (kgf)	Weight (kg)
	Base	Middle	Top		W	D	H	X	Y	Z	θ		
MXYR38-A	MY40-AS	—	MR38-A	Ø38	85.25	88.75	60	±6.5	±6.5	—	—	1	0.42
MXYR60-A	MY60-AS	—	MR60-A	Ø60	99.25	109	65	±6.5	±6.5	—	—	3	0.87
MXYR85-A	MY80-AS	—	MR85-A	Ø85	160.5	150	65	±12.5	±12.5	—	—	4	1.62

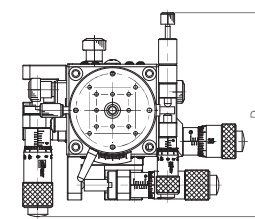

Top viewing

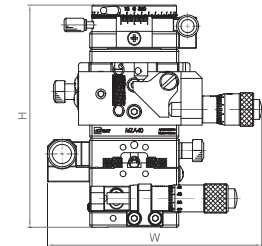

Front side viewing

Model No. Spec Code	Multiple Axes			Table Size (mm)	Outline Dimensions (mm)			Travel Stroke (mm)				Allowable Loading (kgf)	Weight (kg)
	Base	Middle	Top		W	D	H	X	Y	Z	θ		
MXYZAR38-A	MY40-AS	MZA-40	MR38-A	Ø38	96.25	88.75	100	±6.5	±6.5	±3.0	—	0.9	0.63
MXYZAR60-A	MY60-AS	MZA-60	MR60-A	Ø60	117.5	109	119.5	±6.5	±6.5	±5.0	Coarse360° Fine±0.5°	3	1.4
MXYZAR85-A	MY80-AS	MZA-80	MR85-A	Ø85	160.5	150	120	±12.5	±12.5	±5.0	—	2.5	2.64

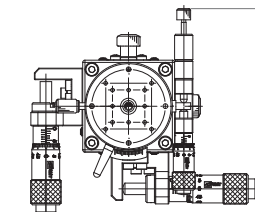

Top viewing

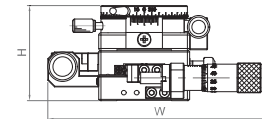

Front side viewing

Model No. Spec Code	Multiple Axes			Table Size (mm)	Outline Dimensions (mm)			Travel Stroke (mm)				Allowable Loading (kgf)	Weight (kg)
	Base	Middle	Top		W	D	H	X	Y	Z	θ		
MXYWR38-A	MYW40-AS	—	MR38-A	Ø38	98.5	89.5	42	±6.5	±6.5	±3.0	—	0.9	0.35
MXYWR60-A	MYW60-AS	—	MR60-A	Ø60	103	109	47	±6.5	±6.5	±5.0	Coarse360° Fine±0.5°	2.7	0.7
MXYWR85-A	MYW80-AS	—	MR85-A	Ø85	153.5	130	47	±12.5	±12.6	±5.0	—	3.5	1.34

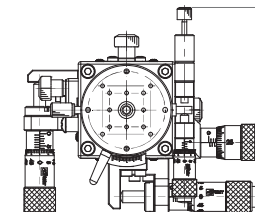

Top viewing

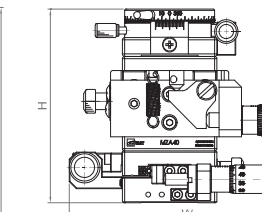

Front side viewing

Model No. Spec Code	Multiple Axes			Table Size (mm)	Outline Dimensions (mm)			Travel Stroke (mm)				Allowable Loading (kgf)	Weight (kg)
	Base	Middle	Top		W	D	H	X	Y	Z	θ		
MXYWZAR38-A	MYW40-AS	MZA-40	MR38-A	Ø38	99.75	89.5	82	±6.5	±6.5	±3.0	—	0.7	0.57
MXYWZAR60-A	MYW60-AS	MZA-60	MR60-A	Ø60	121	109	102	±6.5	±6.5	±5.0	Coarse360° Fine±0.5°	2.1	1.23
MXYWZAR85-A	MYW80-AS	MZA-80	MR85-A	Ø85	154.5	131	102	±12.5	±12.5	±5.0	—	2.5	2.36

MXL40-AC



MXL40-AS



MYL40-AC



MYL40-AS

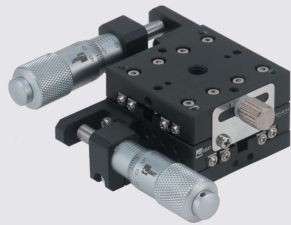

Specification

Unit : mm

Model No.	Table Size	Axis	Feed Position	Travel Stroke	Micrometer Minimum Reading (μm)	Straightness Accuracy (μm)	Allowable Loading (kgf)	Weight (kg)	Material	Surface Finish	
MXL40-AC	40*40	X-axis	Central	±6.5	10	3	3	0.13	Aluminum alloy	Black anodized	
MXL40-AS			Side								
MYL40-AC		XY-axis	Central								0.23
MYL40-AS			Side								

MXL40-AC

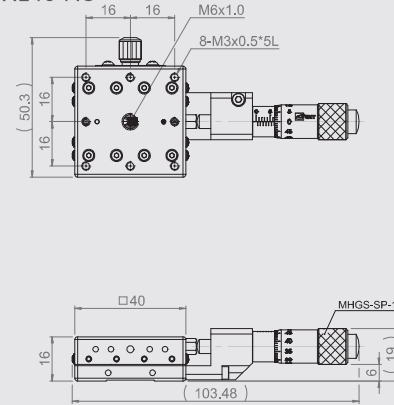

MXL40-AS

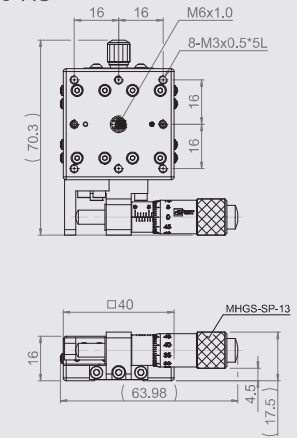

MYL40-AC

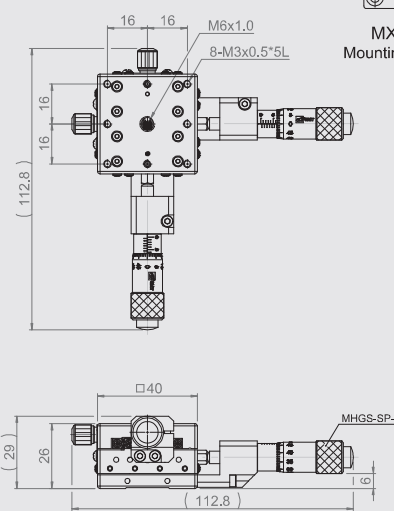

MYL40-AS

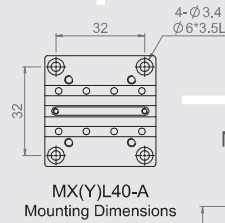
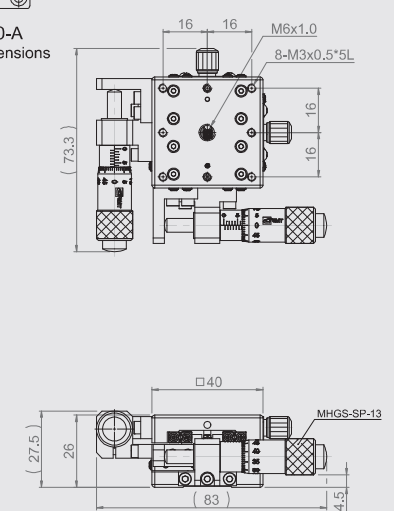

MX(Y)L40-A
Mounting Dimensions

MXL60-AC



MXL60-AS

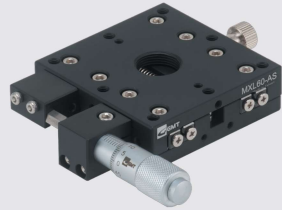

MYL60-AC



MYL60-AS

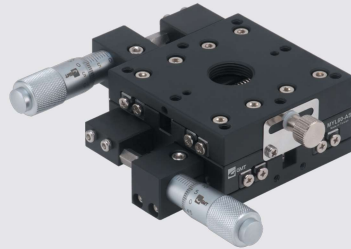

Specification

Unit : mm

Model No.	Table Size	Axis	Feed Position	Travel Stroke	Micrometer Minimum Reading (μm)	Straightness Accuracy (μm)	Allowable Loading (kgf)	Weight (kg)	Material	Surface Finish
MXL60-AC	60*60	X-axis	Central	±6.5	10	3	5	0.3	Aluminum alloy	Black anodized
MXL60-AS			Side							
MYL60-AC		XY-axis	Central					0.5		
MYL60-AS			Side							

MXL60-AC

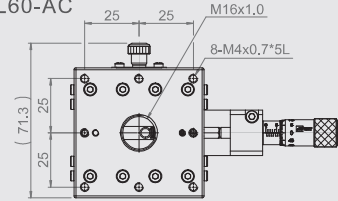

MXL60-AS

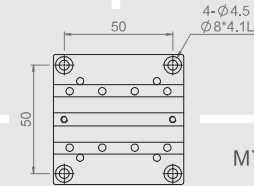
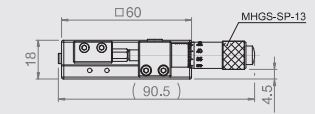
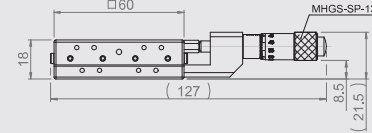
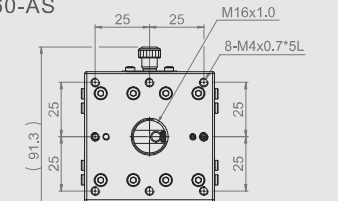

MYL60-AC

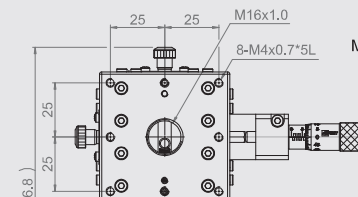

MYL60-AS

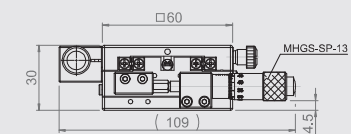
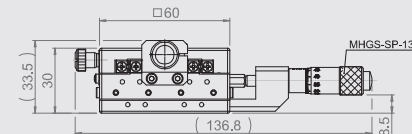
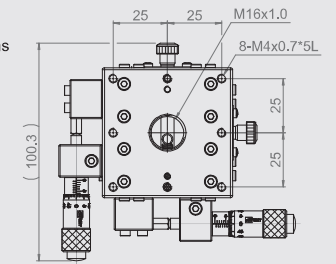

MX(Y)L60-A
Mounting Dimensions

MXL90-AC

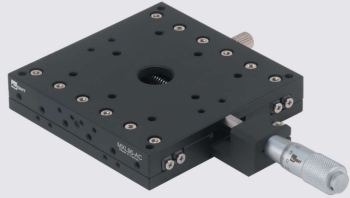

MXL90-AS

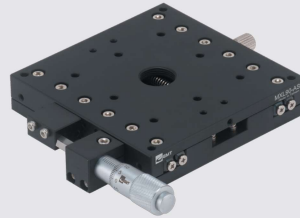

MYL90-AC

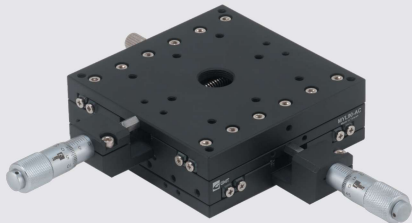

MYL90-AS

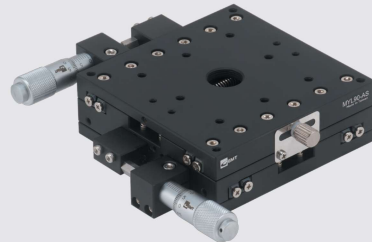

Specification

Unit : mm

Model No.	Table Size	Axis	Feed Position	Travel Stroke	Micrometer Minimum Reading (μm)	Straightness Accuracy (μm)	Allowable Loading (kgf)	Weight (kg)	Material	Surface Finish
MXL90-AC	90°90	X-axis	Central	±7.5	10	3	8	0.45	Aluminum alloy	Black anodized
MXL90-AS			Side							
MYL90-AC		XY-axis	Central							
MYL90-AS			Side							

MXL90-AC

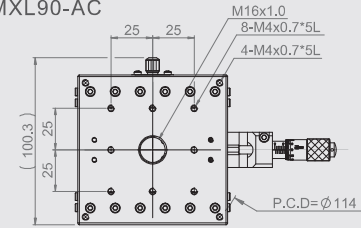

MXL90-AS

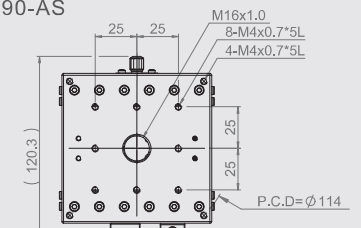

MYL90-AC

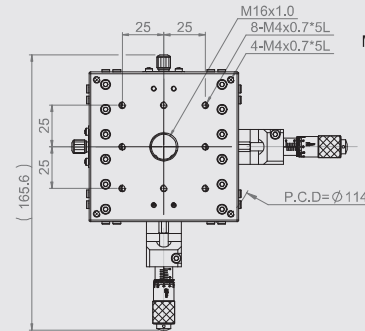

MYL90-AS

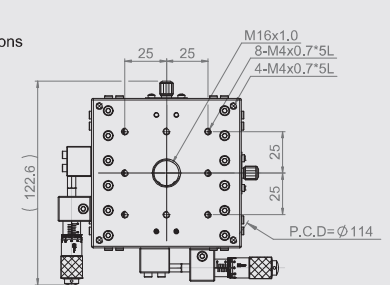

MX(Y)L90-A
Mounting Dimensions

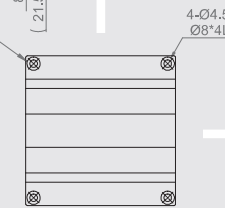

MXL125-AC

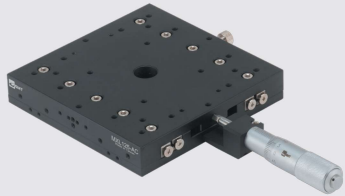

MXL125-AS

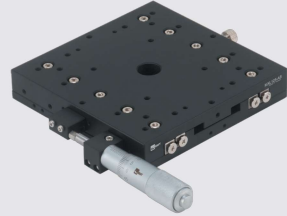

MYL125-AC



MYL125-AS

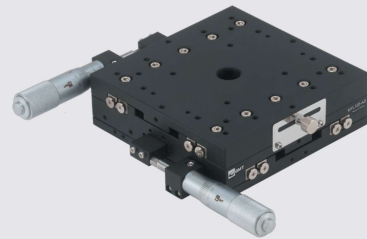

Specification

Unit : mm

Model No.	Table Size	Axis	Feed Position	Travel Stroke	Micrometer Minimum Reading (μm)	Straightness Accuracy (μm)	Allowable Loading (kgf)	Weight (kg)	Material	Surface Finish
MXL125-AC	125*125	X-axis	Central	±12.5	10	3	15	1.1	Aluminum alloy	Black anodized
MXL125-AS			Side							
MYL125-AC		XY-axis	Central							
MYL125-AS			Side							

MXL125-AC

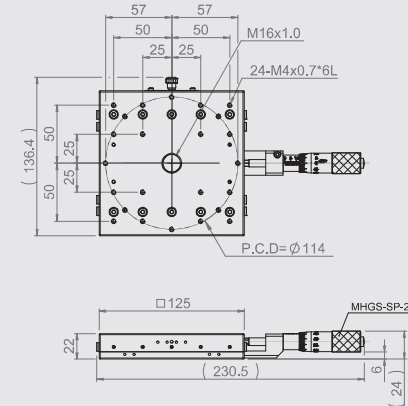

MXL125-AS

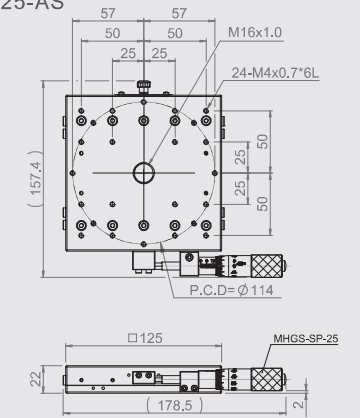

MYL125-AC

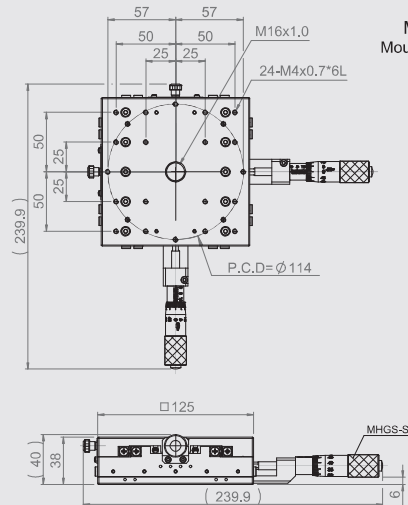

MYL125-AS

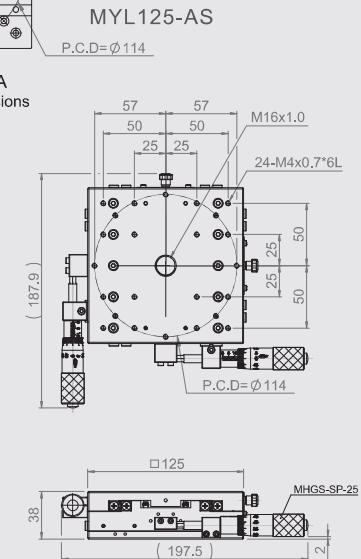

MX(Y)L125-A
Mounting Dimensions

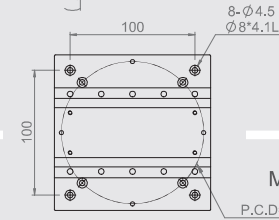

MLZ30-ASZ



MLZ40-ASZ



MLZ60-ASZ



MLZ90-ASZ



Specification

Unit : mm

Model No.	Table Size	Axis	Feed Position	Travel Stroke	Micrometer Minimum Reading (μm)	Straightness Accuracy (μm)	Allowable Loading (kgf)	Weight (kg)	Material	Surface Finish
MLZ30-ASZ	30*30	X+L bracket	Side	±3.2	10	3	1.5	0.1	Aluminum alloy	Black anodized
MLZ40-ASZ	40*40			±6.5			1.5	0.21		
MLZ60-ASZ	60*60			±7.5			2	0.52		
MLZ90-ASZ	90*90			±7.5			3	0.91		

MLZ30-ASZ

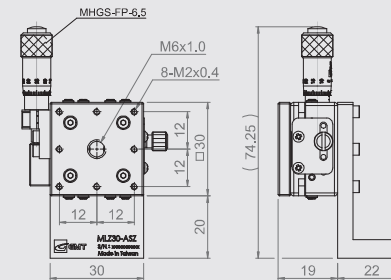
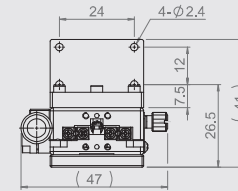

MLZ40-ASZ

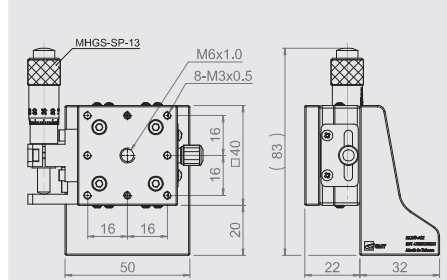
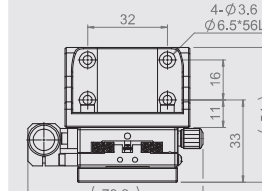

MLZ60-ASZ

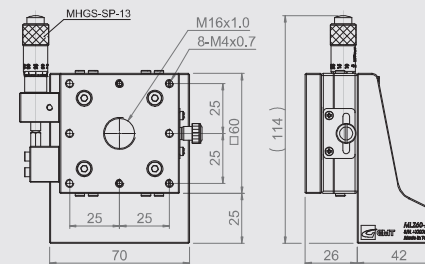
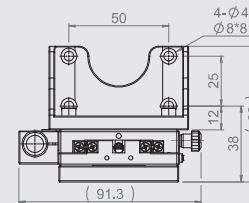

MLZ90-ASZ

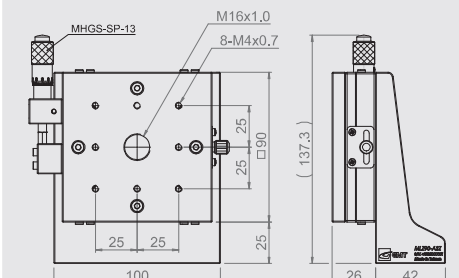
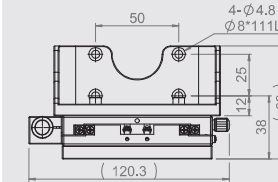

MYW40-AS

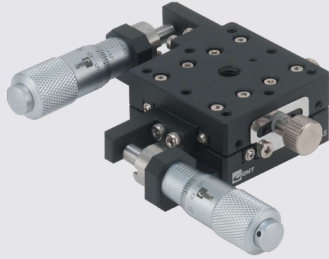

MYW60-AS

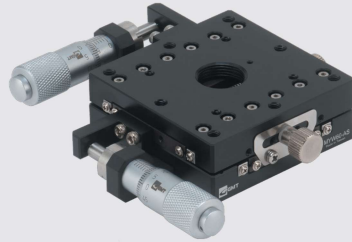

MYW80-AS

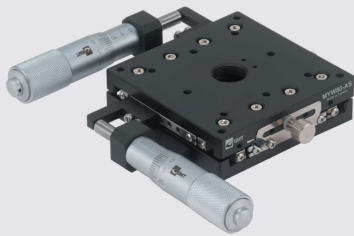

MYW100-AS



Specification

Unit : mm

Model No.	Table Size	Axis	Feed Position	Travel Stroke	Micrometer Minimum Reading (μm)	Straightness Accuracy (μm)	Allowable Loading (kgf)	Weight (kg)	Material	Surface Finish
MYW40-AS	40*40	XY-axis	Side	±6.5	10	3	1	0.2	Aluminum alloy	Black anodized
MYW60-AS	60*60						3	0.4		
MYW80-AS	80*80			4			0.7			
MYW100-AS	100*100			4			1.1			

MYW40-AS

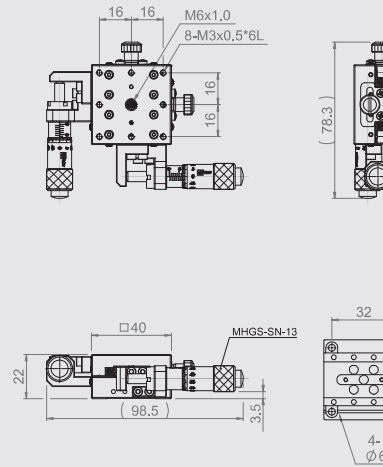

MYW60-AS

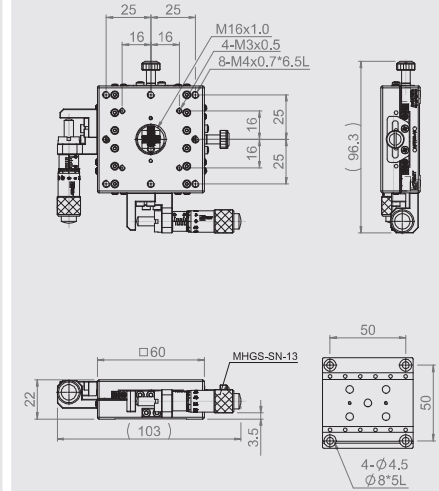

MYW80-AS

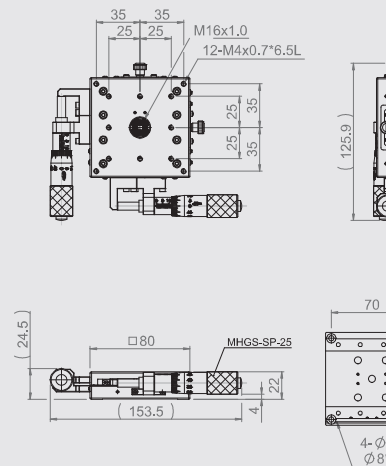

MYW100-AS

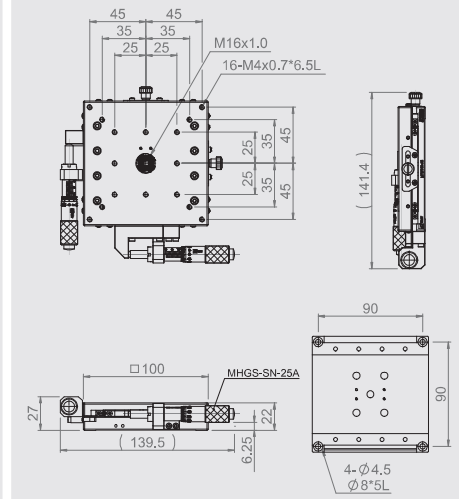

MYW40-AC

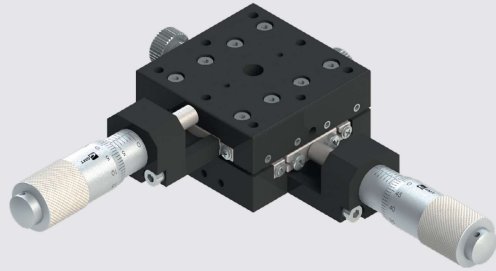

MYW60-AC



Specification

Unit : mm

Model No.	Table Size	Axis	Feed Position	Travel Stroke	Micrometer Minimum Reading (μm)	Straightness Accuracy (μm)	Allowable Loading (kgf)	Weight (kg)	Material	Surface Finish
MYW40-AC	40*40	XY-axis	Central	±6.5	10	3	1	1	Aluminum alloy	Black anodized
MYW60-AC	60*60							3		

MYW40-AC

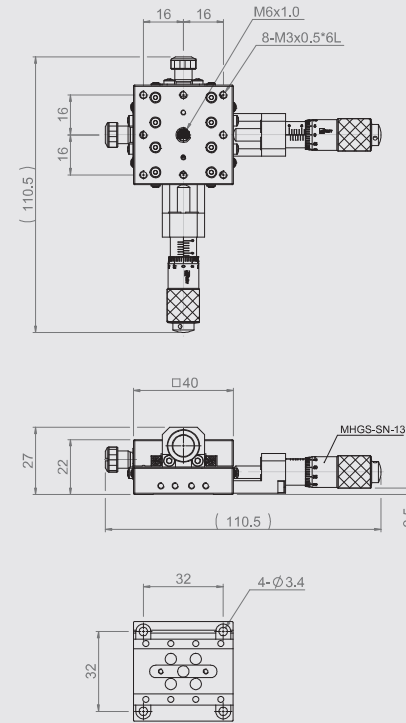

MYW60-AC

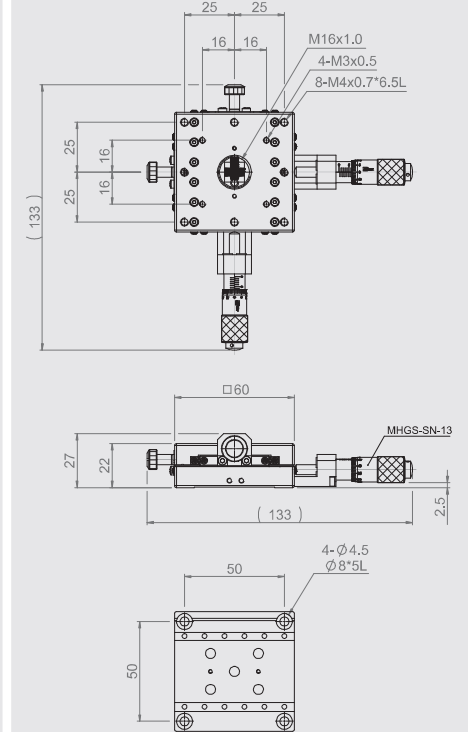

MX25-AC-18



MX25-AS-18



MY25-AC-18

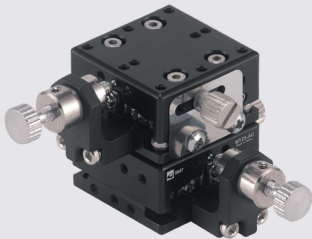

MY25-AS-18

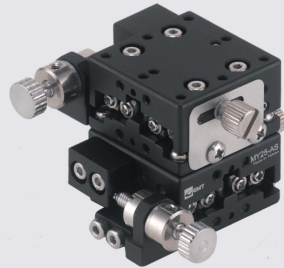

Specification

Unit : mm

Model No.	Table Size	Axis	Feed Position	Travel Stroke	Movement Per Knob Rotation (μm)	Straightness Accuracy (μm)	Allowable Loading (kgf)	Weight (kg)	Material	Surface Finish
MX25-AC-18	25*25	X-axis	Central	±3.2	50	3	1	0.04	Aluminum alloy	Black anodized
MX25-AS-18			Side							
MY25-AC-18		XY-axis	Central							
MY25-AS-18			Side							

MX25-AC-18

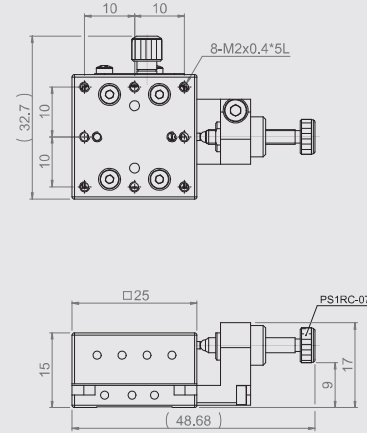

MX25-AS-18

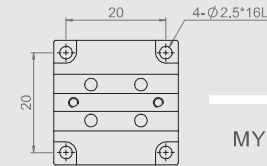
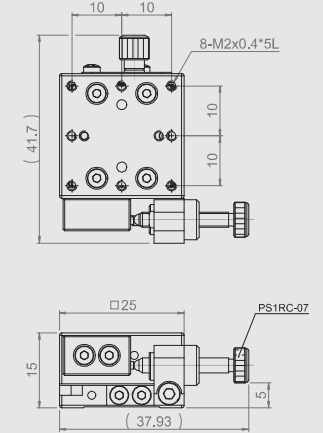

MX(Y)25-A-18
Mounting Dimensions

MY25-AC-18

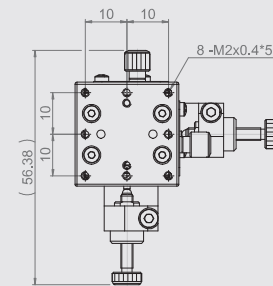

MY25-AS-18

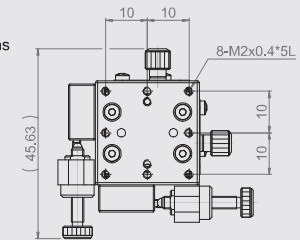

MX30-AC-18



MX30-AS-18



MY30-AC-18



MY30-AS-18

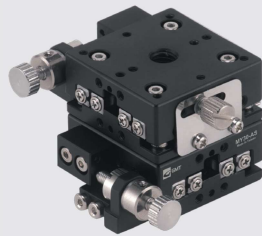

Specification

Unit : mm

Model No.	Table Size	Axis	Feed Position	Travel Stroke	Movement Per Knob Rotation (μm)	Straightness Accuracy (μm)	Allowable Loading (kgf)	Weight (kg)	Material	Surface Finish
MX30-AC-18	30*30	X-axis	Central	±3.2	50	3	1	0.045	Aluminum alloy	Black anodized
MX30-AS-18			Side							
MY30-AC-18		XY-axis	Central							
MY30-AS-18			Side							

MX30-AC-18

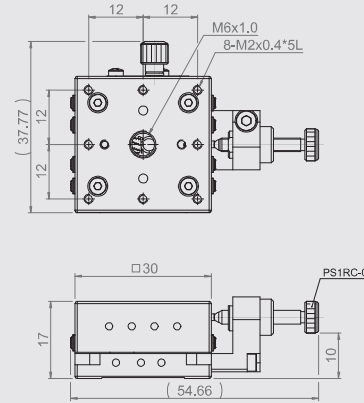

MX30-AS-18

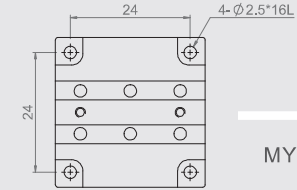
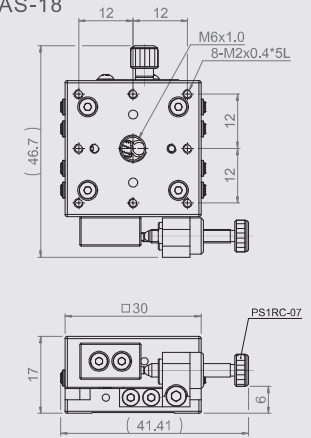

MY30-AC-18

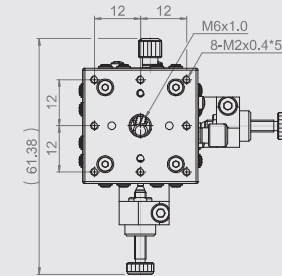

MY30-AS-18

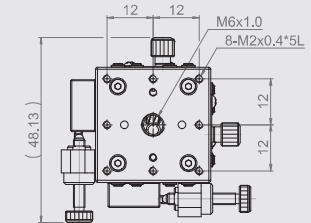

MX(Y)30-A-18
Mounting Dimensions

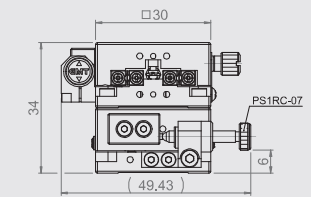
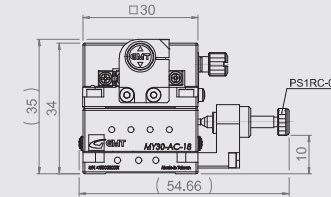

MX40-AC-18



MX40-AS-18

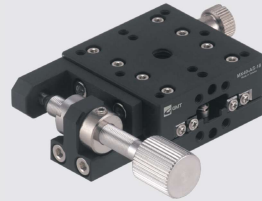

MY40-AC-18



MY40-AS-18

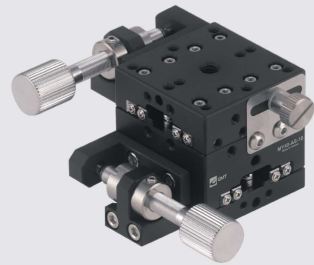

Specification

Unit : mm

Model No.	Table Size	Axis	Feed Position	Travel Stroke	Movement Per Knob Rotation (μm)	Straightness Accuracy (μm)	Allowable Loading (kgf)	Weight (kg)	Material	Surface Finish
MX40-AC-18	40*40	X-axis	Central	±6.5	50	3	2	0.14	Aluminum alloy	Black anodized
MX40-AS-18			Side							
MY40-AC-18		XY-axis	Central				1.8	0.30		
MY40-AS-18			Side							

MX40-AC-18

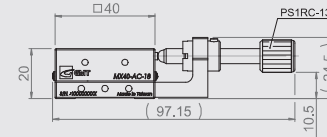
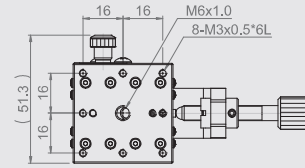

MX40-AS-18

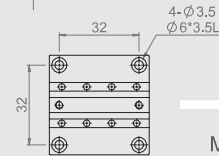
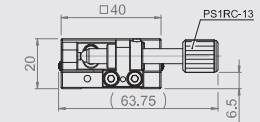
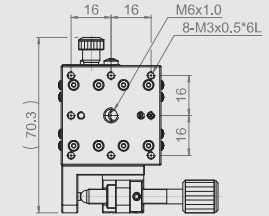

MX(Y)40-A-18
Mounting Dimensions

MY40-AC-18

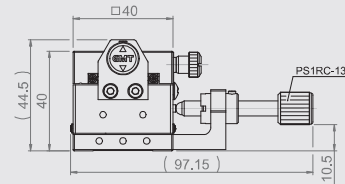
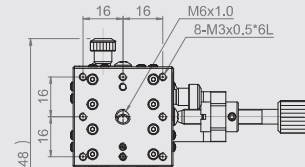

MY40-AS-18

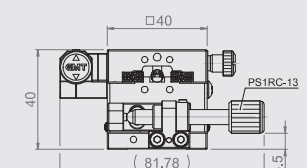
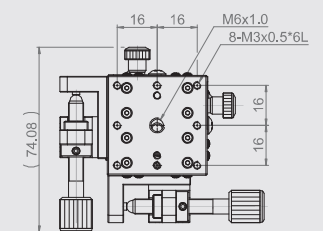

MX60-AC-18



MX60-AS-18



MY60-AC-18



MY60-AS-18

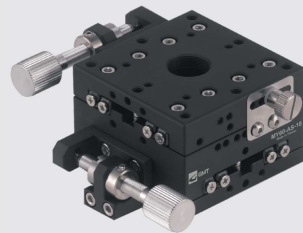

Specification

Unit : mm

Model No.	Table Size	Axis	Feed Position	Travel Stroke	Movement Per Knob Rotation (μm)	Straightness Accuracy (μm)	Allowable Loading (kgf)	Weight (kg)	Material	Surface Finish
MX60-AC-18	60*60	X-axis	Central	±6.5	50	3	5	0.25	Aluminum alloy	Black anodized
MX60-AS-18			Side							
MY60-AC-18		XY-axis	Central				4.5	0.52		
MY60-AS-18			Side							

MX60-AC-18

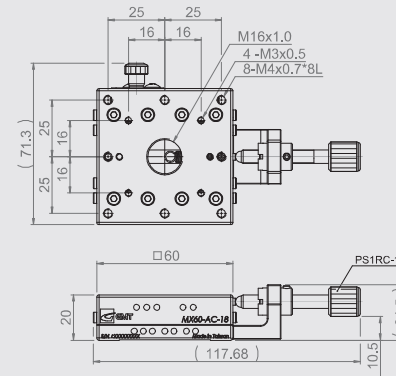

MX60-AS-18

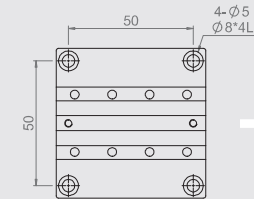
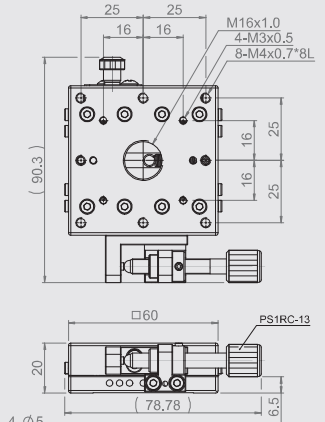

MY60-AC-18

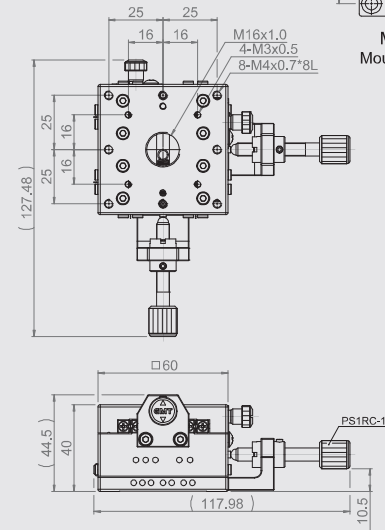

MY60-AS-18

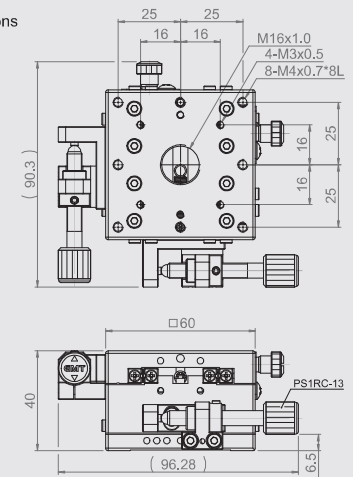

MX100-AC-18

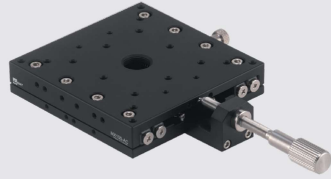

MX100-AS-18



MY100-AC-18

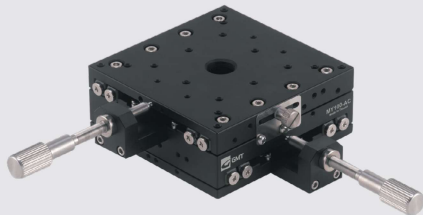

MY100-AS-18

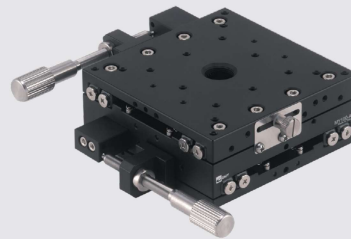

MX100-AC-18

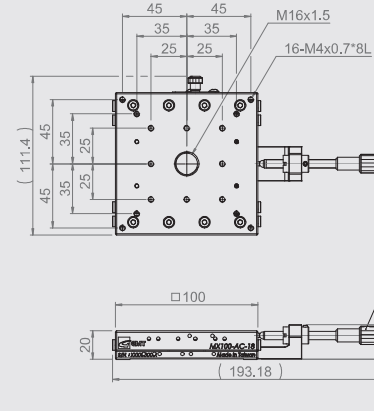

MX100-AS-18

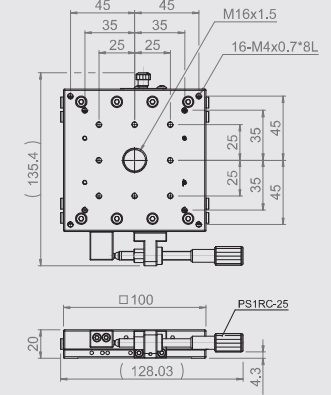

MY100-AC-18

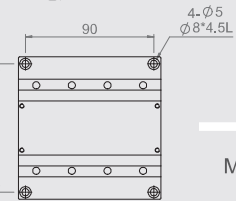
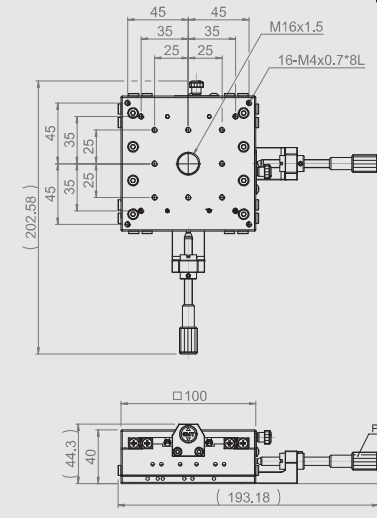

MY100-AS-18

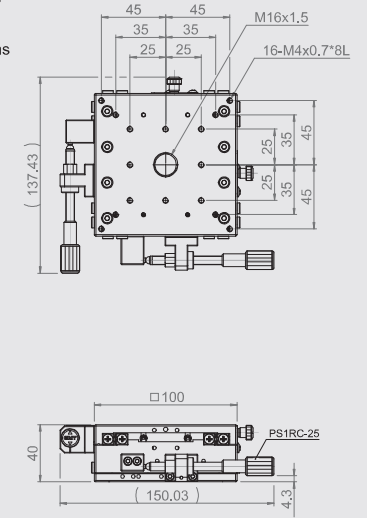

Specification

Unit : mm

Model No.	Table Size	Axis	Feed Position	Travel Stroke	Movement Per Knob Rotation (μm)	Straightness Accuracy (μm)	Allowable Loading (kgf)	Weight (kg)	Material	Surface Finish
MX100-AC-18	100*100	X-axis	Central	±12.5	50	3	15	0.7	Aluminum alloy	Black anodized
MX100-AS-18			Side							
MY100-AC-18		XY-axis	Central				14.3			
MY100-AS-18			Side							

MX120-AC-18



MX120-AS-18



MY120-AC-18



MY120-AS-18



Specification

Unit : mm

Model No.	Table Size	Axis	Feed Position	Travel Stroke	Movement Per Knob Rotation (μm)	Straightness Accuracy (μm)	Allowable Loading (kgf)	Weight (kg)	Material	Surface Finish
MX120-AC-18	120*120	X-axis	Central	±12.5	50	3	20	1.6	Aluminum alloy	Black anodized
MX120-AS-18			Side							
MY120-AC-18		XY-axis	Central				18.4	3.2		
MY120-AS-18			Side							

MX120-AC-18

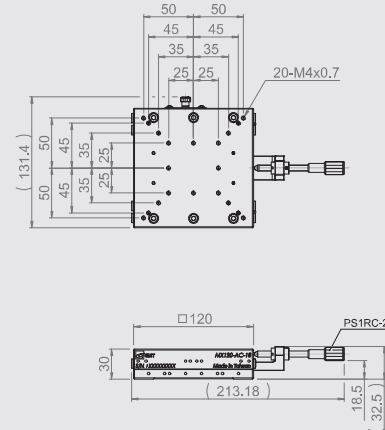

MX120-AS-18

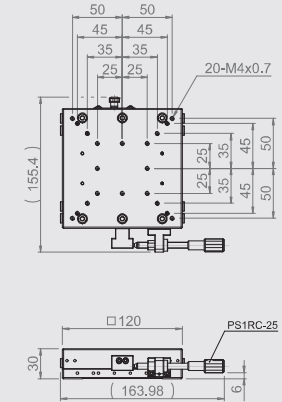

MY120-AC-18

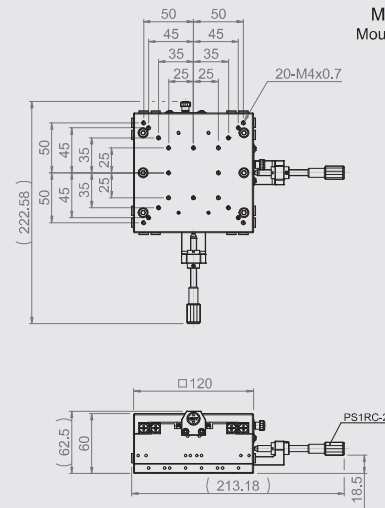

MY120-AS-18

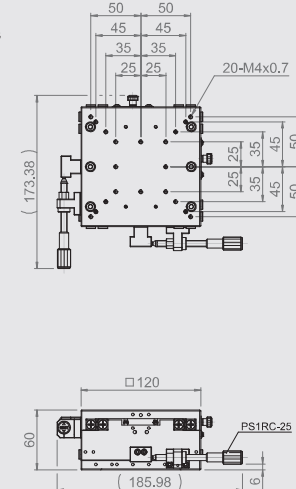

MX(Y)120-A-18
Mounting Dimensions

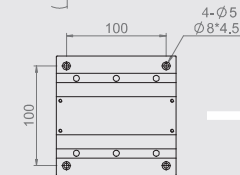

MX764-AC-SHR

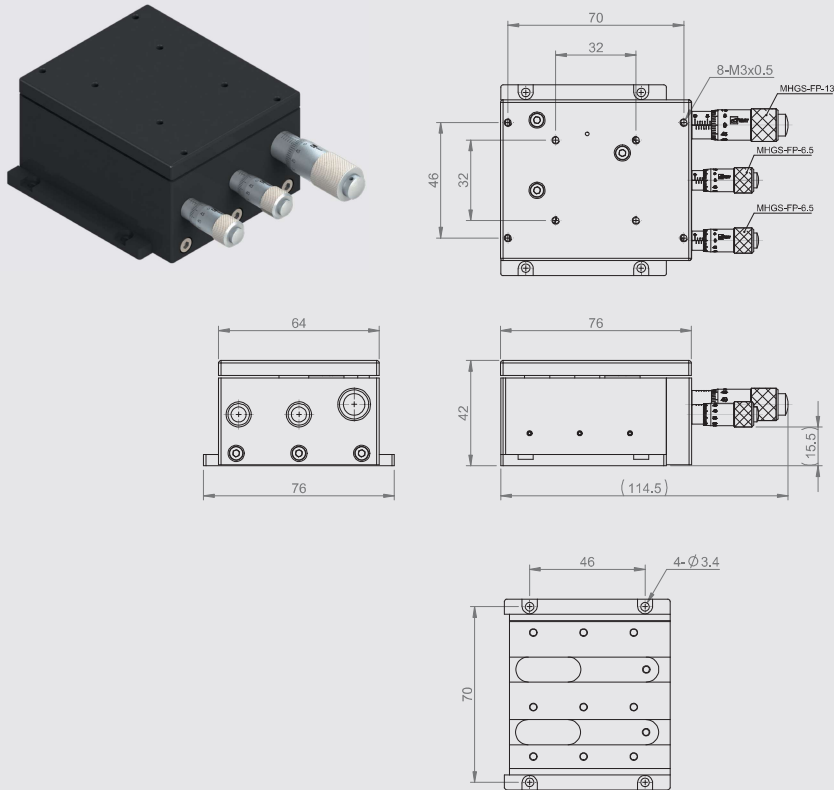

Specification

Unit : mm

Model No.	Table Size	Axis	Travel Stroke	Micrometer Minimum Reading (μm)	Straightness Accuracy (μm)	Allowable Loading (kgf)	Weight (kg)	Material	Surface Finish
MX764-AC-SHR	76*64	X-axis	Cursory : ±6.5	Cursory : 10	3	1.5	0.6	Aluminum alloy	Black anodized
			Medium : ±0.325	Medium : 1					
			Fine : ±0.0325	Fine : 0.1					

MBZ20-AML

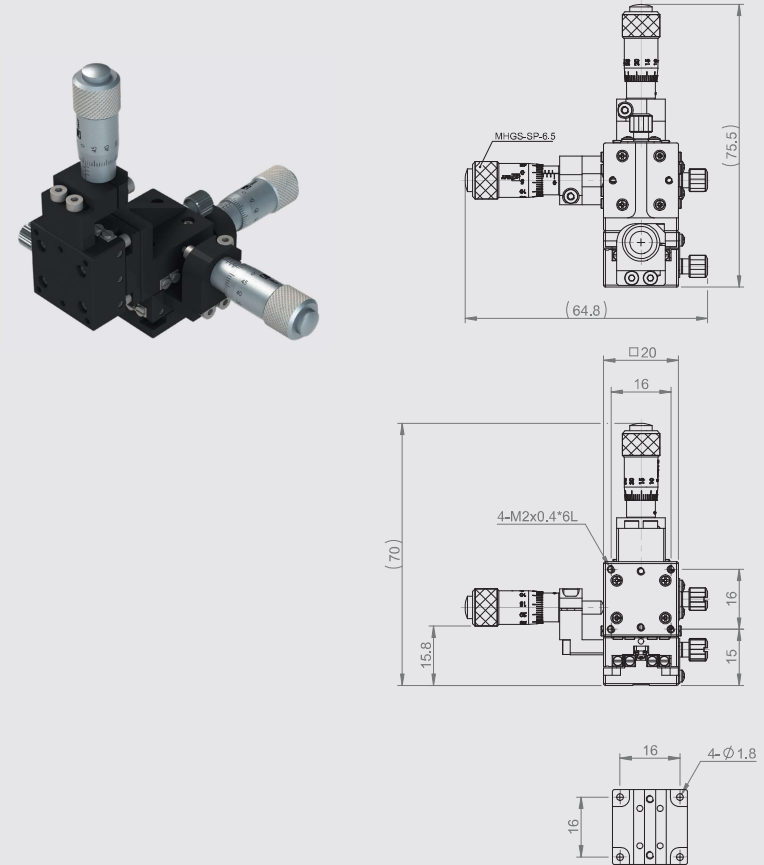

Specification

Unit : mm

Model No.	Table Size	Axis	Travel Stroke	Micrometer Minimum Reading (μm)	Straightness Accuracy (μm)	Allowable Loading (kgf)	Weight (kg)	Material	Surface Finish
MBZ20-AML(R)	20*20	XYZ-axis	±3	10	3	1	0.08	Aluminum alloy	Black anodized

※The 2D drawing shown was copied from MBZ20-AMR.

MBZ30-AML

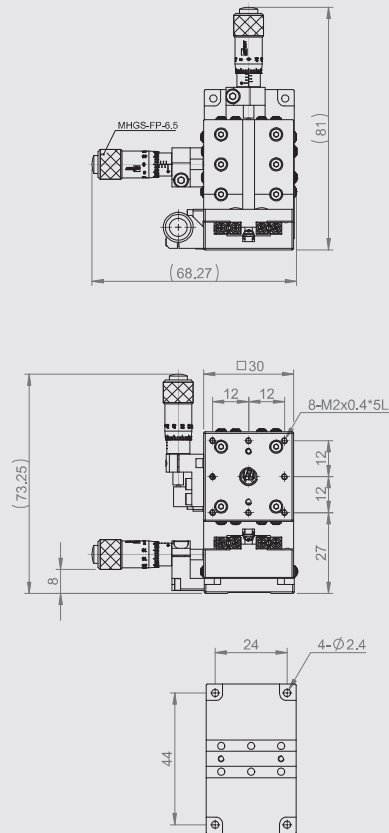
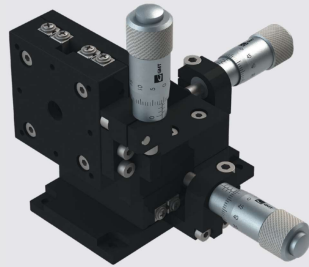

MYCP40-A

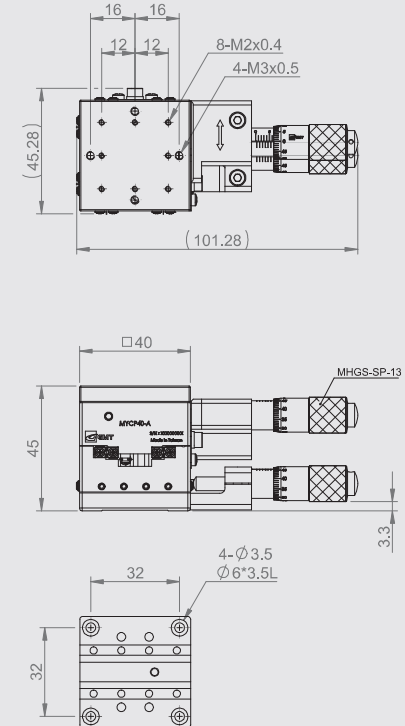

Specification

Unit : mm

Model No.	Table Size	Axis	Travel Stroke	Micrometer Minimum Reading (μm)	Straightness Accuracy (μm)	Allowable Loading (kgf)	Weight (kg)	Material	Surface Finish
MBZ30-AML (R)	30*30	XYZ-axis	±3.25	10	3	1.5	0.18	Aluminum alloy	Black anodized

※The 2D drawing shown was copied from MBZ30-AMR.

Specification

Unit : mm

Model No.	Table Size	Axis	Travel Stroke	Micrometer Minimum Reading (μm)	Straightness Accuracy (μm)	Allowable Loading (kgf)	Weight (kg)	Material	Surface Finish
MYCP40-A	40*40	XY-axis	±6.5	10	3	1.8	0.28	Aluminum alloy	Black anodized

MYCP60-A

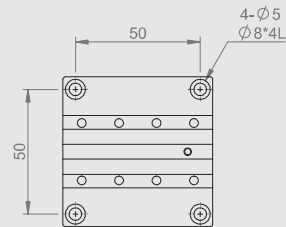
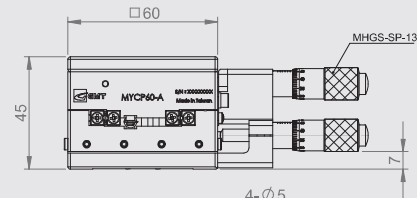
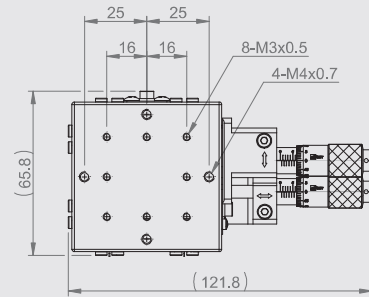
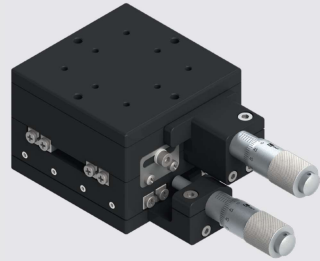

MPS20-AML-18

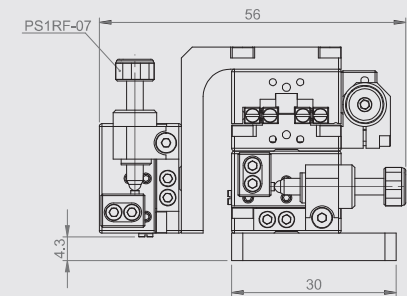
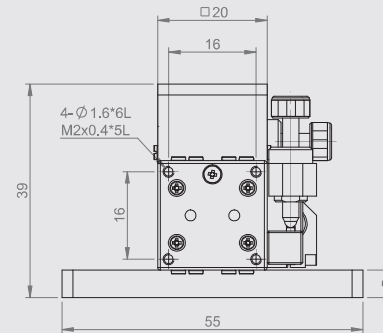
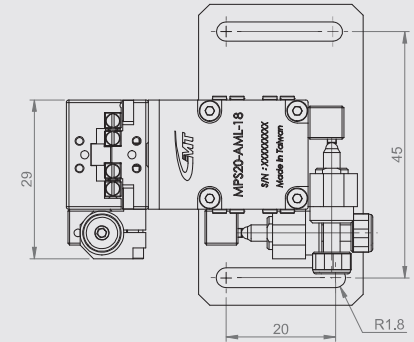
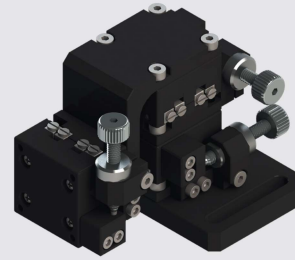

Specification

Unit : mm

Model No.	Table Size	Axis	Travel Stroke	Micrometer Minimum Reading (μm)	Straightness Accuracy (μm)	Allowable Loading (kgf)	Weight (kg)	Material	Surface Finish
MYCP60-A	60*60	XY-axis	±6.5	10	3	4.5	0.5	Aluminum alloy	Black anodized

Specification

Unit : mm

Model No.	Table Size	Axis	Travel Stroke	Movement Per Knob Rotation	Straightness Accuracy (μm)	Allowable Loading (kgf)	Weight (kg)	Material	Surface Finish
MPS20-AMR(L)-18	20*20	XYZ-axis	±3	0.5	3	1	0.11	Aluminum alloy	Black anodized

MPS2035-AML

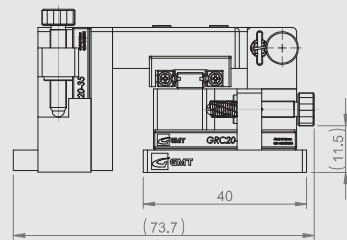
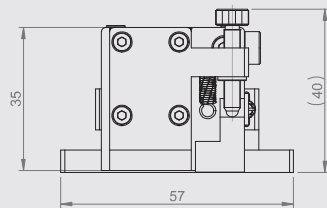
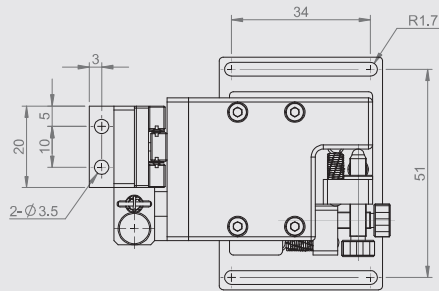
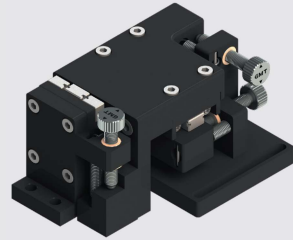

MPS40-SML

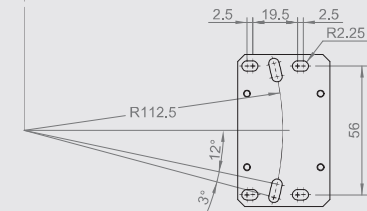
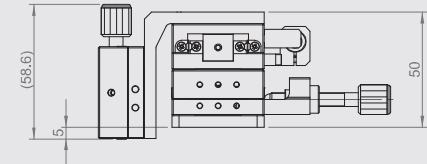
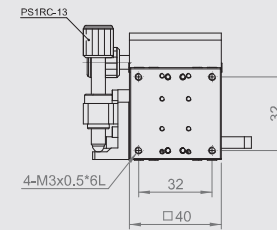
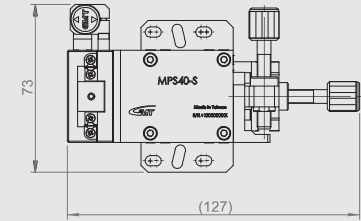
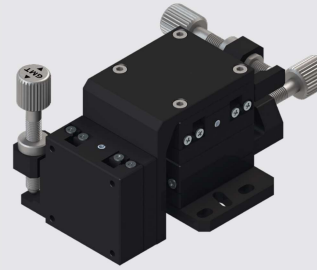

Specification

Unit : mm

Model No.	Table Size	Axis	Travel Stroke	Movement Per Knob Rotation	Minimum Reading (μm)	Straightness Accuracy (μm)	Allowable Loading (kgf)	Weight (kg)	Material	Surface Finish
MPS2035-AMR(L)	20*35	XYZ-axis	±5	0.25	10	3	1.5	0.21	Aluminum alloy	Black anodized

Specification

Unit : mm

Model No.	Table Size	Axis	Travel Stroke	Movement Per Knob Rotation	Minimum Reading (μm)	Straightness Accuracy (μm)	Allowable Loading (kgf)	Weight (kg)	Material	Surface Finish
MPS40-SMR(L)	40*40	XYZ-axis	±6.5	0.5	10	3	4.5	0.99	SUS440C	Black Chromium

MXTH80-FCS

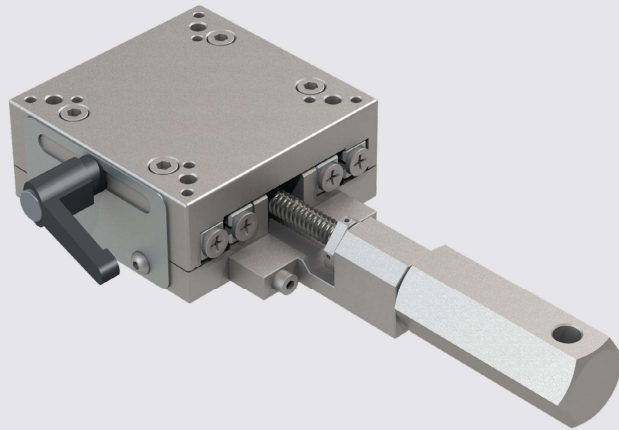

MXTH80-FCS

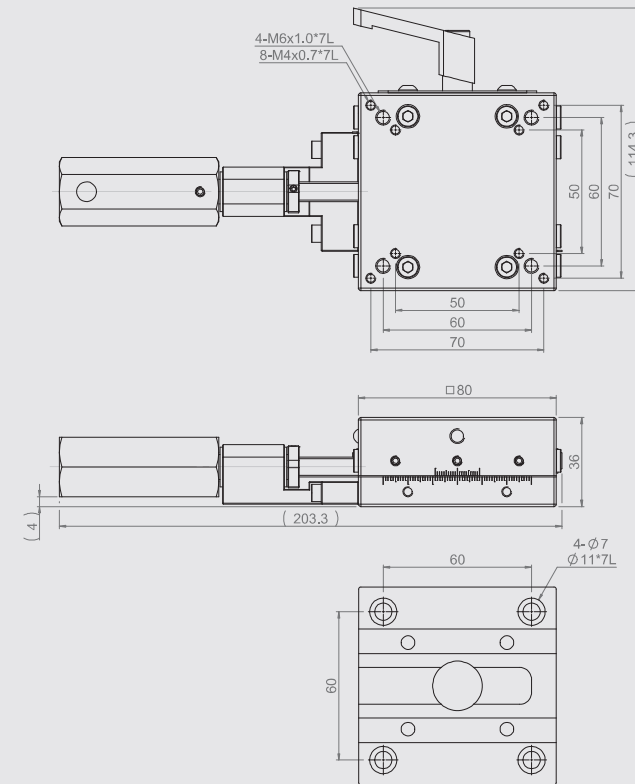

Specification

Unit : mm

Model No.	Table Size	Axis	Feed Position	Travel Stroke	Movement Per Knob Rotation	Minimum Reading	Straightness Accuracy (μm)	Allowable Loading (kgf)	Weight (kg)	Material	Surface Finish
MXTH80-FCS	80*80	X-axis	Central	±20	1.25	0.1 mm / Vernier	15	40.5	1.9	Carbon steel	Electroless nickel plating

MX25-SC

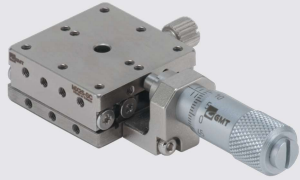

MX25-SS

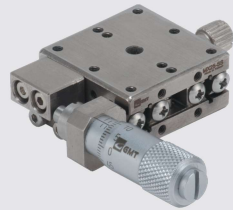

MY25-SC

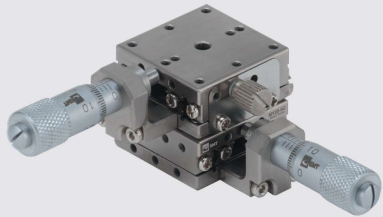

MY25-SS

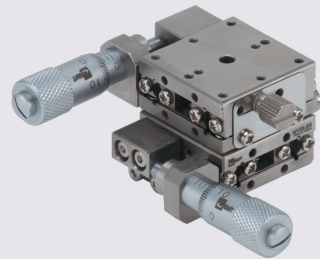

Specification

Unit : mm

Model No.	Table Size	Axis	Feed Position	Travel Stroke	Micrometer Minimum Reading (μm)	Straightness Accuracy (μm)	Allowable Loading (kgf)	Weight (kg)	Material	Surface Finish	
MX25-SC	25*25	X-axis	Central	±3.2	10	3	4	0.07	SUS 440C	Electroless nickel plating	
MX25-SS			Side								
MY25-SC		XY-axis	Central				3.9				0.14
MY25-SS			Side								

MX25-SC

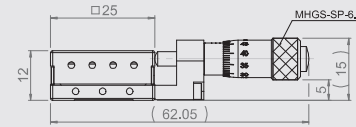
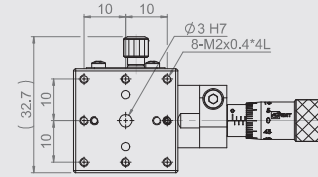

MX25-SS

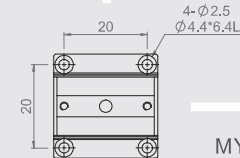
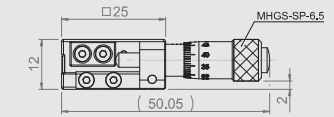
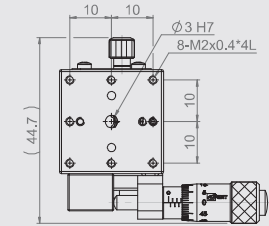

MY25-SC

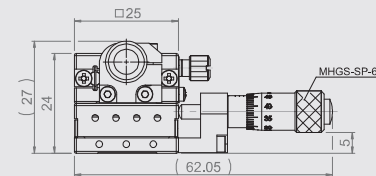
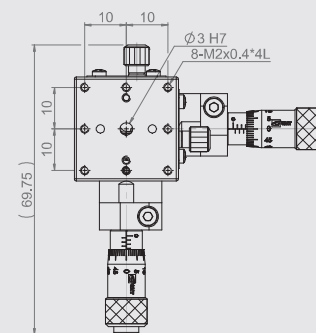

MY25-SS

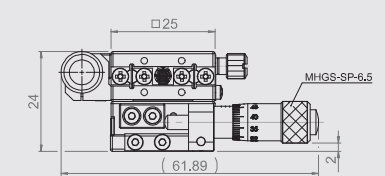
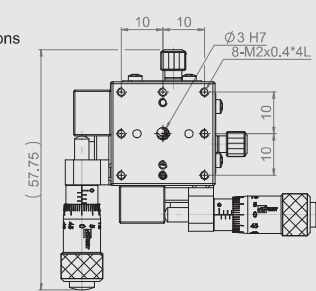

MX30-SC



MX30-SS



MY30-SC



MY30-SS



Specification

Unit : mm

Model No.	Table Size	Axis	Feed Position	Travel Stroke	Micrometer Minimum Reading (μm)	Straightness Accuracy (μm)	Allowable Loading (kgf)	Weight (kg)	Material	Surface Finish
MX30-SC	30*30	X-axis	Central	±3.2	10	3	6	0.08	SUS 440C	Electroless nickel plating
MX30-SS			Side							
MY30-SC		XY-axis	Central				5.9	1.9		
MY30-SS			Side							

MX30-SC

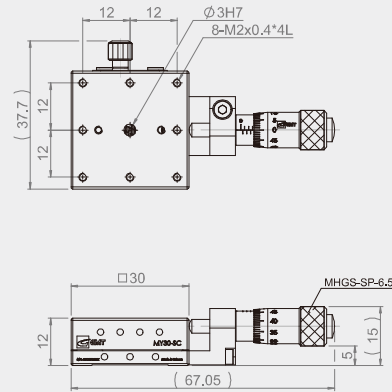

MX30-SS

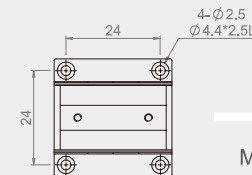
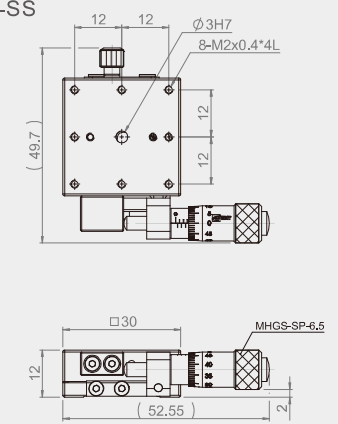

MX(Y)30-S
Mounting Dimensions

MY30-SC

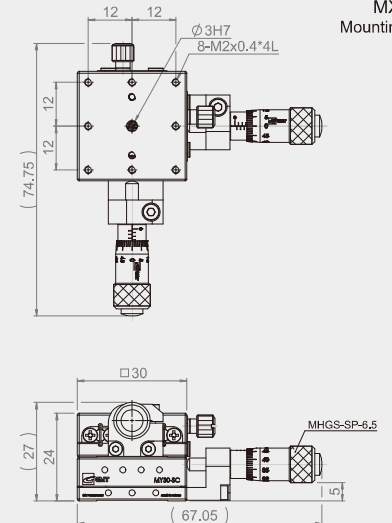

MY30-SS

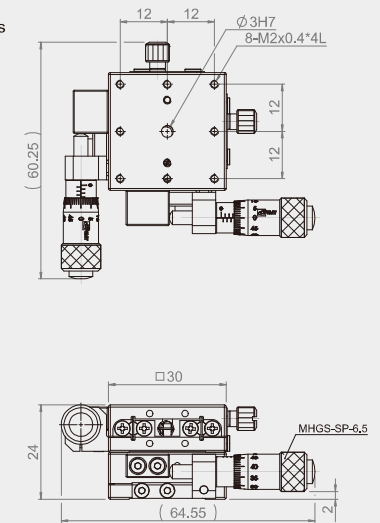

MX40-SC



MX40-SS



MY40-SC



MY40-SS



Specification

Unit : mm

Model No.	Table Size	Axis	Feed Position	Travel Stroke	Micrometer Minimum Reading (μm)	Straightness Accuracy (μm)	Allowable Loading (kgf)	Weight (kg)	Material	Surface Finish	
MX40-SC	40*40	X-axis	Central	±6.5	10	3	10	0.23	SUS 440C	Electroless nickel plating	
MX40-SS			Side								
MY40-SC		XY-axis	Central				9.7				0.46
MY40-SS			Side								

MX40-SC

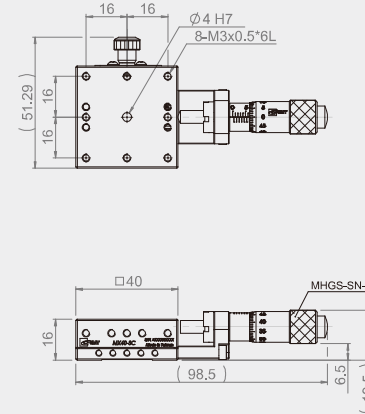

MX40-SS

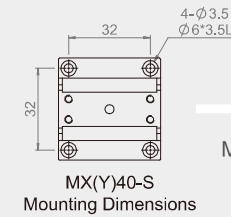
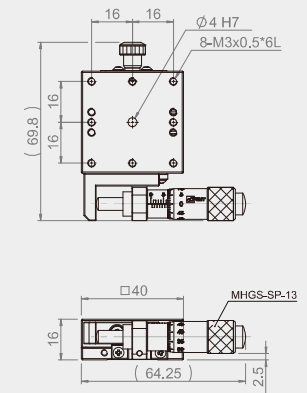

MY40-SC

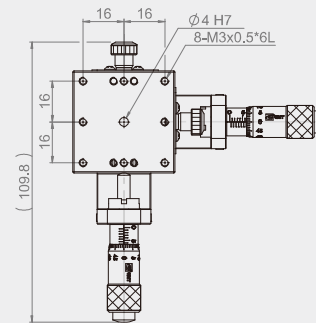

MY40-SS

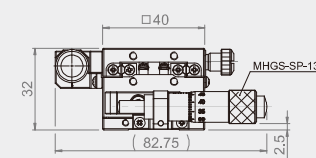
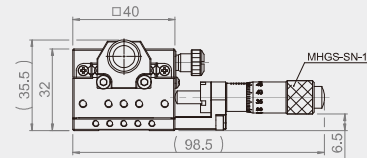
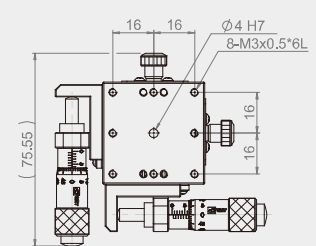

MX50-SC



MX50-SS



MY50-SC



MY50-SS



Specification

Unit : mm

Model No.	Table Size	Axis	Feed Position	Travel Stroke	Micrometer Minimum Reading (μm)	Straightness Accuracy (μm)	Allowable Loading (kgf)	Weight (kg)	Material	Surface Finish
MX50-SC	50*50	X-axis	Central	±6.5	10	3	15	0.28	SUS 440C	Electroless nickel plating
MX50-SS			Side							
MY50-SC		XY-axis	Central							
			MY50-SS				Side			

MX50-SC

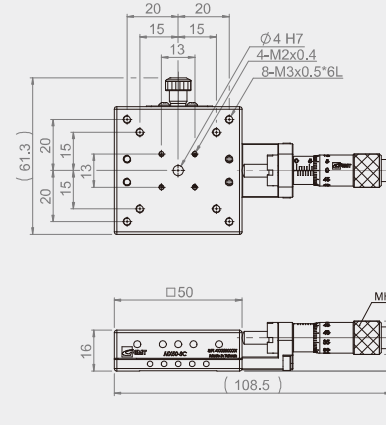

MX50-SS

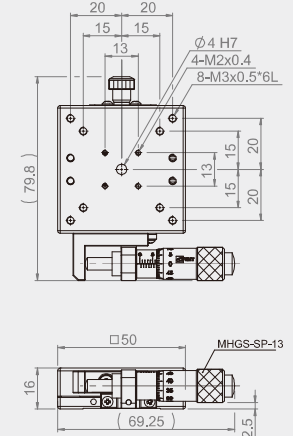

MY50-SC

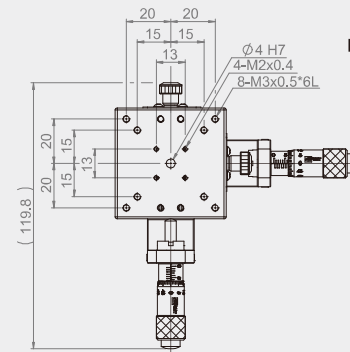

MY50-SS

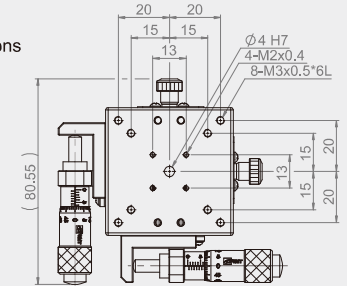

MX(Y)50-S Mounting Dimensions

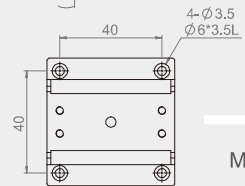

MX60-SC



MX60-SS



MY60-SC



MY60-SS



Specification

Unit : mm

Model No.	Table Size	Axis	Feed Position	Travel Stroke	Micrometer Minimum Reading (μm)	Straightness Accuracy (μm)	Allowable Loading (kgf)	Weight (kg)	Material	Surface Finish
MX60-SC	60*60	X-axis	Central	±6.5	10	3	20	0.4	SUS 440C	Electroless nickel plating
MX60-SS			Side							
MY60-SC		XY-axis	Central				19.6			
MY60-SS			Side							

MX60-SC

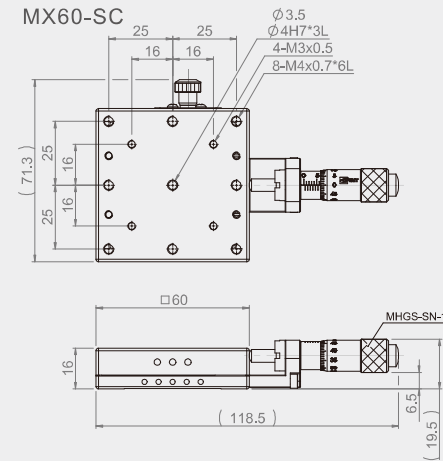

MX60-SS

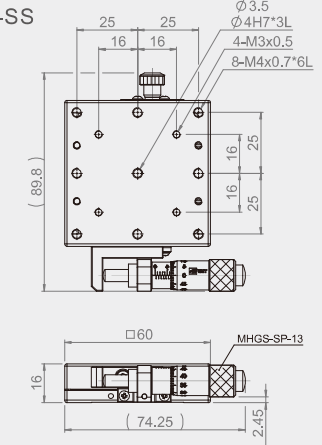

MY60-SC

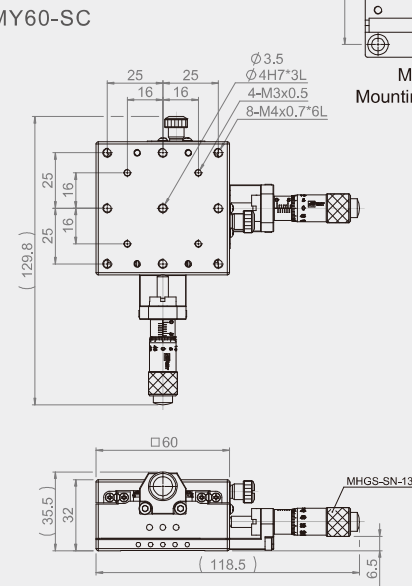

MY60-SS

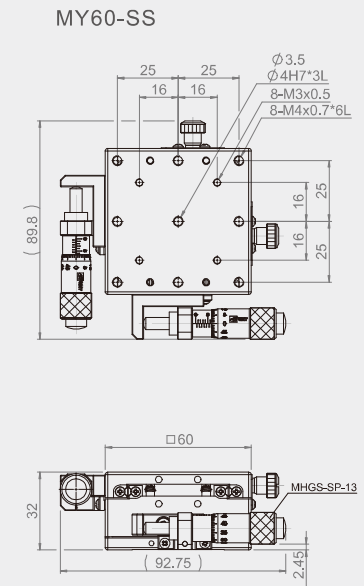

MX(Y)60-S
Mounting Dimensions

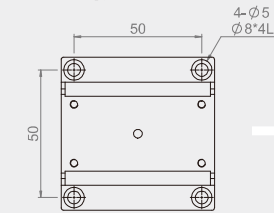

MX70-SC



MX70-SS



MY70-SC



MY70-SS



Specification

Unit : mm

Model No.	Table Size	Axis	Feed Position	Travel Stroke	Micrometer Minimum Reading (μm)	Straightness Accuracy (μm)	Allowable Loading (kgf)	Weight (kg)	Material	Surface Finish
MX70-SC	70*70	X-axis	Central	±6.5	10	3	23	0.58	SUS 440C	Electroless nickel plating
MX70-SS			Side							
MY70-SC		XY-axis	Central				22.4			
MY70-SS			Side							

MX70-SC

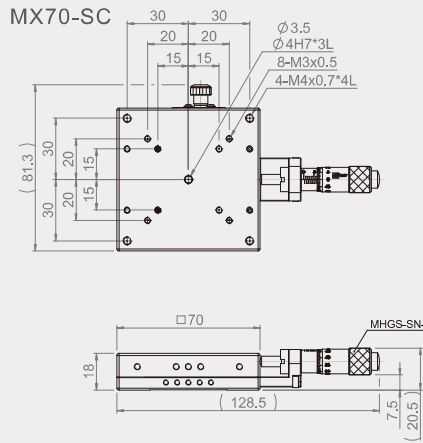

MX70-SS

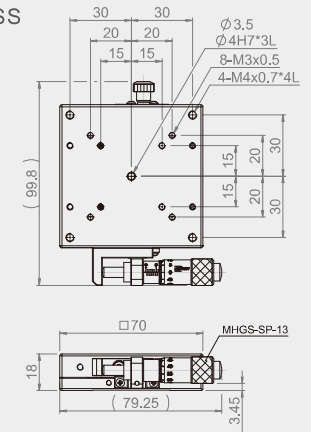

MY70-SC

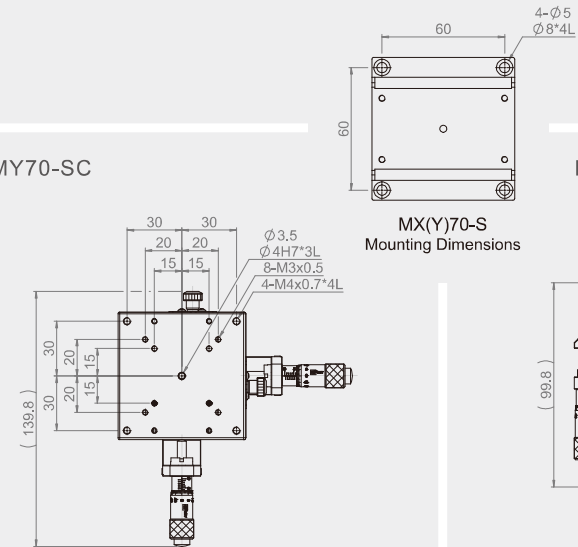

MY70-SS

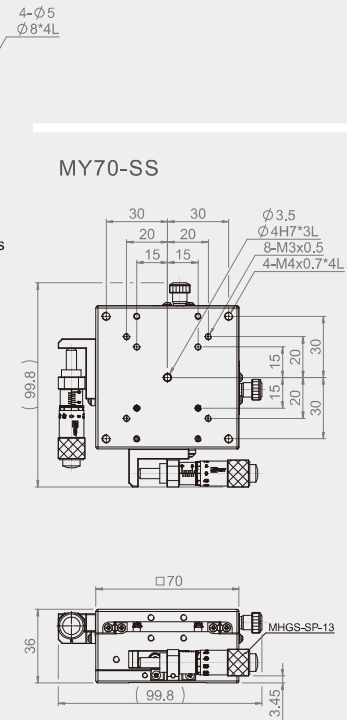

MX(Y)70-S
Mounting Dimensions

MX80-SC



MX80-SS

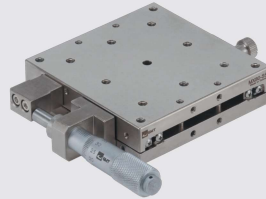

MY80-SC



MY80-SS

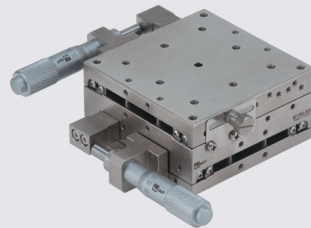

Specification

Unit : mm

Model No.	Table Size	Axis	Feed Position	Travel Stroke	Micrometer Minimum Reading (μm)	Straightness Accuracy (μm)	Allowable Loading (kgf)	Weight (kg)	Material	Surface Finish
MX80-SC	80*80	X-axis	Central	±12.5	10	3	27	0.9	SUS 440C	Electroless nickel plating
MX80-SS			Side							
MY80-SC		XY-axis	Central				26.1	1.8		
MY80-SS			Side							

MX80-SC

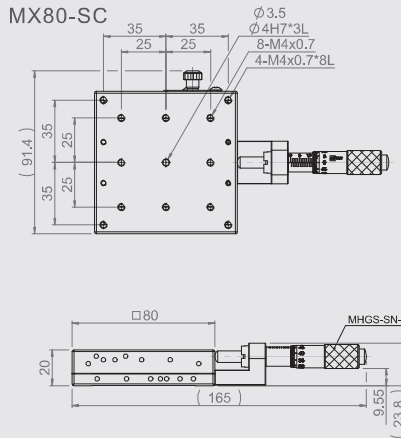

MX80-SS

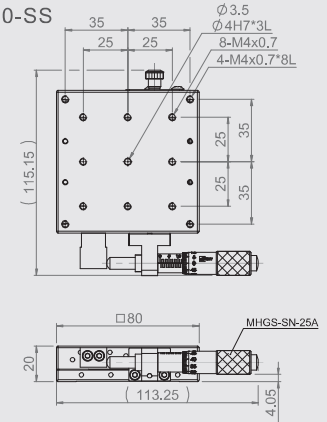

MY80-SC

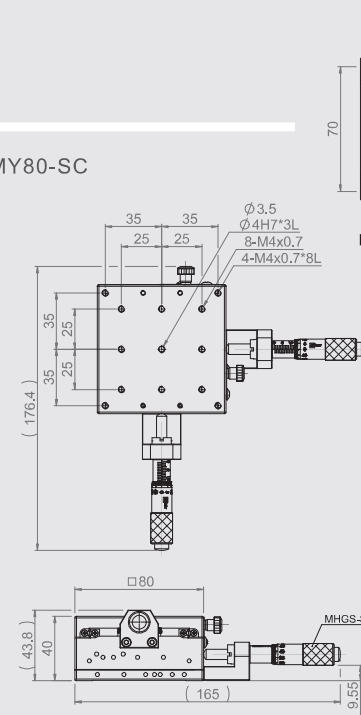

MY80-SS

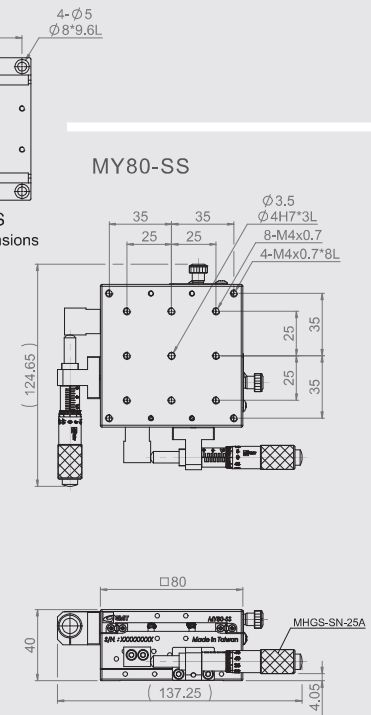

MX(Y)80-S
Mounting Dimensions

MX100-SC

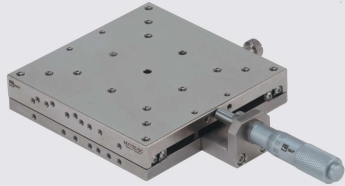

MX100-SS

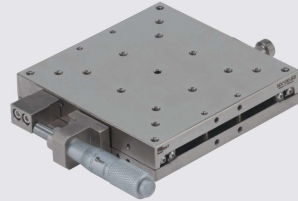

MY100-SC



MY100-SS

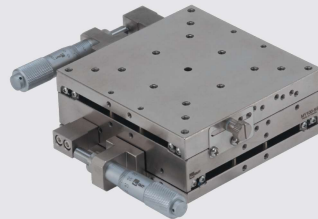

Specification

Unit : mm

Model No.	Table Size	Axis	Feed Position	Travel Stroke	Micrometer Minimum Reading (μm)	Straightness Accuracy (μm)	Allowable Loading (kgf)	Weight (kg)	Material	Surface Finish	
MX100-SC	100*100	X-axis	Central	±12.5	10	3	35	1.33	SUS 440C	Electroless nickel plating	
MX100-SS			Side								
MY100-SC		XY-axis	Central				33.6				2.66
MY100-SS			Side								

MX100-SC

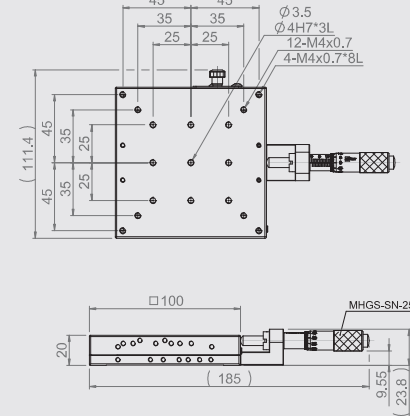

MX100-SS

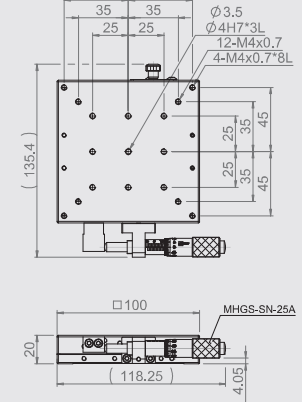

MY100-SC

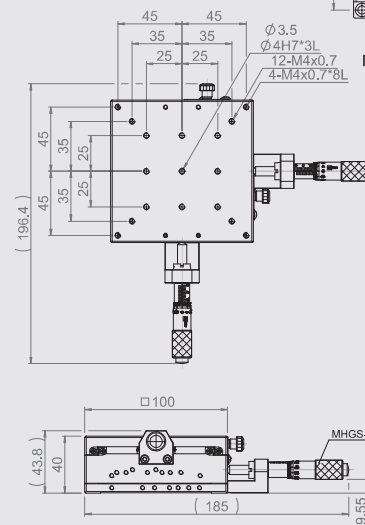

MY100-SS

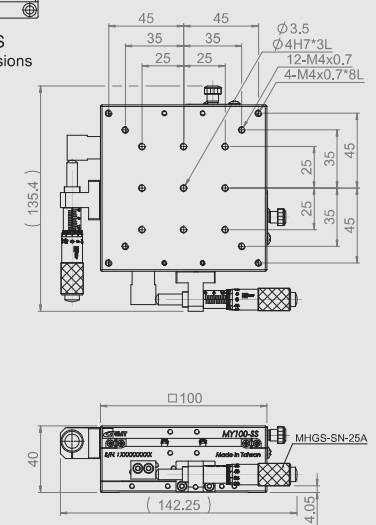

MX(Y)100-S
Mounting Dimensions

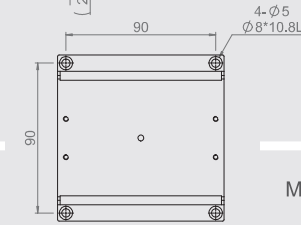

MZL60-SCR

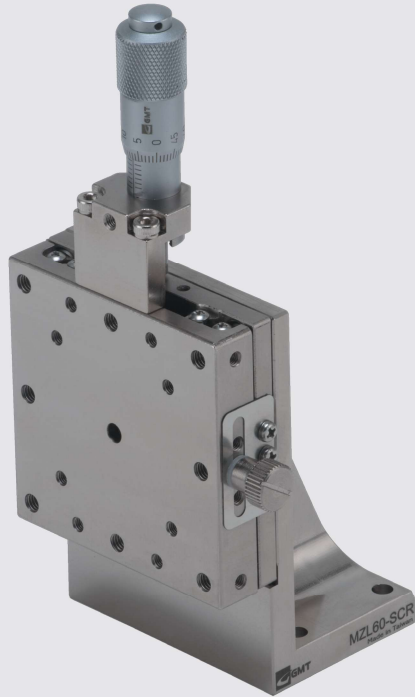

MZL25-SCR

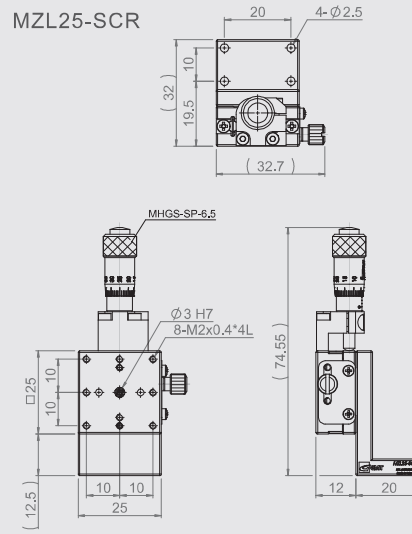

MZL40-SCR

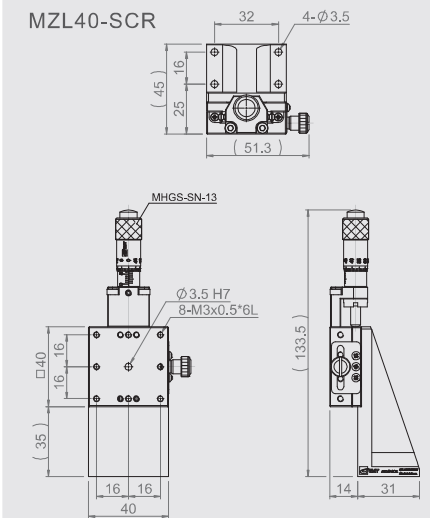

MZL60-SCR

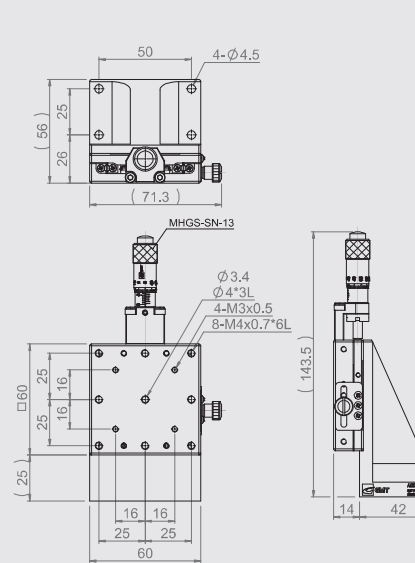

MZL80-SCR

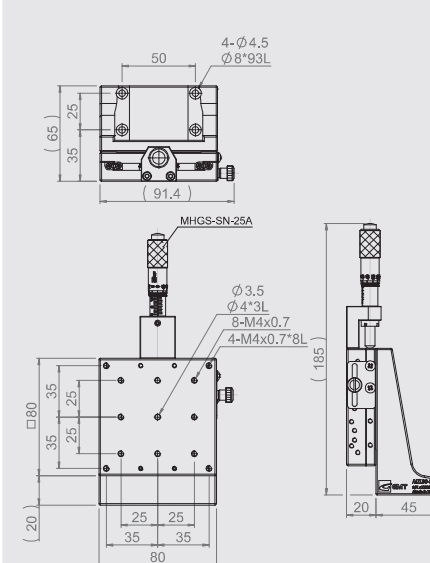

Specification

Unit : mm

Model No.	Table Size	Travel Distance	Micrometer Minimum Reading (μm)	Movement Accuracy			Allowable Loading (kgf)	Weight (kg)	Material	Surface Finish
				Straightness (μm)	Pitching	Yawing				
MZL25-SCR	25*25	±3.2	10	3	30"	25"	1	0.23	SUS 440C	Electroless nickel plating
MZL40-SCR	40*40	±6.5			25"	15"	5	0.32		
MZL60-SCR	60*60				5	0.58				
MZL80-SCR	80*80				1.2					

★ Brackets for Z-axis, refer to P.0195- P.0196

MZL25-SS



MZL40-SS



MZL60-SS

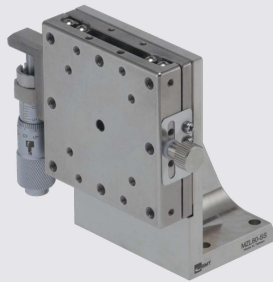

MZL80-SS



Specification

Unit : mm

Model No.	Table Size	Travel Distance	Micrometer Minimum Reading (μm)	Movement Accuracy			Allowable Loading (kgf)	Weight (kg)	Material	Surface Finish
				Straightness (μm)	Pitching	Yawing				
MZL25-SS	25*25	±3.2	10	3	30"	25"	1.0	0.09	SUS 440C	Electroless nickel plating
MZL40-SS	40*40	±6.5			25"	15"				
MZL60-SS	60*60	±12.5								
MZL80-SS	80*80									

★ Brackets for Z-axis, refer to P.0195 - P.0196

MZL25-SS

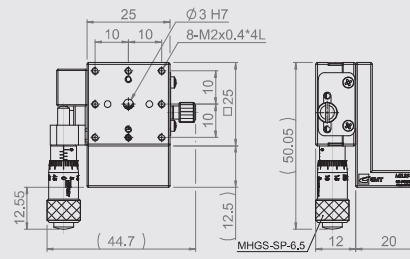
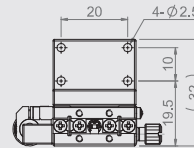

MZL40-SS

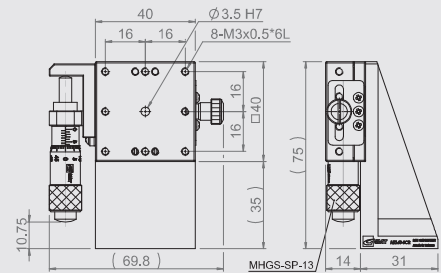
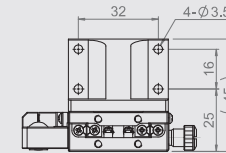

MZL60-SS

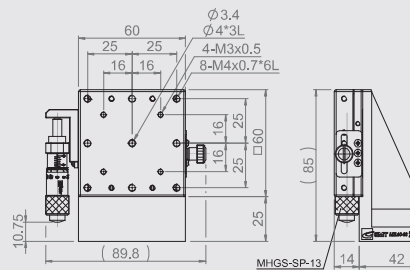
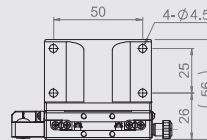

MZL80-SS

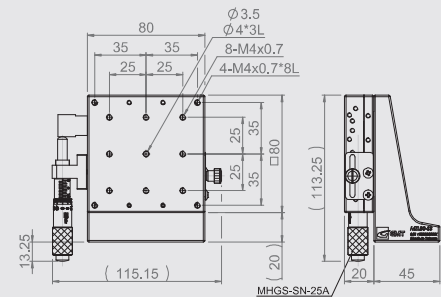
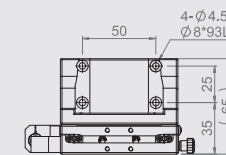

MYW40-SC

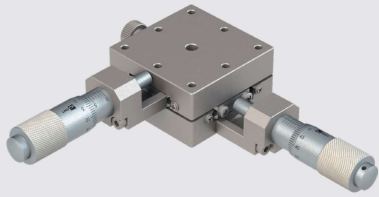

MYW60-SC

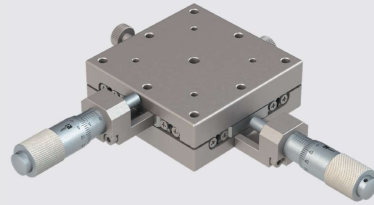

MYW80-SC

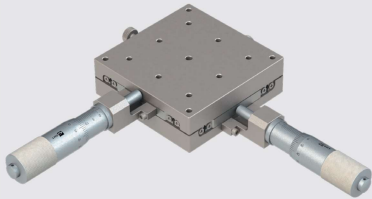

MYW100-SC

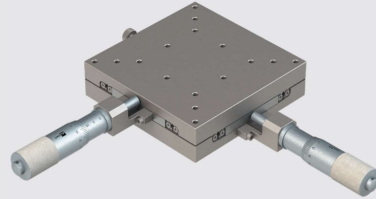

Specification

Unit : mm

Model No.	Table Size	Axis	Feed Position	Travel Stroke	Micrometer Minimum Reading (μm)	Straightness Accuracy (μm)	Allowable Loading (kgf)	Weight (kg)	Material	Surface Finish
MYW40-SC	40*40	XY-axis	Central	±6.5	10	3	9	0.34	SUS 440C	Electroless nickel plating
MYW60-SC	60*60						19	0.64		
MYW80-SC	80*80			±12.5			20	1.32		
MYW100-SC	100*100						25	2		

MYW40-SC

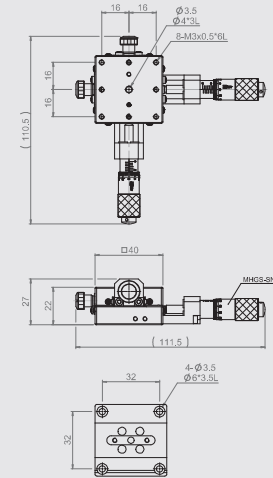

MYW60-SC

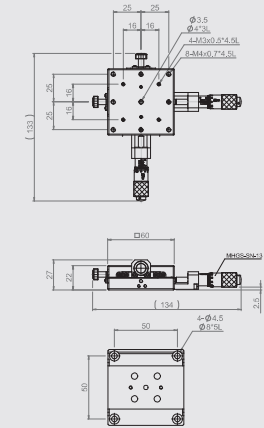

MYW80-SC

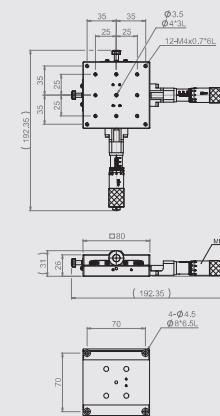

MYW100-SC

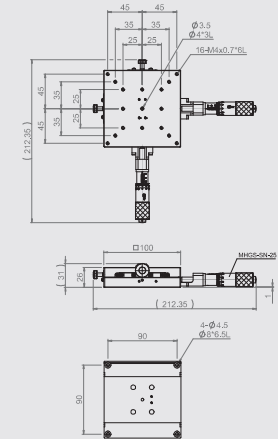

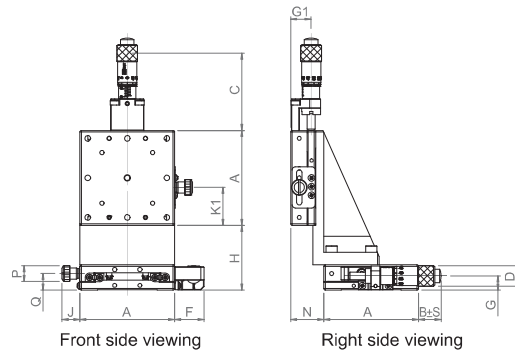

Unit : mm

Position of Micrometer

	Side up	Side down	Central	Reversed
Specification				
Code	C	CU	A	R

Specification

Unit : mm

Model No.	Detailed Dimension from Front Side Viewing								Detailed Dimensions from Right Side Viewing				
	A	H	C	K1	P	Q	J	F	B ± S (Movement)	N	D	G	G1
MXZ	25	24.5	37.1	15	6	8.5	7.7	11	25±3.2	6.8	10	7	10
	30	32	37.1	17.5	6	8.5	7.7	11	22.5±3.2	5	10	7	10
	40	51	58.5	20	10	10.6	11.2	18.5	24.3±6.5	5	13	8.9	13
	50	46	58.5	25	10	10.5	11.2	18.5	19.3±6.5	20	13	9	13
	60	41	58.5	24	10	10.5	11.2	18.5	14.3±6.5	21	13	8.9	13
	70	43	58.5	29	10	11.5	11.2	18.5	9.3±6.5	12	13	10	14
	80	40	85	55	10	14.5	11.2	24	33.3±12.5	20	13.5	10.8	16
	100	60	99.5	67.5	10	14.5	11.2	24	18.3±12.5	36	13.5	10.8	16

Model No.	Table Size	Allowable Loading (kgf)	Straightness Accuracy (μm)	Pitching	Yawing	Axis	Weight (kg)	Material	Surface Finish
MXZ25-S	25*25	5	5	30"	25"	XZ	0.15	SUS 440C	Electroless nickel plating
MXZ30-S	30*30						0.21		
MXZ40-S	40*40						0.51		
MXZ50-S	50*50						0.76		
MXZ60-S	60*60						0.98		
MXZ70-S	70*70						1.44		
MXZ80-S	80*80						2.05		
MXZ100-S	100*100						3.63		

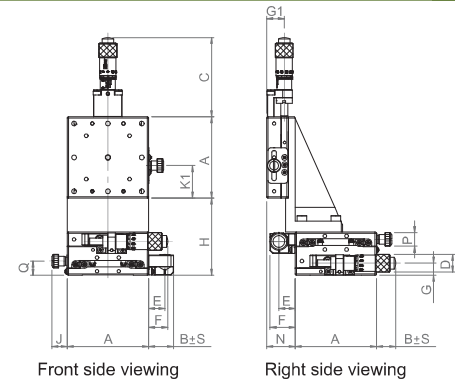

Unit : mm

Position of Micrometer

	Side up	Side down	Central	Reversed
Specification				
Code	C	CU	A	R

Specification

Unit : mm

Model No.	Detailed Dimension from Front Side Viewing								Detailed Dimensions from Right Side Viewing					
	A	H	C	K1	Q	J	F	E	B ± S (Movement)	N	D	G	G1	P
MXYZ	25	36.5	37.1	15	8.5	7.7	11	6.8	25.1±3.2	16.8	10	7	10	6
	30	44	37	17.5	8.5	7.7	11	7	22.6±3.2	17	10	7	10	6
	40	67	58.5	20	10.6	11.2	18.5	12	24.3±6.5	21	13	9	13	10
	50	62	58.5	25	10.6	11.2	18.5	12	19.3±6.5	20	13	9	13	10
	60	57	58.5	24	10.5	11.2	18.5	12	14.3±6.5	21	13	9	13	10
	70	61	58.5	29	11.5	11.2	18.5	12	9.3±6.5	12	13	10	14	10
	80	60	85	55	14.5	11.2	24	17	33.3±12.5	20	13.5	10.8	16	10
	100	80	99.5	67.5	14.5	11.2	24	17	18.3±12.5	36	13.5	10.8	16	10

Model No.	Table Size	Allowable Loading (kgf)	Straightness Accuracy (μm)	Pitching	Yawing	Axis	Weight (kg)	Material	Surface Finish
MXYZ25-S	25*25	5	5	30"	25"	XYZ	0.21	SUS 440C	Electroless nickel plating
MXYZ30-S	30*30						0.29		
MXYZ40-S	40*40						0.72		
MXYZ50-S	50*50						1.06		
MXYZ60-S	60*60						1.38		
MXYZ70-S	70*70						2.06		
MXYZ80-S	80*80						2.96		
MXYZ100-S	100*100						4.99		

MX25-SC-28

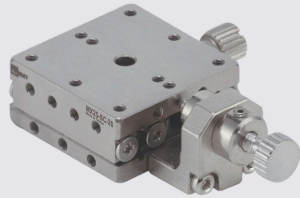

MX25-SS-28

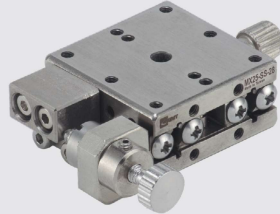

MY25-SC-28



MY25-SS-28

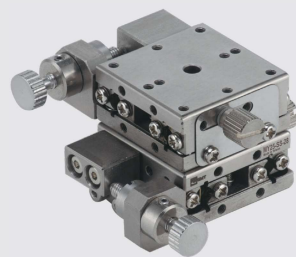

Specification

Unit : mm

Model No.	Table Size	Axis	Feed Position	Travel Stroke	Movement Per Knob Rotation (mm)	Straightness Accuracy (μm)	Allowable Loading (kgf)	Weight (kg)	Material	Surface Finish
MX25-SC-28	25*25	X-axis	Central	±3.2	0.5	3	4	0.07	SUS 440C	Electroless nickel plating
MX25-SS-28			Side							
MY25-SC-28		XY-axis	Central				3.9	0.14		
MY25-SS-28			Side							

MX25-SC-28

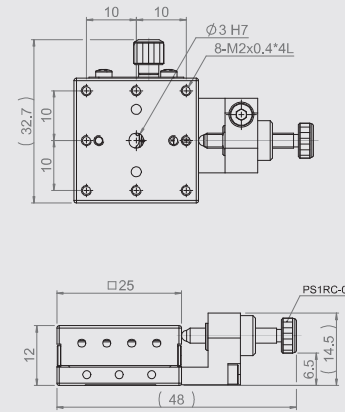

MX25-SS-28

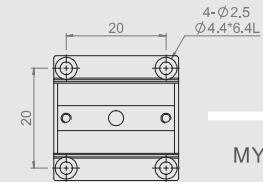
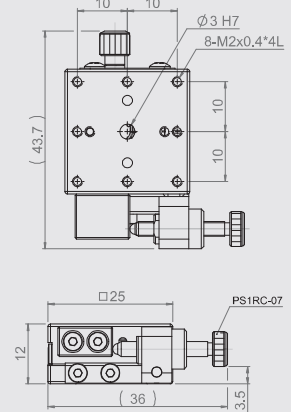

MY25-SC-28

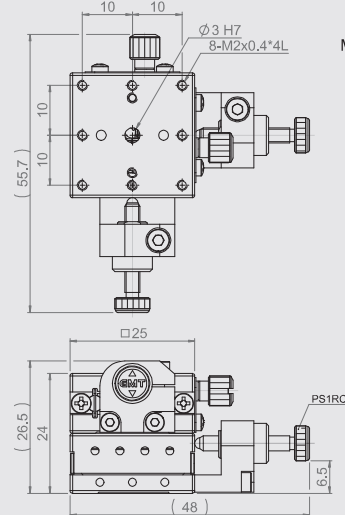

MY25-SS-28

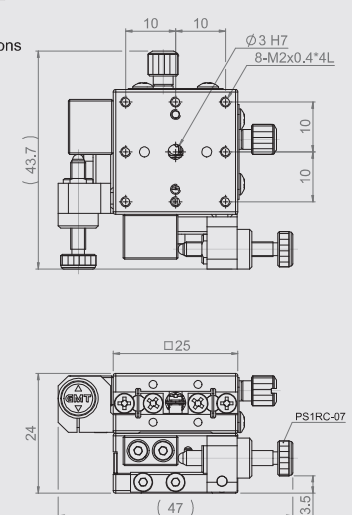

MX30-SC-28

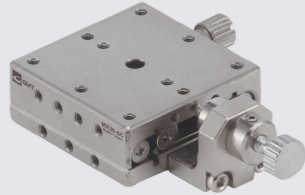

MX30-SS-28

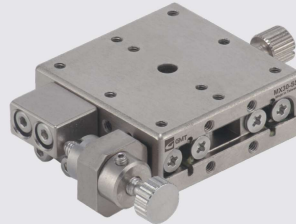

MY30-SC-28

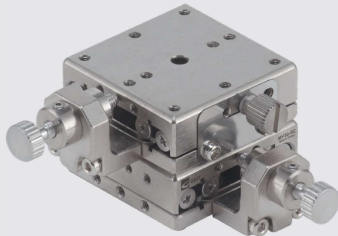

MY30-SS-28

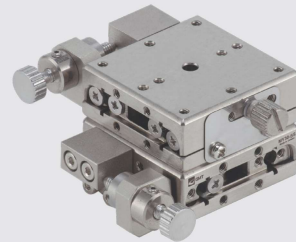

Specification

Unit : mm

Model No.	Table Size	Axis	Feed Position	Travel Stroke	Movement Per Knob Rotation (mm)	Straightness Accuracy (μm)	Allowable Loading (kgf)	Weight (kg)	Material	Surface Finish
MX30-SC-28	30*30	X-axis	Central	±3.2	0.5	3	6	0.95	SUS 440C	Electroless nickel plating
MX30-SS-28			Side							
MY30-SC-28		XY-axis	Central							
			MY30-SS-28				Side			

MX30-SC-28

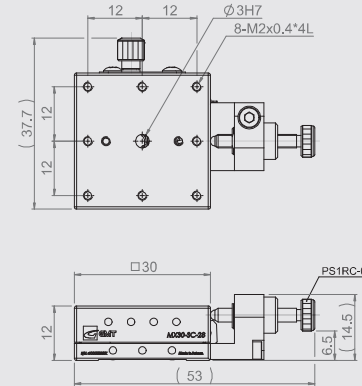

MX30-SS-28

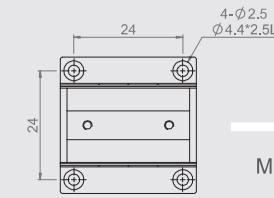
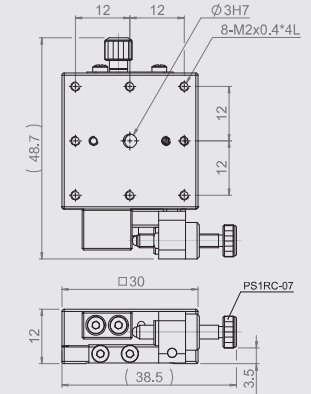

MX(Y)30-S-28
Mounting Dimensions

MY30-SC-28

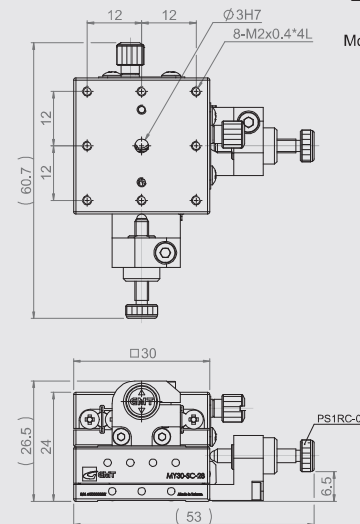

MY30-SS-28

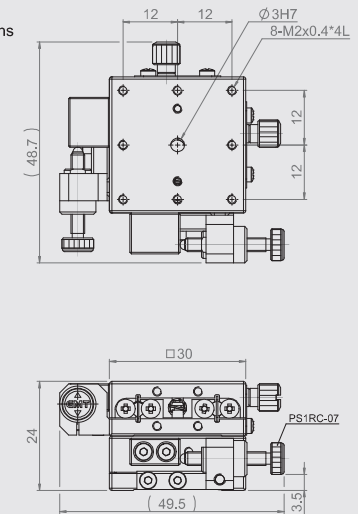

MX60-SC-28



MX60-SS-28



MY60-SC-28



MY60-SS-28



Specification

Unit : mm

Model No.	Table Size	Axis	Feed Position	Travel Stroke	Movement Per Knob Rotation (mm)	Straightness Accuracy (μm)	Allowable Loading (kgf)	Weight (kg)	Material	Surface Finish
MX60-SC-28	60*60	X-axis	Central	±6.5	0.5	5	20	0.4	SUS 440C	Electroless nickel plating
MX60-SS-28			Side							
MY60-SC-28		XY-axis	Central				19.6	0.8		
MY60-SS-28			Side							

MX60-SC-28

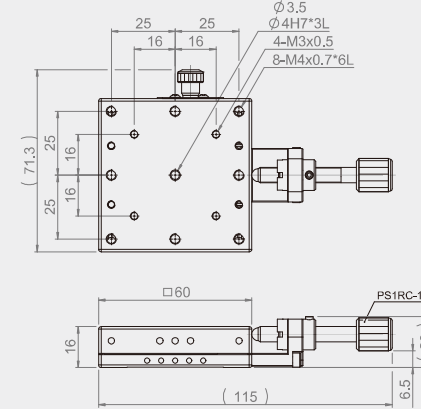

MX60-SS-28

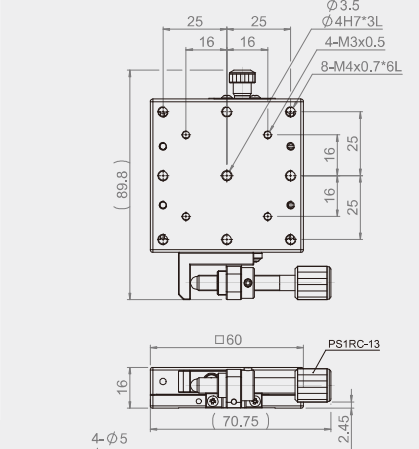

MY60-SC-28

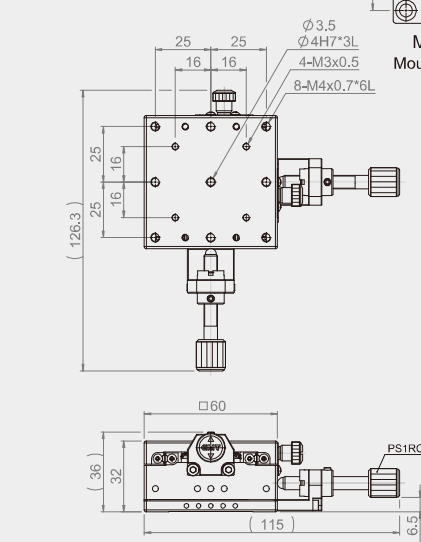

MY60-SS-28

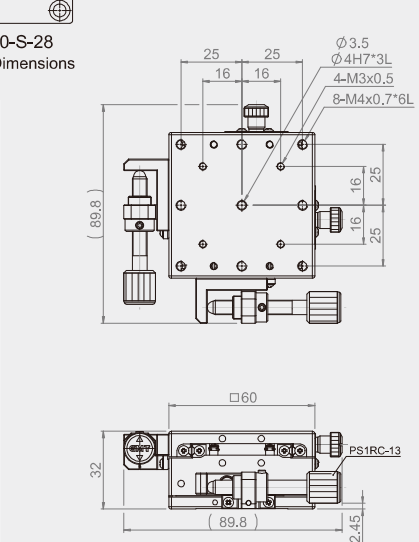

MX(Y)60-S-28
Mounting Dimensions

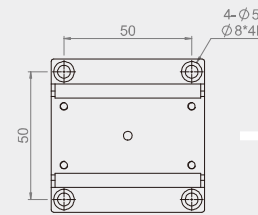

MX80-SC-28



MX80-SS-28



MY80-SC-28



MY80-SS-28

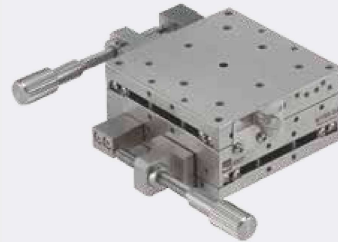

Specification

Unit : mm

Model No.	Table Size	Axis	Feed Position	Travel Stroke	Movement Per Knob Rotation (mm)	Straightness Accuracy (μm)	Allowable Loading (kgf)	Weight (kg)	Material	Surface Finish
MX80-SC-28	80*80	X-axis	Central	±12.5	0.5	3	27	0.9	SUS 440C	Electroless nickel plating
MX80-SS-28			Side							
MY80-SC-28		XY-axis	Central				26.1	1.8		
MY80-SS-28			Side							

MX80-SC-28

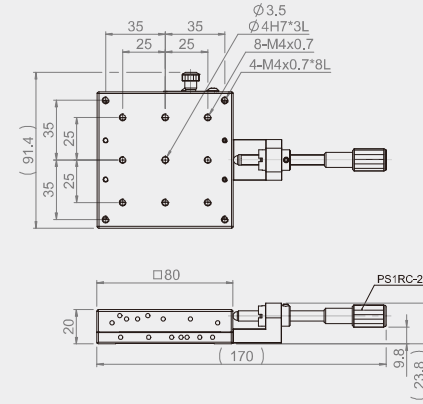

MX80-SS-28

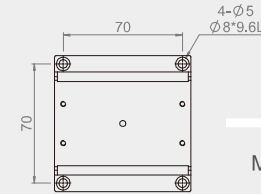
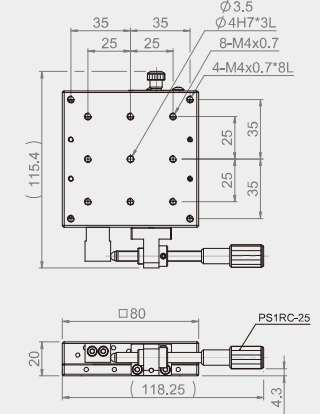

MX(Y)80-S-28
Mounting Dimensions

MY80-SC-28

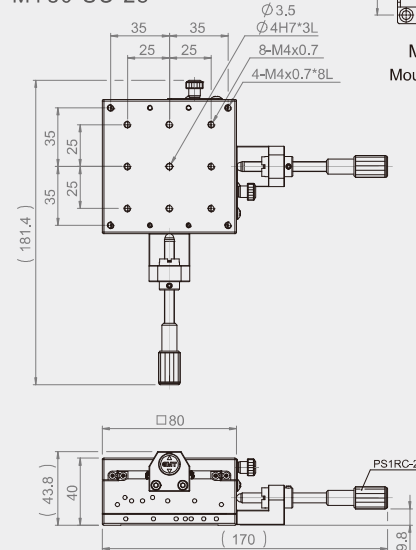

MY80-SS-28

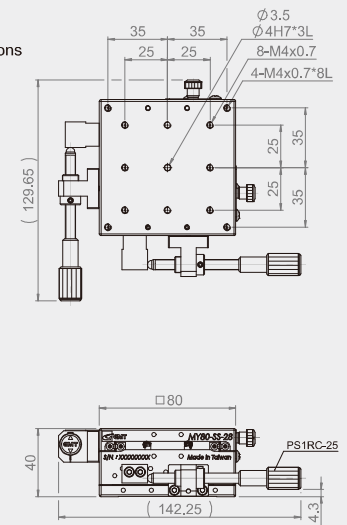

MX100-SC-28



MX100-SS-28



MY100-SC-28



MY100-SS-28

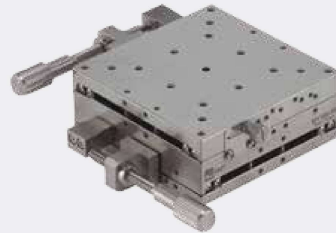

Specification

Unit : mm

Model No.	Table Size	Axis	Feed Position	Travel Stroke	Movement Per Knob Rotation (mm)	Straightness Accuracy (μm)	Allowable Loading (kgf)	Weight (kg)	Material	Surface Finish
MX100-SC-28	100*100	X-axis	Central	±12.5	0.5	3	35	1.33	SUS 440C	Electroless nickel plating
MX100-SS-28			Side							
MY100-SC-28		XY-axis	Central				33.6			
MY100-SS-28			Side							

MX100-SC-28

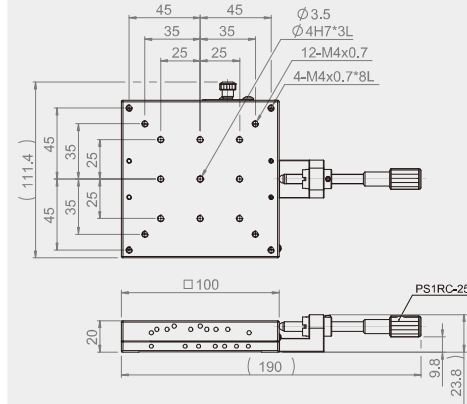

MX100-SS-28

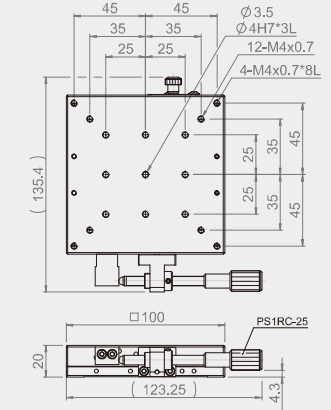

MY100-SC-28

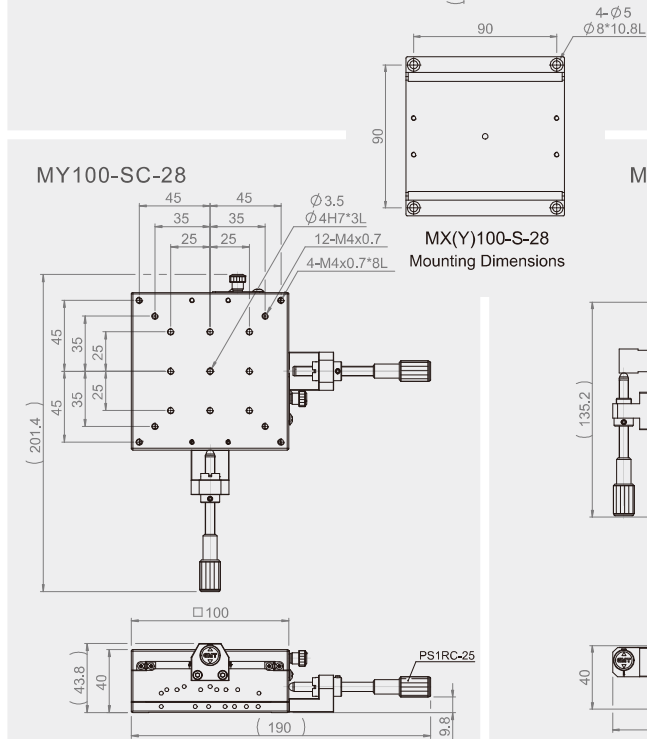

MY100-SS-28

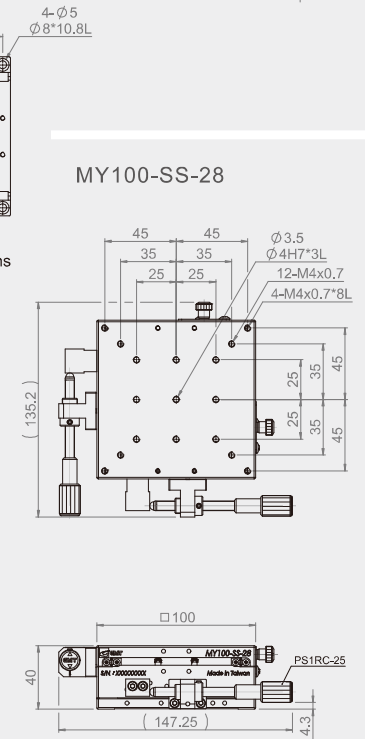

MX(Y)100-S-28 Mounting Dimensions

MX60L-SS-28



Specification

Unit : mm

Model No.	Table Size	Axis	Feed Position	Travel Stroke	Micrometer Minimum Reading (μm)	Straightness Accuracy (μm)	Allowable Loading (kgf)	Weight (kg)	Material	Surface Finish
MX60L-SS-28	60*120	X-axis	Side	±12.5	10	3	16	0.76	SUS440C	Electroless nickel plating

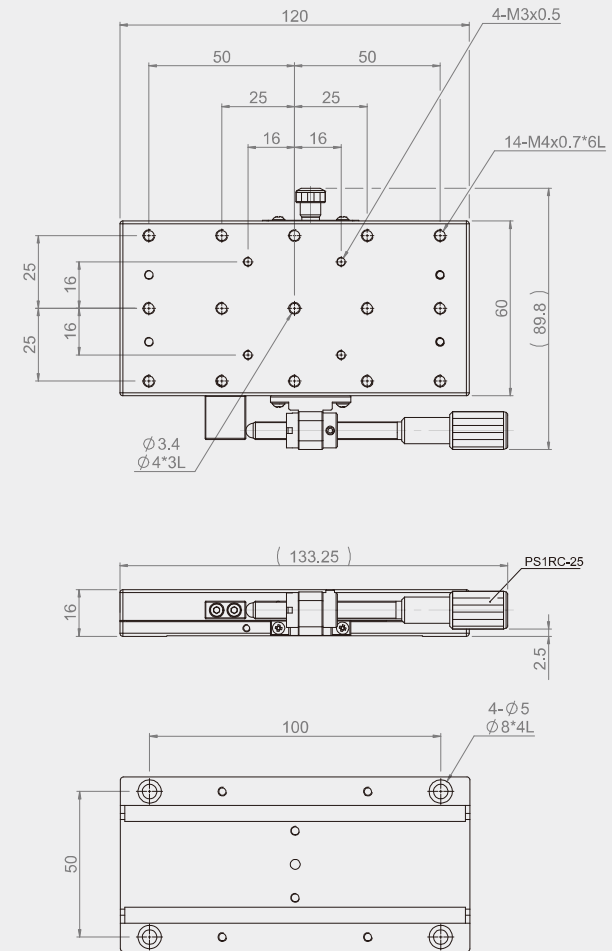

MNG1E-20CL



MNG1E-25CL



MNG1E-40CL



MNG1E-60CL



Specification

Unit : mm

Model No.	Table Size	Axis	Travel Stroke	Minimum Reading (mm)	Allowable Loading (kgf)	Weight (kg)	Material	Surface Finish
MNG1E-20CL	20*20	X-axis	±5	0.5	0.2	0.038	Aluminum alloy	Black anodized
MNG1E-25CL	25*25					0.055		
MNG1E-40CL	40*40					0.104		
MNG1E-60CL	60*60					0.193		

★ A full rotation of the feeding screw knob equals a 0.5mm stroke.

MNG1E-20CL

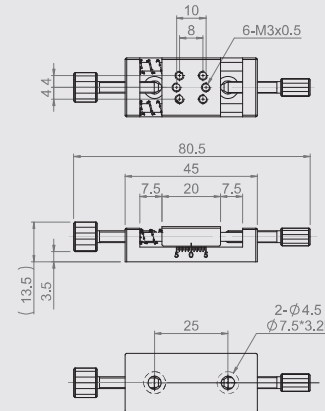

MNG1E-25CL

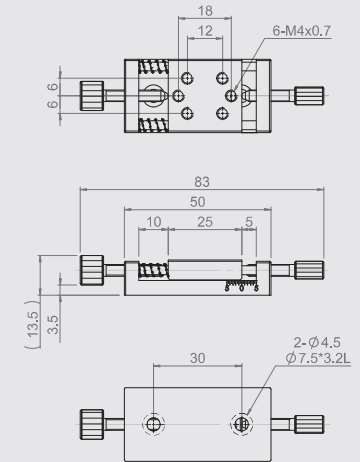

MNG1E-40CL

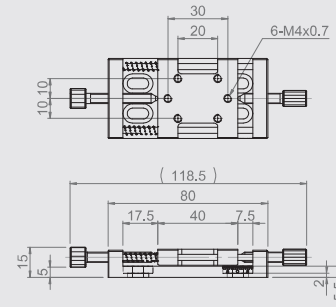

MNG1E-60CL

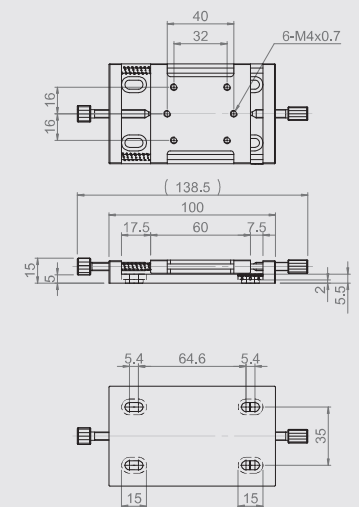

MNG2E-20CL



MNG2E-25CL

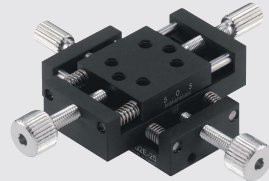

MNG2E-40CL



MNG2E-60CL

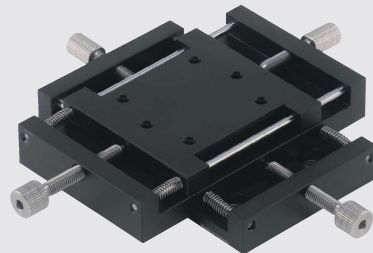

Specification

Unit : mm

Model No.	Table Size	Axis	Travel Stroke	Minimum Reading (mm)	Allowable Loading (kgf)	Weight (kg)	Material	Surface Finish
MNG2E-20CL	20*20	XY-axis	±5	0.5	1	0.038	Aluminum alloy	Black anodized
MNG2E-25CL	25*25					0.055		
MNG2E-40CL	40*40		±7.5		1.5	0.202		
MNG2E-60CL	60*60					0.358		

★ A full rotation of the feeding screw knob equals a 0.7mm stroke.

MNG2E-20CL

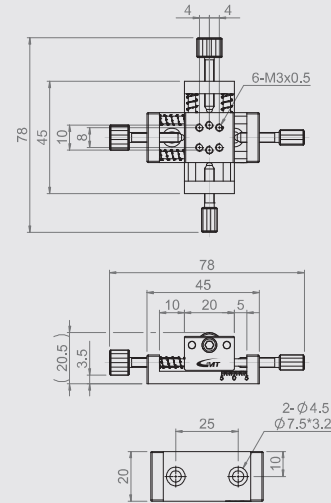

MNG2E-25CL

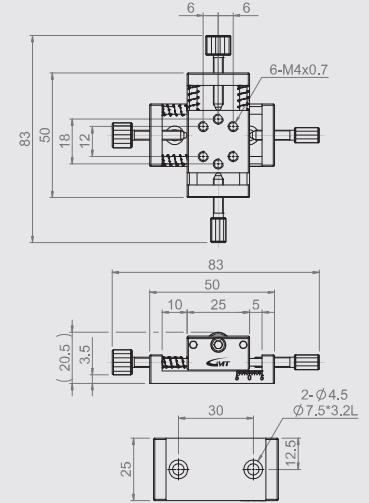

MNG2E-40CL

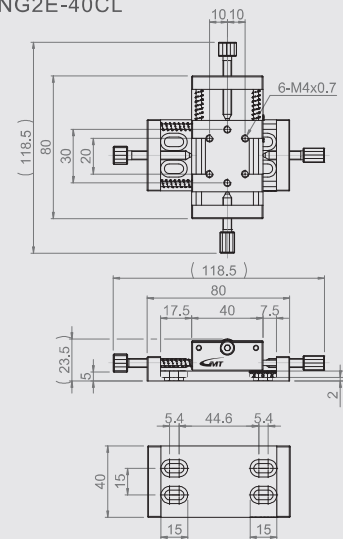

MNG2E-60CL

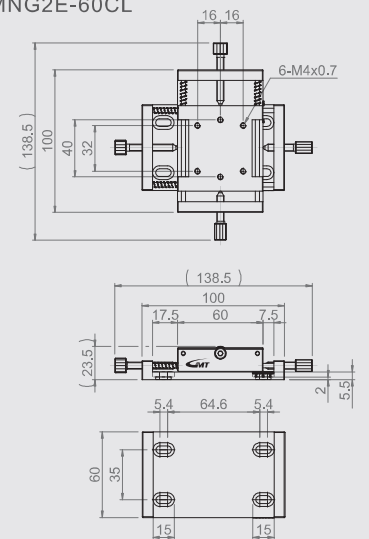

MNE1E-20



MNE1E-25



MNE1E-40



MNE1E-60

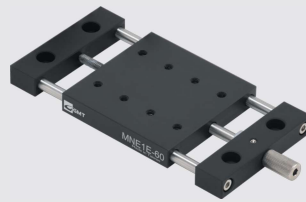

Specification

Unit : mm

Model No.	Table Size	Axis	Travel Stroke	Movement Per Knob Rotation (mm)	Allowable Loading (kgf)	Weight (kg)	Material	Surface Finish	
MNE1E-20	20*20	X-axis	±7	0.7	2	0.039	Aluminum alloy	Black anodized	
MNE1E-25	25*25					0.049			
MNE1E-40	40*40				±9	4			0.104
MNE1E-60	60*60				±13				0.176

MNE1E-20

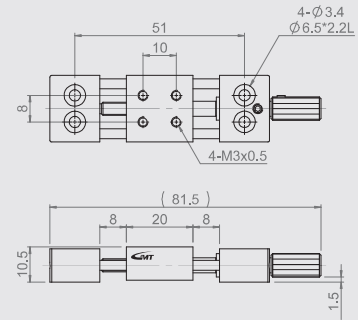

MNE1E-25

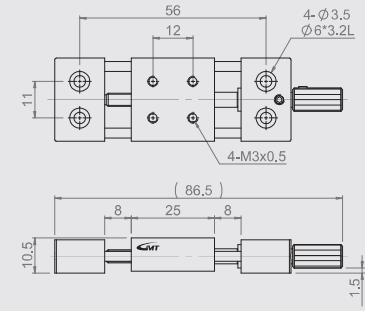

MNE1E-40

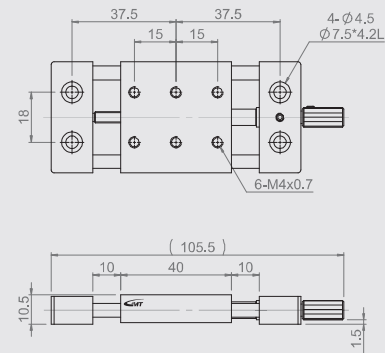

MNE1E-60

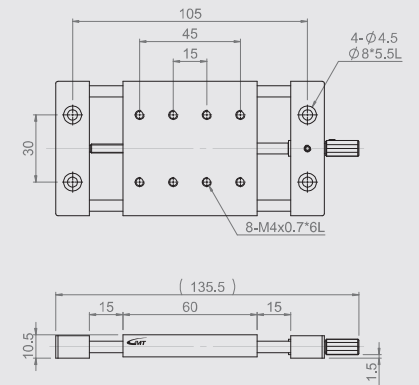

MNE2E-20



MNE2E-25



MNE2E-40



MNE2E-60



Specification

Unit : mm

Model No.	Table Size	Axis	Travel Stroke	Movement Per Knob Rotation (mm)	Allowable Loading (kgf)	Weight (kg)	Material	Surface Finish
MNE2E-20	20*20	XY-axis	±7	0.7	1.9	0.1	Aluminum alloy	Black anodized
MNE2E-25	25*25					0.13		
MNE2E-40	40*40					0.27		
MNE2E-60	60*60					0.48		

MNE2E-20

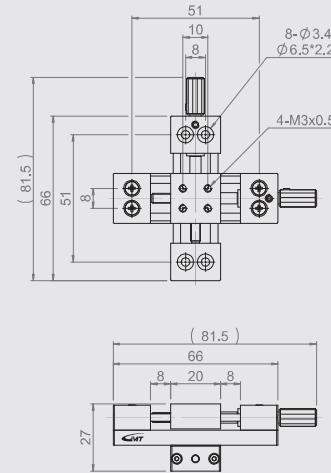

MNE2E-25

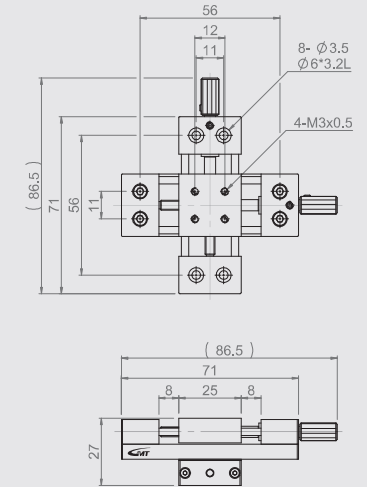

MNE2E-40

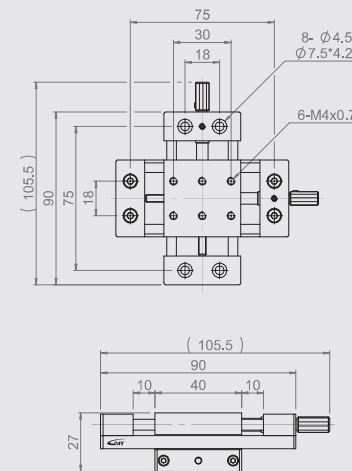

MNE2E-60

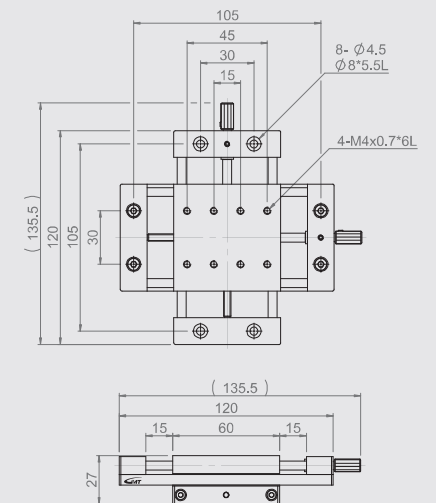

Threaded Type

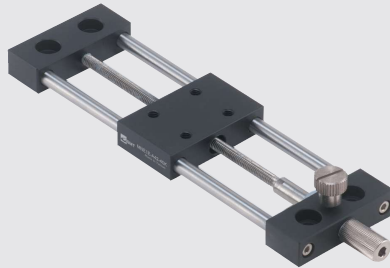

Set Screw Type



Unit : mm

Specification				Part Name	Body	Lead Axle	Knob	Feeding Screw				
Model No.				Material	A6063	SUS 304	SUS 303	SUS 304				
Model No.	Thickness (T)	Table Size Code (E1*E2)	Z (Stroke Options)	Allowable Loading (kgf)	C	Position Fixing Type						
MNE1E	A(10)	44 (40*40)	10, 25, 40, 60	(Z=10, 25) 4	15 mm	S (Set screw) K (Threaded)						
		42 (40*25)		(Z=40, 60) 3.5								
		66 (60*60)	15, 30, 50, 70	(Z=15, 30) 4					S (Set screw) K (Threaded)			
		64 (60*40)		(Z=50, 70) 3.5								
	B(20)	44 (40*40)	10, 25, 40, 60	(Z=10, 25) 8		25 mm	S (Set screw) K (Threaded)					
		42 (40*25)		(Z=40, 60) 7								
		66 (60*60)	15, 30, 50, 70	(Z=15, 30) 8						S (Set screw) K (Threaded)		
		64 (60*40)		(Z=50, 70) 7								

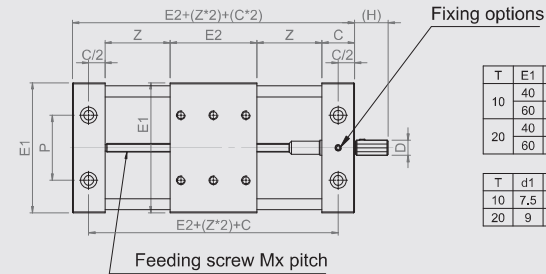

T	E1	P
10	40	18
10	60	30
20	40	14
20	60	30

T	d1	h1	d2
10	7.5	4.2	4.5
20	9	5.2	5.5

T	C	D	(H)	MxPitch	M1
10	15	7	16	M4xP0.7	3
20	25	10	30	M6xP1.0	4

4-Drill d2+C bore d1xh1

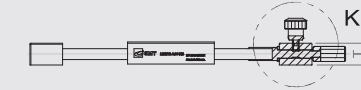
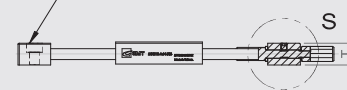

■ Mounting Type

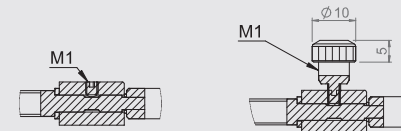

S(Standard set screw)

K(Threaded)

■ Upper Mounting Hole Positions

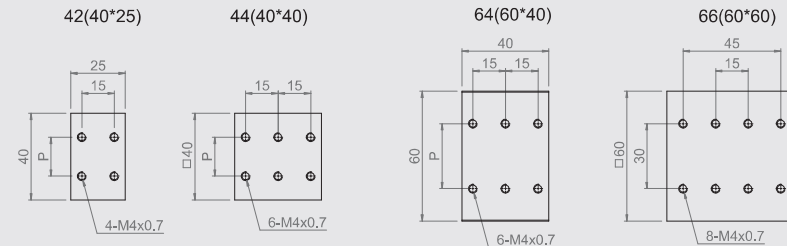

MN1A-12



MN2A-12



Specification

Unit : mm

Model No.	Table Size	Axis	Travel Stroke	Minimum Reading	Straightness Accuracy (μm)	Allowable Loading (kgf)	Weight (kg)	Material	Surface Finish
MN1A-12	12*13	X-axis	±1.7	No scale	50	0.5	0.005	Aluminum alloy	Black anodized
MN1A-15	15*17		±5			1	0.02		
MN2A-12	12*13	XY-axis	±1.7			0.5	0.01		
MN2A-15	15*17		±5			1	0.04		

MN1A-12

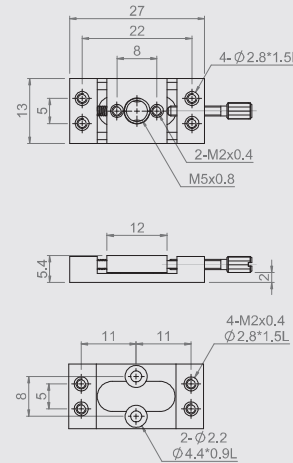

MN1A-15

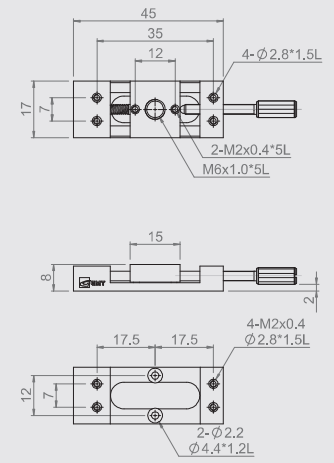

MN2A-12

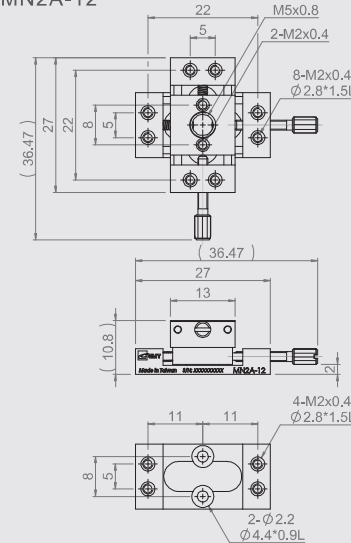

MN2A-15

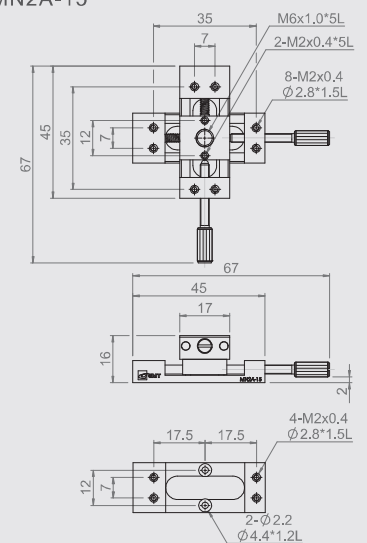

MZA-60



MZA-25

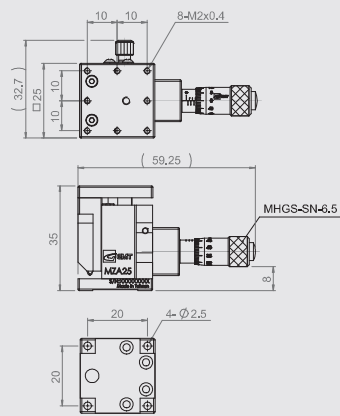

MZA-40

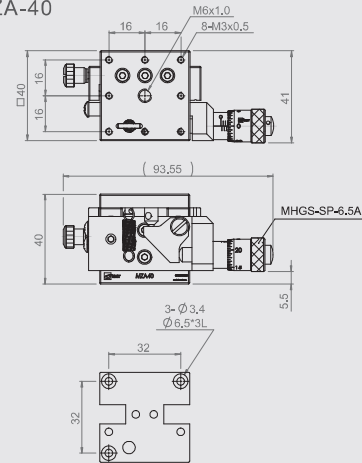

Specification

Unit : mm

Model No.	Table Size	Travel Stroke	Micrometer Minimum Reading (μm)	Parallelism (μm)	Straightness Accuracy (μm)	Allowable Loading (kgf)	Weight (kg)	Material	Surface Finish
MZA-25	25*25	± 2.0	10	100	3	1	0.06	Aluminum alloy	Black anodized
MZA-40	40*40	± 3.0				1	0.2		
MZA-40H	40*40	± 3.0				2	0.2		
MZA-60L	60*60	± 3.0				2	0.3		
MZA-60	60*60	± 5.0				4	0.6		
MZA-80	80*80					3	1.0		

MZA-40H

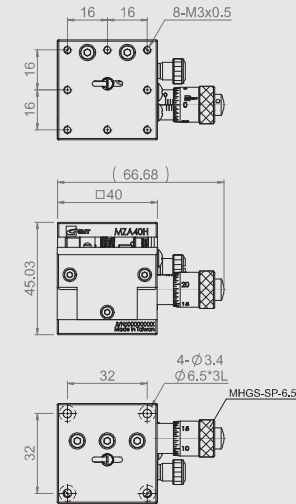

MZA-60L

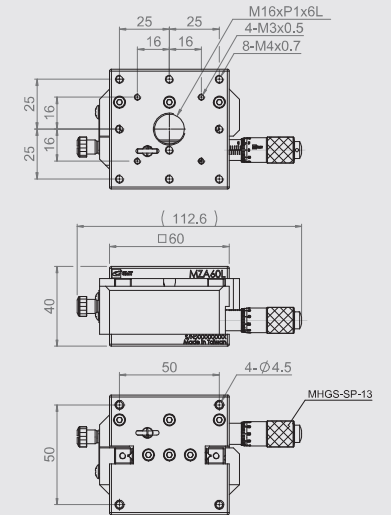

MZA-60

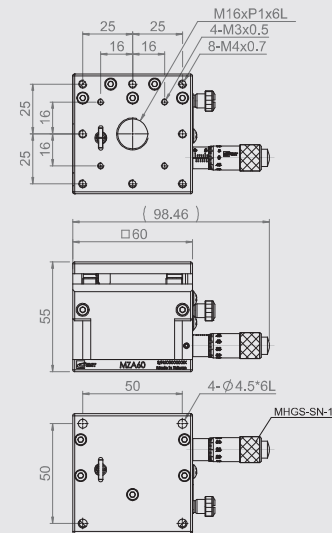

MZA-80

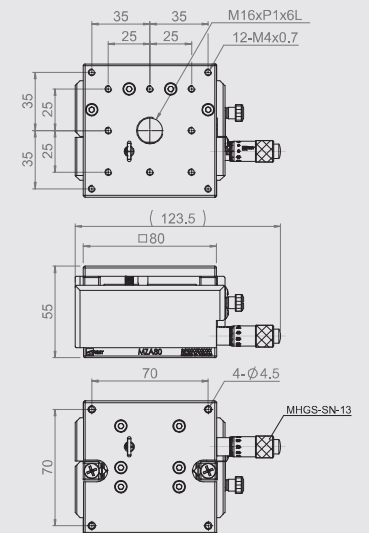

MZA1-5060

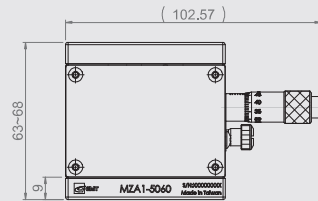
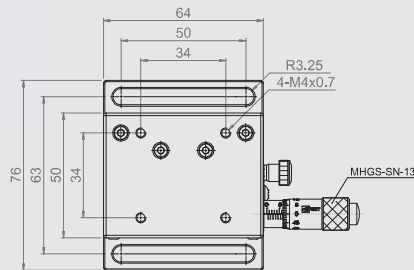

Specification

Unit : mm

Model No.	Table Size	Travel Stroke	Micrometer Minimum Reading (μm)	Horizontal Deviation of Elevation (mm)	Allowable Loading (kgf)	Weight (kg)	Material	Surface Finish
MZA1-5060	50*64	5	10	0.03	7	0.62	Aluminum alloy	Black anodized
MZA2-5060					8	0.63		
MZA3-5060					10	0.72		

MZA2-5060

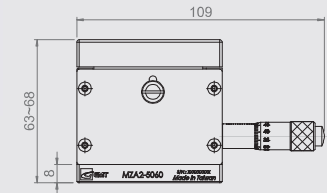
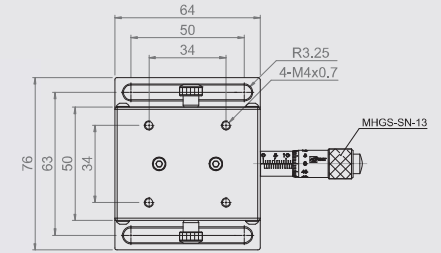

MZA3-5060

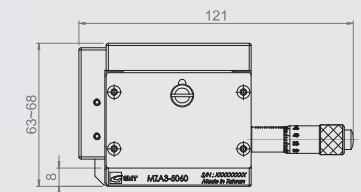
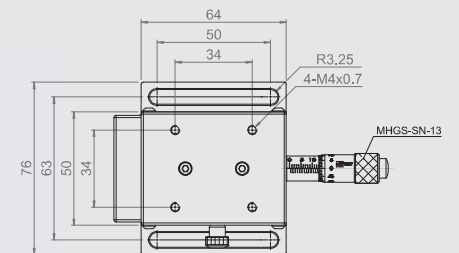

MZF-80



MZF-120

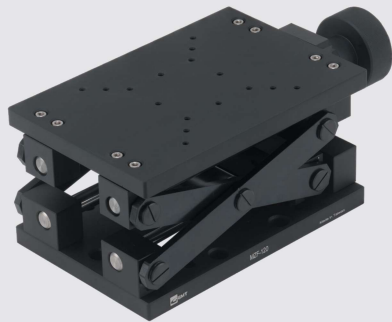

Specification

Unit : mm

Model No.	Table Size	Travel Stroke	Movement Per Knob Rotation	Parallelism (μm)	Allowable Loading (kgf)	Weight (kg)	Material	Surface Finish
MZF-80	80*120	40	2	200	7	1.25	Aluminum alloy	Black anodized
MZF-120	120*180	70	3		10	3.5		

MZF-80

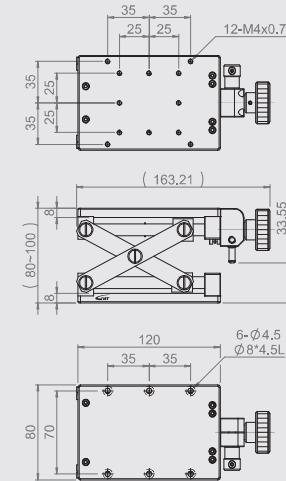

MZF-120

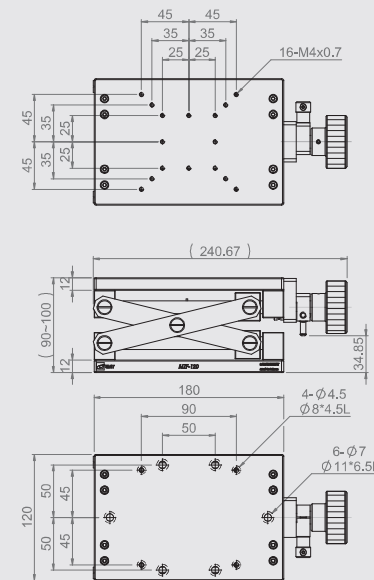

MR38-AR



MR60-AR



Specification

Unit : mm

Model No.	Table Size	Travel Stroke	Rotation Accuracy	Micrometer Minimum Reading	Offset (Eccentric)	Allowable Loading (kgf)	Weight (kg)	Material	Surface Finish
MR38-AR	Ø 38	Cursory 360° Fine ± 5°	0.2°	≒ 1'26"/ Vernier	0.05	1	0.09	Aluminum alloy	Black anodized
MR60-AR	Ø 60			≒ 55"/ Vernier		3	0.28		
MR85-AR	Ø 85	0.1°	≒ 43"/ Vernier	4	0.48				
MR110-AR	Ø 110		≒ 34"/ Vernier	5	0.75				

★ MR series have been integrated with the brass rotation interface.

MR38-AR

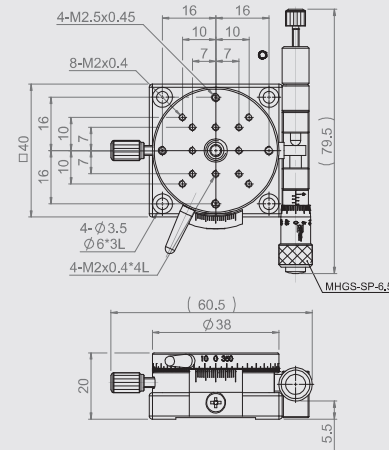

MR60-AR

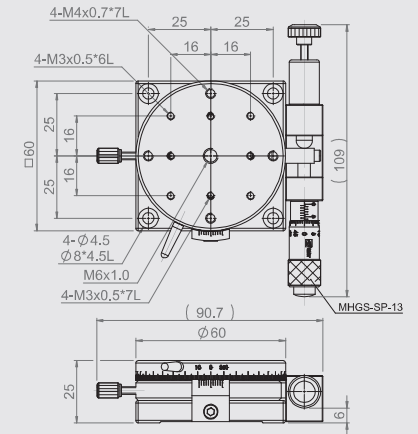

MR85-AR

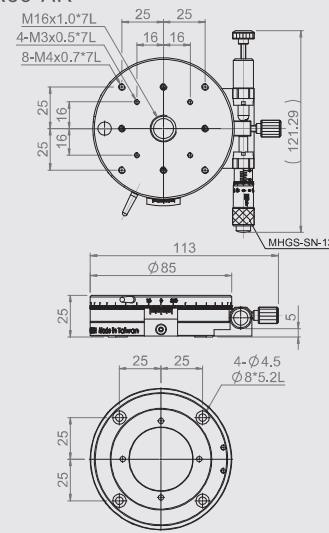

MR110-AR

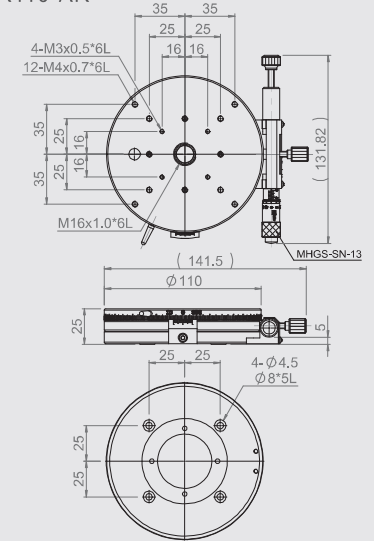

MR50-AR-48

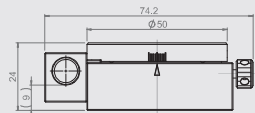
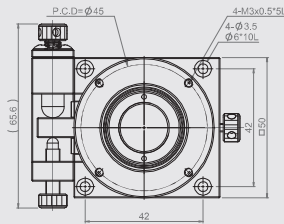
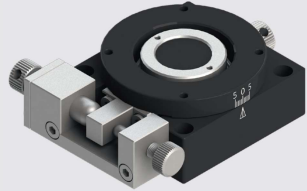

MR85-S

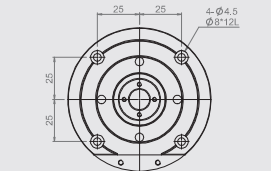
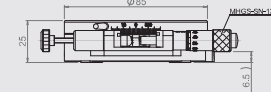
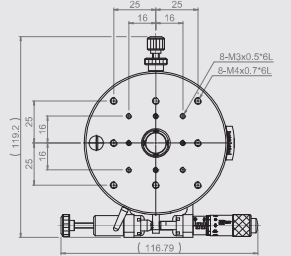

- ★ Combinable with MC1B (P.149) · MC2B (P.150) · MC4B (P.151) · MC1C (P.152)
- ★ MRE-60AL requires ASAP 60' (page 233)

MRE40-A

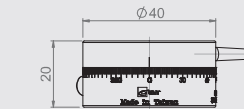
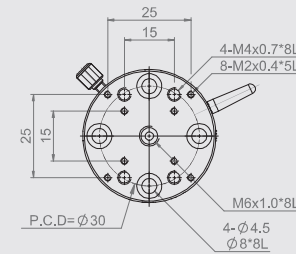

MRE60-A

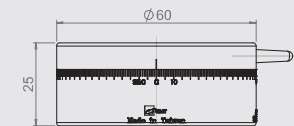
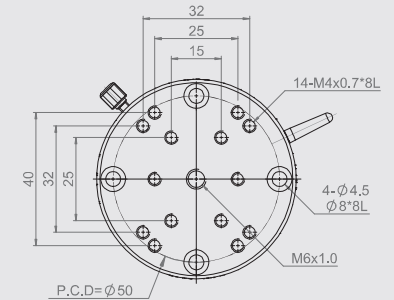

Specification

Unit : mm

Model No.	Table Size	Axis	Travel Stroke	Micrometer Minimum Reading	Offset (Eccentric)	Allowable Loading (kgf)	Weight (kg)	Material	Surface Finish
MR50-AR-48	φ 50	Θ-axis	±5.5"	0.1"	0.05	1.8	0.26	Aluminum alloy	Black anodized
MR85-S	φ 85		360° Cursory ±5.5'(Fine)			6	1	Stainless steel	

Specification

Unit : mm

Model No.	Table Size	Travel Stroke	Micrometer Minimum Reading	Offset (Eccentric)	Allowable Loading (kgf)	Weight (kg)	Material	Surface Finish
MRE40-A	φ 40	Cursory 360°	2°	0.05	5	0.14	Aluminum alloy	Black anodized
MRE60-A	φ 60		1°		7	0.2		

MRE85-A



MRE110-A



MRE85-A

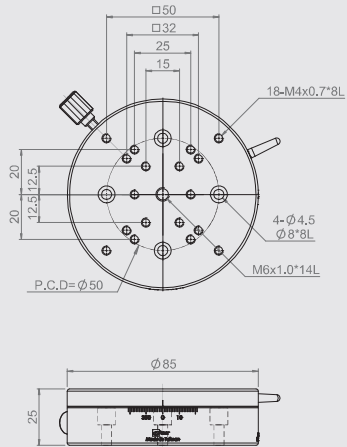

MRE110-A

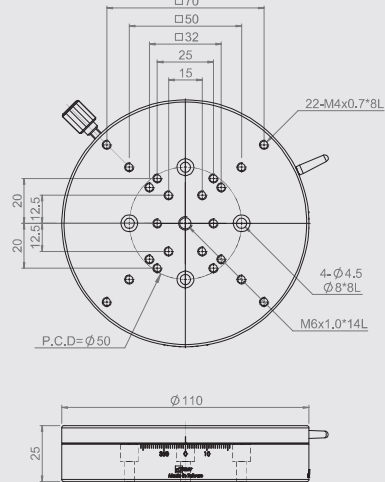

Specification

Unit : mm

Model No.	Table Size	Travel Stroke	Micrometer Minimum Reading	Offset (Eccentric)	Allowable Loading (kgf)	Weight (kg)	Material	Surface Finish
MRE85-A	Ø 85	Cursory 360°	1*	0.05	8	0.4	Aluminum alloy	Black anodized
MRE110-A	Ø 110				9	0.66		

MMT-38

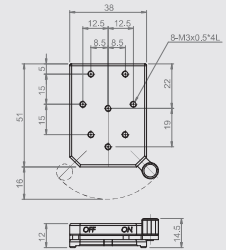
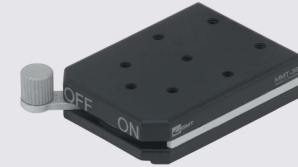

MMT-52

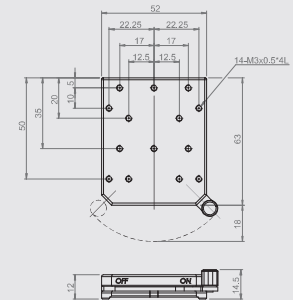

MMT-66

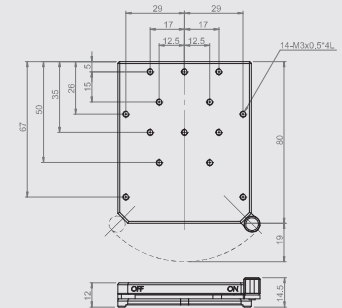
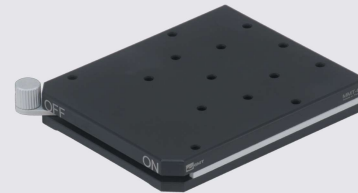

Specification

Unit : mm

Model No.	Table Size	Magnetic (kgf)	Parallelism	Weight (kg)	Material	Surface Finish
MMT-38	12*38*51	1.0	0.015	0.3	Carbon steel	Black Zinc plated
MMT-52	12*52*63	3.3	0.02	0.6		
MMT-66	12*66*80	3.8	0.02	1.2		

★ Customized mounting holes are available in case the holes do not match.

MMS-45



MMS-65

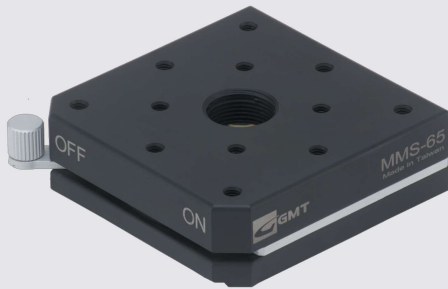

Specification

Unit : mm

Model No.	Table Size	Magnetic Force (kgf)	Parallelism	Weight (kg)	Material	Surface Finish
MMS-45	20*45*45	17.0	0.015	0.3	Carbon steel	Black zinc plated
MMS-65	20*65*65	20.0	0.02	0.6		
MMS-90	20*90*90	25.0	0.02	1.2		
MMS-125	20*125*125	70.0	0.02	2.8		

MMS-45

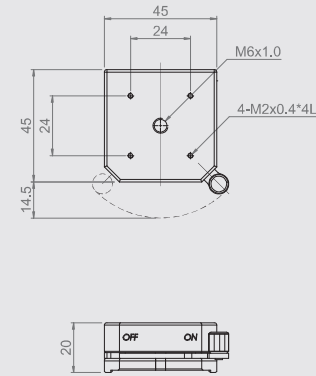

MMS-65

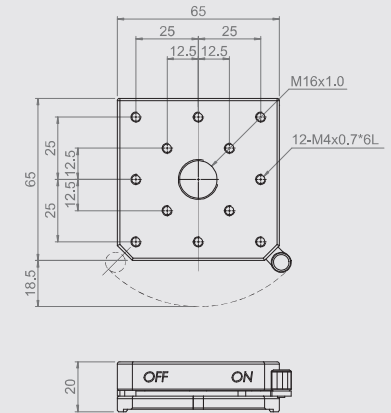

MMS-90

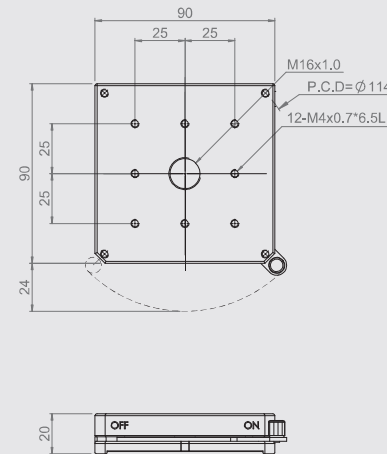

MMS-125

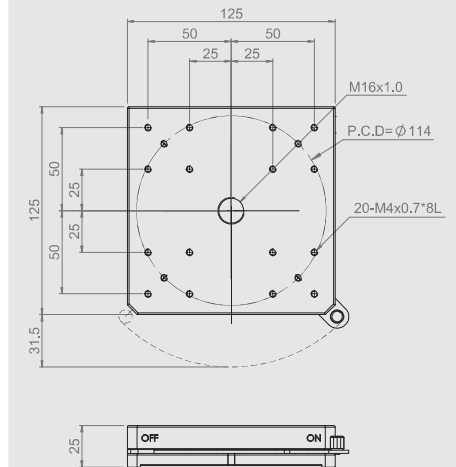

MTB-80



Specification

Unit : mm

Model No.	Table Size	Movement Direction	Transmission	Travel Stroke	Allowable Loading (kgf)	Weight (kg)	Material	Surface Finish
MTB-40	40*40	2 directions	0.54° per manual rotation	±2°	2	0.03	Aluminum alloy	Black anodized
MTB-60	60*60				4	0.15		
MTB-80	80*80				5	0.4		

★ Customized mounting holes are available in case the holes do not match.

MTB-40

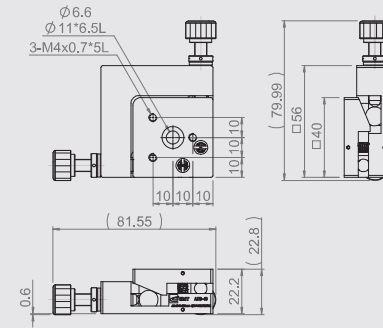

MTB-60

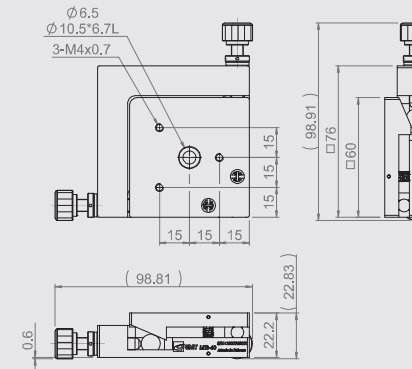

MTB-80

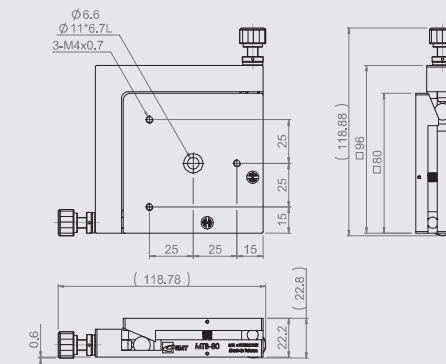

MTS-30



MTS-60



MTS-90

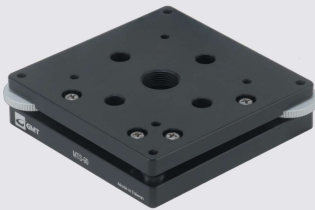

MTS-125

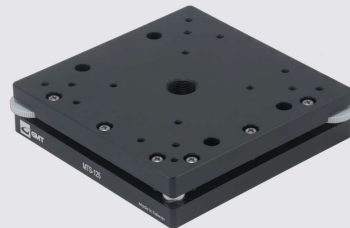

Specification

Unit : mm

Model No.	Table Size	Travel Direction	Transmission	Travel Stroke	Allowable Loading (kgf)	Weight (kg)	Material	Surface Finish
MTS-30	30*30	2 directions	1° 25' per manual rotation 0° 40' per manual rotation 0° 24' per manual rotation 0° 15' per manual rotation	±2°	2	0.03	Aluminum alloy	Black anodized
MTS-60	60*60				4	0.15		
MTS-90	90*90				5	0.4		
MTS-125	125*125				5	1.0		

MTS-30

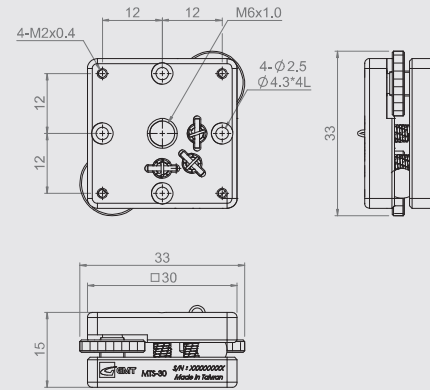

MTS-60

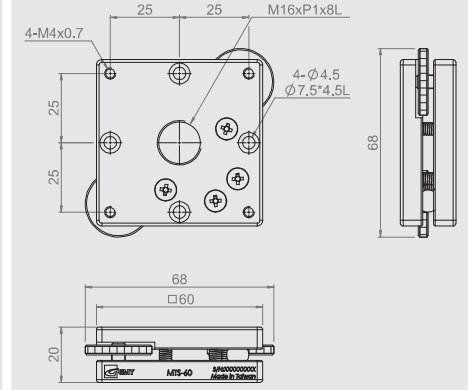

MTS-90

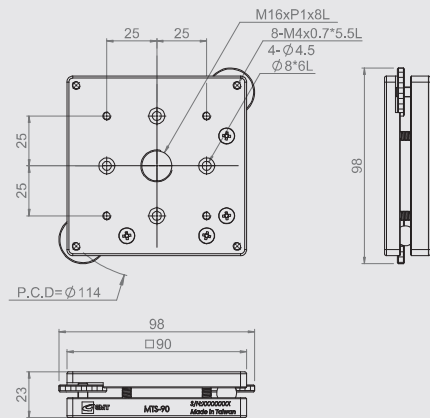

MTS-125

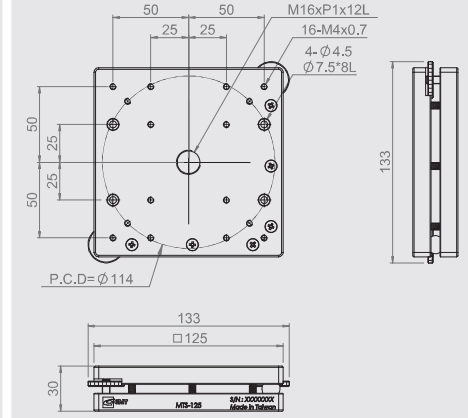

ASAP-40

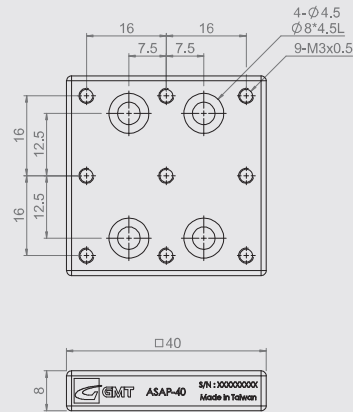

ASAP-60

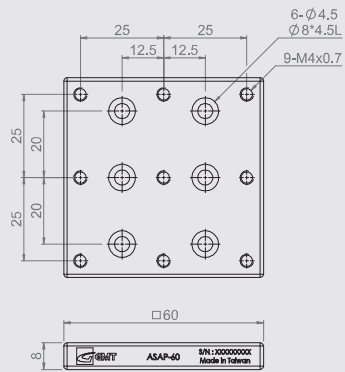

ASAP-80

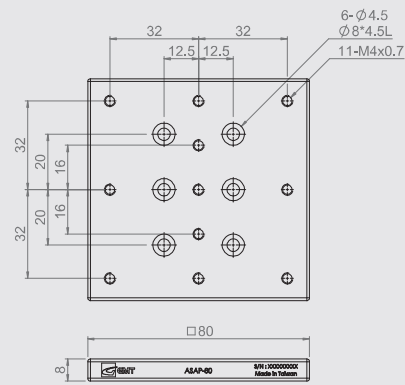

Specification

Unit : mm

Model No.	Table Size	Material	Surface Finish	Suitable for The Following Gmt Stage Models
ASAP-40	40*40	Aluminum alloy	Black anodized	MC1B-40, MC2B-40, MC4B-40
ASAP-60	60*60			MC1B-60, MC1B-90, MC1B-140
ASAP-80	80*80			MC2B-60, MC2B-90, MC4B-60, MC4B-90

AIB-□-120-120

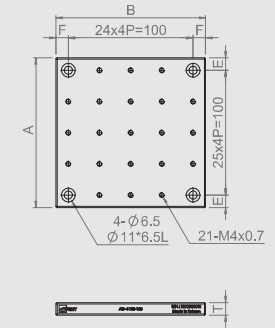
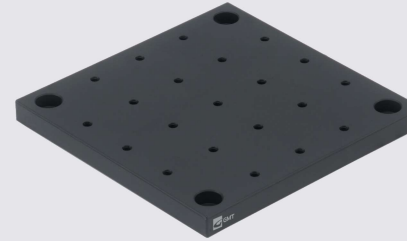

EAIB-□-120-200

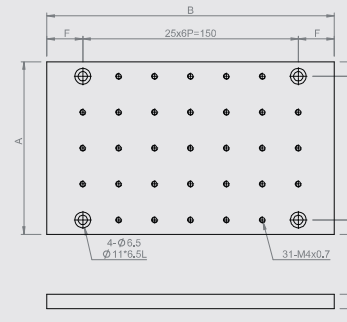

EAIB-□-120-300

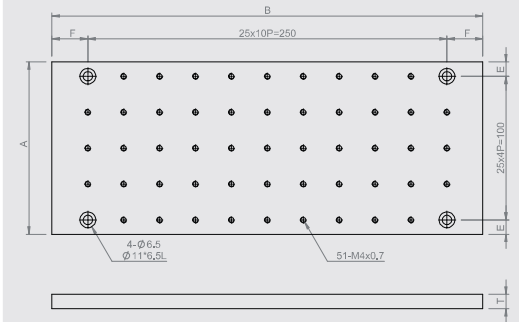

Specification

Unit : mm

Model No.		A	B	Numbers of Hole	T	E	F	Material	Surface Finish
M4	M6	120	120	21	10	10	10	Aluminum alloy	Black anodized
AIB-4-120-120	AIB-6-120-120		200	31					
EAIB-4-120-200	EAIB-6-120-200		300	51					
AIB-4-150-150	AIB-6-150-150	150	150	21	10	25	25	Aluminum alloy	Black anodized
EAIB-4-150-200	EAIB-6-150-200		200	31					
EAIB-4-150-300	EAIB-6-150-300		300	51					
AIB-4-200-200	AIB-6-200-200	200	200	45	10	25	25	Aluminum alloy	Black anodized
EAIB-4-200-300	EAIB-6-200-300		300	73					
EAIB-4-300-600	EAIB-6-300-600		600	272					
EAIB-4-450-600	EAIB-6-450-600	450	600	410					

★ 4 * M6 mounting holes have been initially set on the 100 mm area in the middle of the plate.

★ Suitable for the precision stages, or can be mounted on the anti-vibration platform.

M C 2 A - 60

Transmission	Guide Device	Axis	Feeding Specification	Stage Dimension
M : Manual	C : Dovetail type	1 : X-axis	A : Feeding screw	Selectable from catalogue
	T: Tilt type	2 : XY-axis	B : Rack and pinion	
	M : Magnetic type	3 : Z-axis	C : Rack and pinion with long stroke	
	Z : Horizontal Z axis	4 : X-axis+L bracket	D : Rack and pinion in simple design	
	N : Double bars with single spring	5 : XZ-axis	E : Feeding screw (Hex. Wrench type)	
	NG : Double bars with double springs	6 : XYZ-axis	F : Standard micrometer	
	NE : Double bars	7 : XX-axis	G : Feeding screw (Knob with scale)	

M C S - 44 W L

Transmission	Guide Device	Axis	Dimension	Knob Type	Stroke Direction
M : Manual	C : Dovetail type	S : X-axis	Selectable from catalogue	NIL : Single knob	NIL : Z-axis (Up & Down stroke)
		D : XY-axis		W : Double knobs	L : Z-axis (Up stroke)
		V : Z-axis			
		M : XZ-axis			
		T : XY-axis+Z-plate			

MC1A-60



MC1A-25

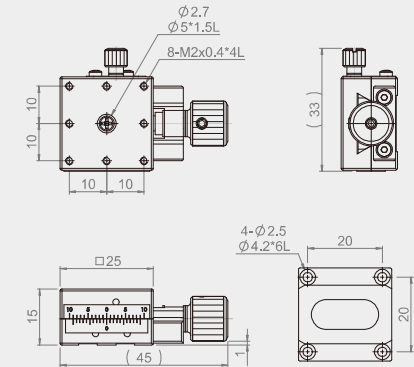

MC1A-40

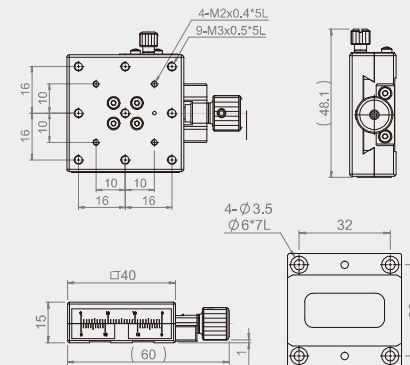

MC1A-60

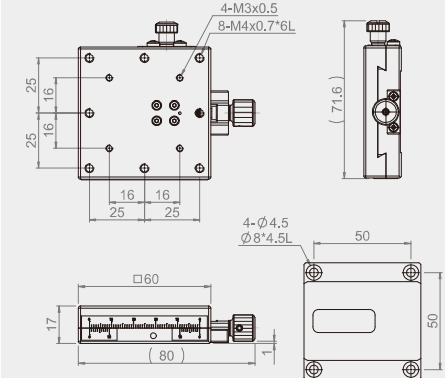

Specification

Unit : mm

Model No.	Table Size	Travel Stroke	Micrometer Minimum Reading	Straightness Accuracy (μm)	Allowable Loading (kgf)	Weight (kg)	Material	Surface Finish
MC1A-25	25*25	±3	0.1 mm / Vernier	30	3	0.07	Stage body : brass alloy feeding screw Knob : aluminum	Black fluororesin finished
MC1A-40	40*40	±7			3	0.19		
MC1A-60	60*60	±9			4	0.47		

★ A full rotation of the feeding screw knob equals a 0.5mm stroke.

MC2A-60



MC2A-25

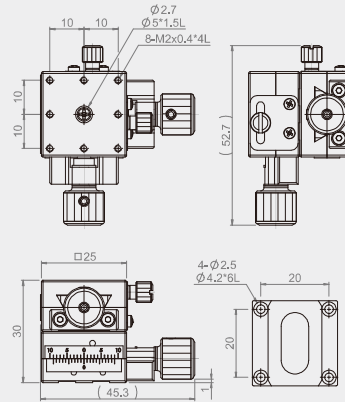

MC2A-40

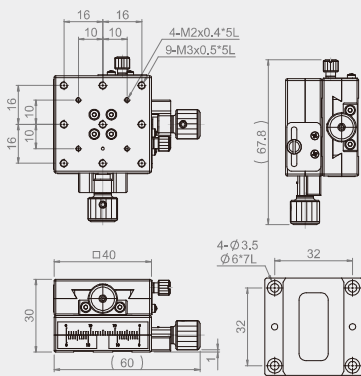

MC2A-60

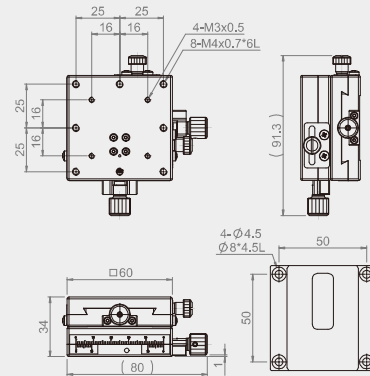

Specification

Unit : mm

Model No.	Table Size	Travel Stroke	Micrometer Minimum Reading	Straightness Accuracy (μm)	Allowable Loading (kgf)	Weight (kg)	Material	Surface Finish
MC2A-25	25*25	±3	0.1 mm / Vernier	30	2.9	0.15	Stage body : brass alloy feeding screw Knob : aluminum	Black fluororesin finished
MC2A-40	40*40	±7			2.8	0.38		
MC2A-60	60*60	±9			3.4	1.2		

★ A full rotation of the feeding screw knob equals a 0.5mm stroke.

MC4A-60



MC4A-25

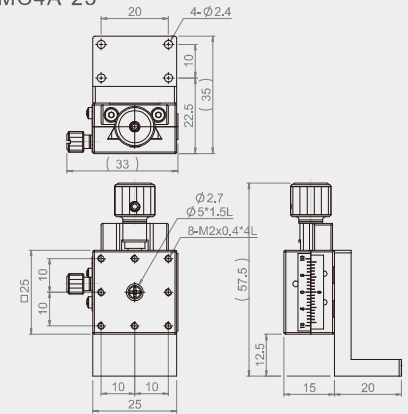

MC4A-40

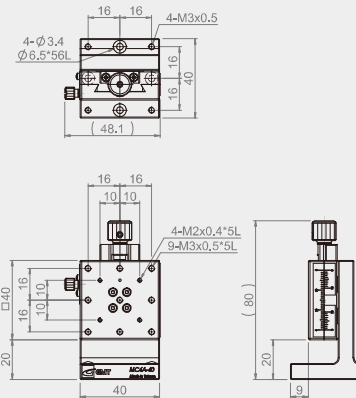

MC4A-60

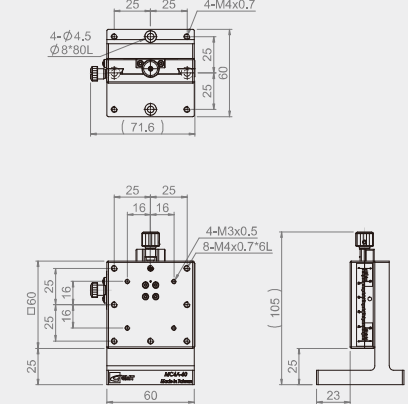

Specification

Unit : mm

Model No.	Table Size	Travel Stroke	Micrometer Minimum Reading	Straightness Accuracy (μm)	Allowable Loading (kgf)	Weight (kg)	Material	Surface Finish
MC4A-25	25*25	±3	0.1 mm / Vernier	30	1	0.09	Stage body : brass alloy feeding screw Knob:aluminum	Black fluororesin finished
MC4A-40	40*40	±7			1	0.26		
MC4A-60	60*60	±9			2	0.75		

★ A full rotation of the feeding screw knob equals a 0.5mm stroke.

MC1A-A40

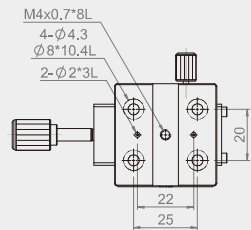
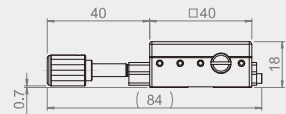
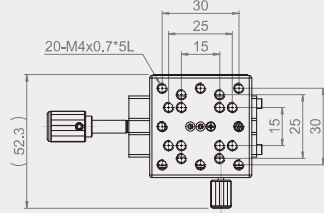
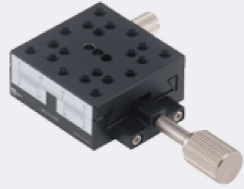

MC1A-A60

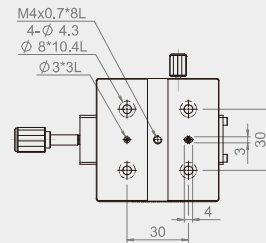
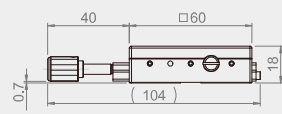
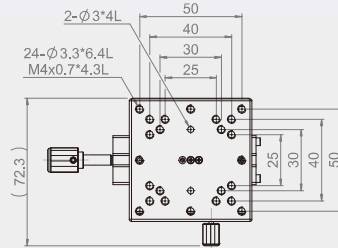

Specification

Unit : mm

Model No.	Table Size	Axis	Feed Position	Travel Stroke	Minimum Reading	Straightness Accuracy (μm)	Allowable Loading (kgf)	Weight (kg)	Material	Surface Finish
MC1A-A40	40*40	X-axis	Central	± 11	0.1mm/ Vernier	30	2	0.10	Aluminum alloy	Black anodized
MC1A-A60	60*60			± 21			3			

MC4A-A60

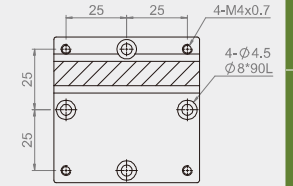
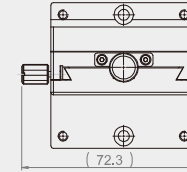

cross section A-A

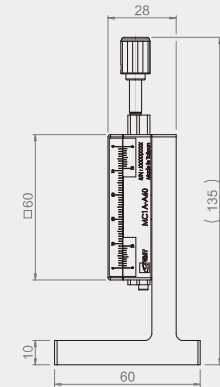
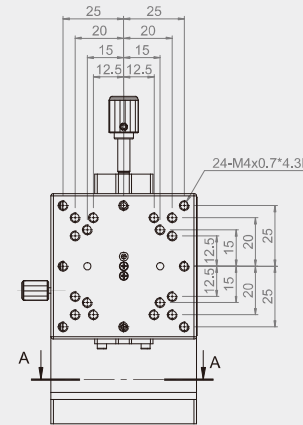

Specification

Unit : mm

Model No.	Table Size	Axis	Feed Position	Travel Stroke	Movement Per Knob Rotation	Minimum Reading	Straightness Accuracy (μm)	Allowable Loading (kgf)	Weight (kg)	Material	Surface Finish
MC4A-A60	60*60	Z-axis	Central	±21	4.2	0.1 mm / Vernier	30	2.1	0.42	Aluminum alloy	Black anodized

MC1A-60CL

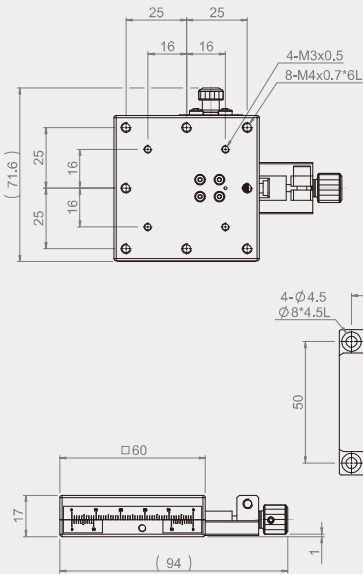
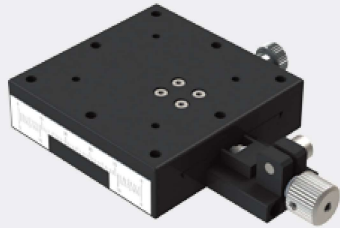

MC2A-60CL

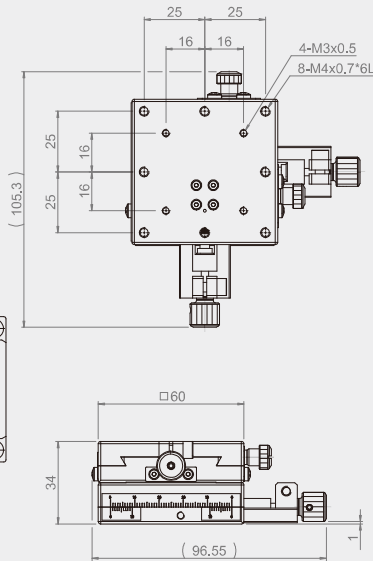
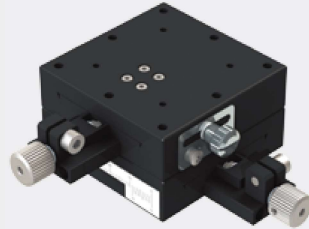

Specification

Unit : mm

Model No.	Table Size	Axis	Feed Position	Travel Stroke	Movement Per Knob Rotation	Minimum Reading	Straightness Accuracy (μm)	Allowable Loading (kgf)	Weight (kg)	Material	Surface Finish
MC1A-60CL	60*60	X-axis	Central	±9	0.5	0.1 mm / Vernier	30	4	0.47	Stage body : brass alloy feeding screw Knob : aluminum	Black fluororesin finished
MC2A-60CL		XY-axis						3.4	0.98		

MC1A-46L



MC1A-46L

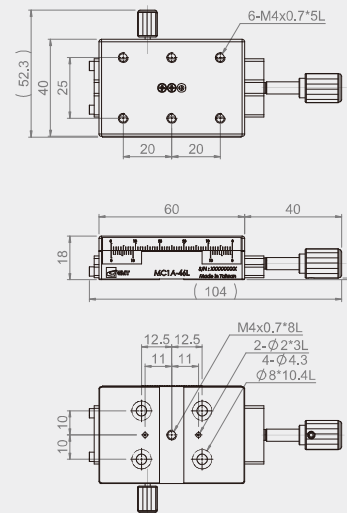

MC1A-49L

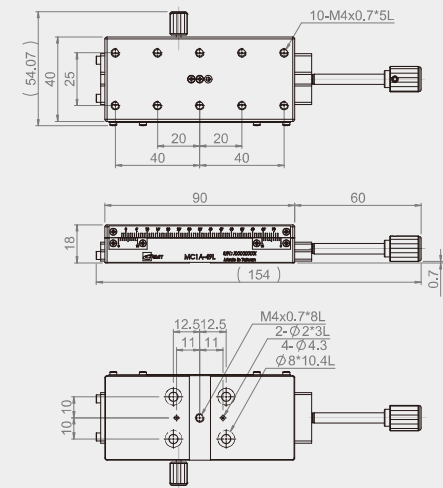

Specification

Unit : mm

Model No.	Table Size	Axis	Feed Position	Travel Stroke	Minimum Reading	Straightness Accuracy (μm)	Allowable Loading (kgf)	Weight (kg)	Material	Surface Finish
MC1A-46L	40*40	X axis	Central	± 21	0.1mm / Vernier	30	3	0.14	Aluminum alloy	Black anodized
MC1A-49L	40*90			± 35			3	0.19		

MC1A-46C

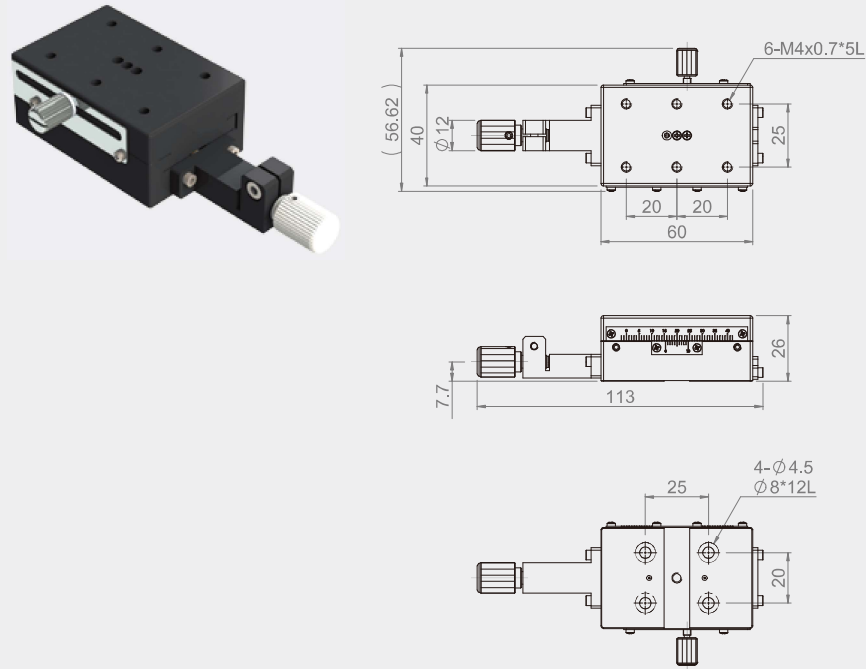

Specification

Unit : mm

Model No.	Table Size	Axis	Feed Position	Travel Stroke	Minimum Reading	Straightness Accuracy (mm)	Dynamic Straightness Accuracy (mm)	Dynamic Parallel (mm)	Horizontal/ Vertical Loading (kgf)	Weight (kg)	Material	Surface Finish
MC1A-46C	40*60	X-axis	Central	±21	0.1 mm / Vernier	0.01	0.03	0.03	4 / 2	0.19	Aluminum alloy	Black anodized

MC1A-46S

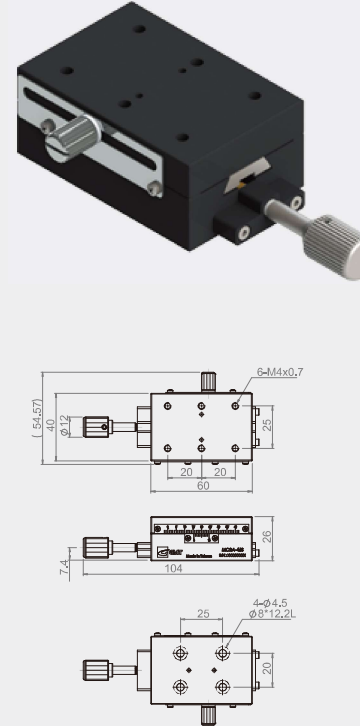

Specification

Unit : mm

Model No.	Table Size	Axis	Feed Position	Travel Stroke	Minimum Reading	Straightness Accuracy (mm)	Dynamic Straightness Accuracy (mm)	Dynamic Parallel (mm)	Horizontal/ Vertical Loading (kgf)	Weight (kg)	Material	Surface Finish
MC1A-46S	40*60	X-axis	Central	±21	0.1 mm / Vernier	0.03	0.03	0.03	4 / 2	0.19	Aluminum alloy	Black anodized
MC1A-49S	40*90			±35						0.29		

MC2A-46S

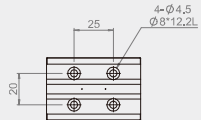
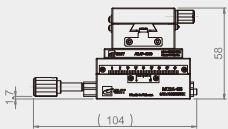
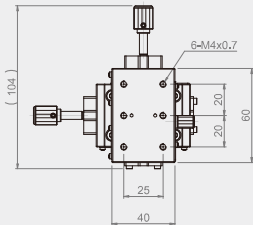
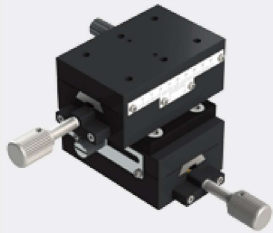

MC2A-49S

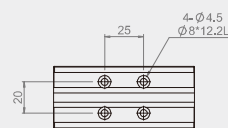
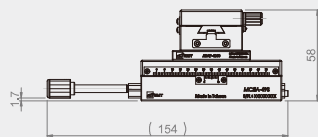
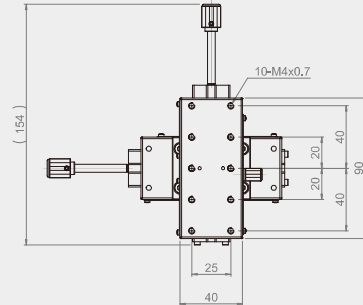

Specification

Unit : mm

Model No.	Table Size	Axis	Feed Position	Travel Stroke	Movement Per Knob Rotation	Minimum Reading	Straightness Accuracy (µm)	Allowable Loading (kgf)	Weight (kg)	Material	Surface Finish
MC2A-46S	40*60	XY-axis	Central	±21	4.2	0.1 mm / Vernier	30	3.8	0.43	Aluminum alloy	Black anodized
MC2A-49S	40*90			±35				3.72	0.62		

MC4A-49S

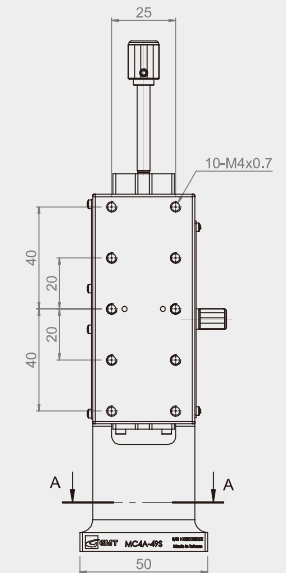
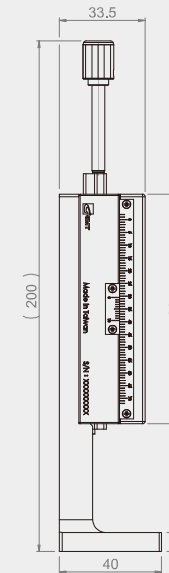
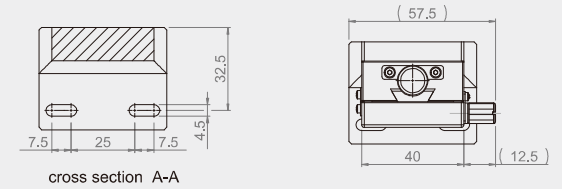

Specification

Unit : mm

Model No.	Table Size	Axis	Feed Position	Travel Stroke	Movement Per Knob Rotation	Minimum Reading	Straightness Accuracy	Allowable Loading (kgf)	Weight (kg)	Material	Surface Finish
MC4A-49S	40*90	Z-axis	Central	±35	4.2	0.1 mm / Vernier	30 µm	2	0.46	Aluminum alloy	Black anodized

MC1A-425

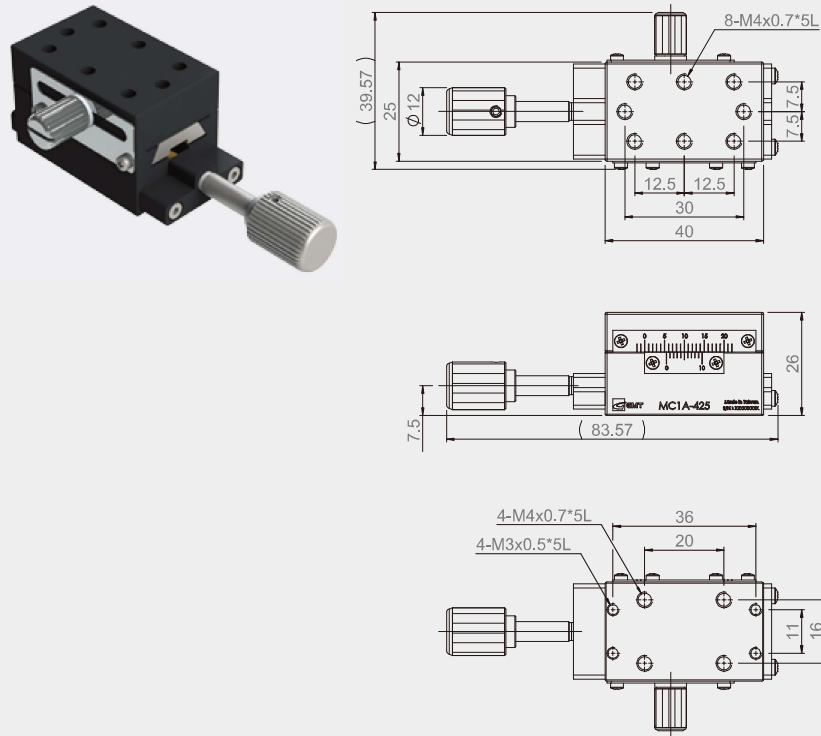

Specification

Unit : mm

Model No.	Table Size	Axis	Feed Position	Travel Stroke	Minimum Reading	Straightness Accuracy (mm)	Dynamic Straightness Accuracy (mm)	Dynamic Parallel (mm)	Horizontal/ Vertical Loading (kgf)	Weight (kg)	Material	Surface Finish
MC1A-425	25*40	X-axis	Central	±12	0.1 mm / Vernier	0.01	0.02	0.03	3 / 1.5	0.09	Aluminum alloy	Black anodized

MC1AL-40

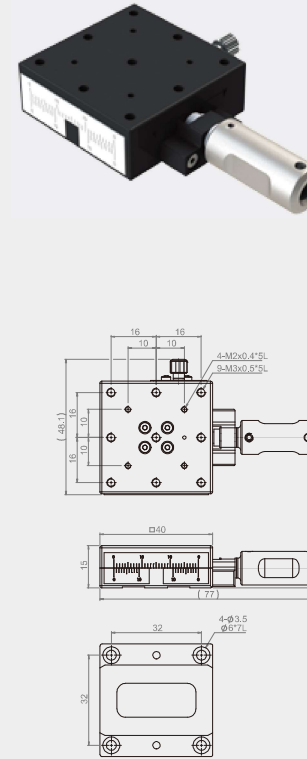

MC4AL-40

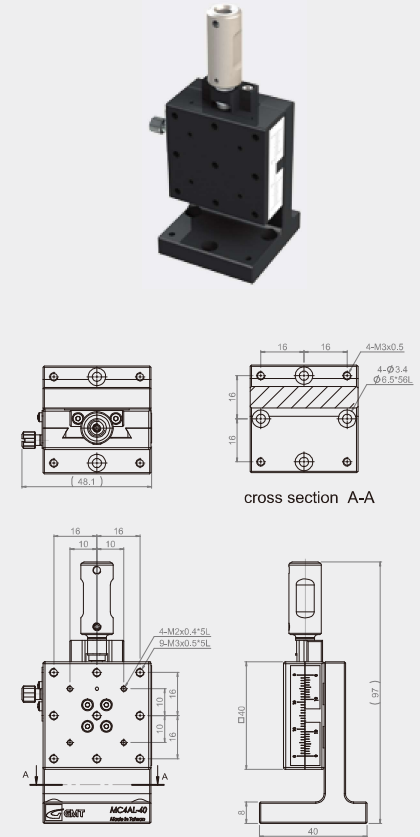

Specification

Unit : mm

Model No.	Table Size	Axis	Feed Position	Travel Stroke	Movement Per Knob Rotation	Minimum Reading	Straightness Accuracy (μm)	Allowable Loading (kgf)	Weight (kg)	Material	Surface Finish
MC1AL-40	40*40	X-axis	Central	±7	0.5	0.1 mm / Vernier	30	3	0.2	Stage body : brass Alloy feeding screw Knob : aluminum	Black fluororesin finished
MC4AL-40		Z-axis						2.1	0.28		

MC1A-48KM



MC1A-48KMR



Specification

Unit : mm

Model No.	Table Size	Axis	Feed Position	Travel Stroke	Minimum Reading	Straightness Accuracy (μm)	Allowable Loading (kgf)	Weight (kg)	Material	Surface Finish
MC1A-48KM/R	40*80	X-axis	Central	± 30	0.1mm/ Vernier	30	4	0.31	Aluminum alloy	Black anodized

MC1A-48KM

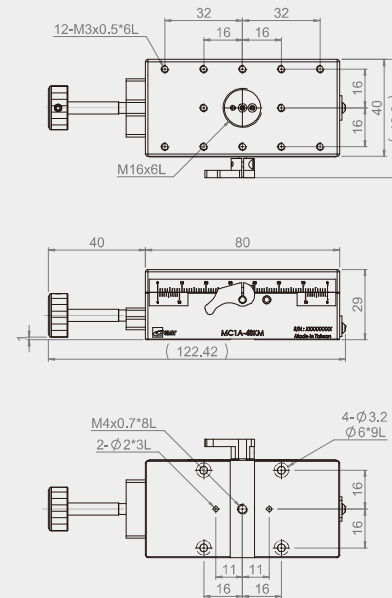

MC1A-48KMR

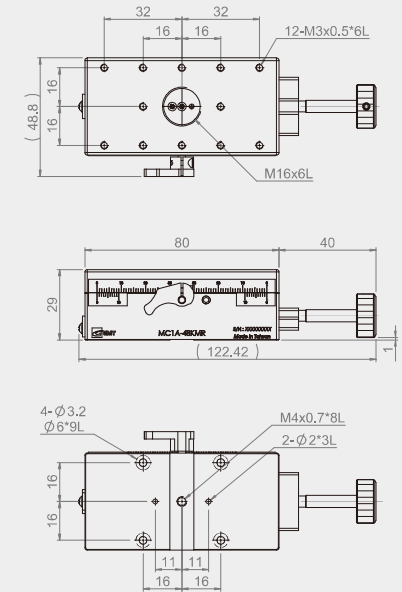

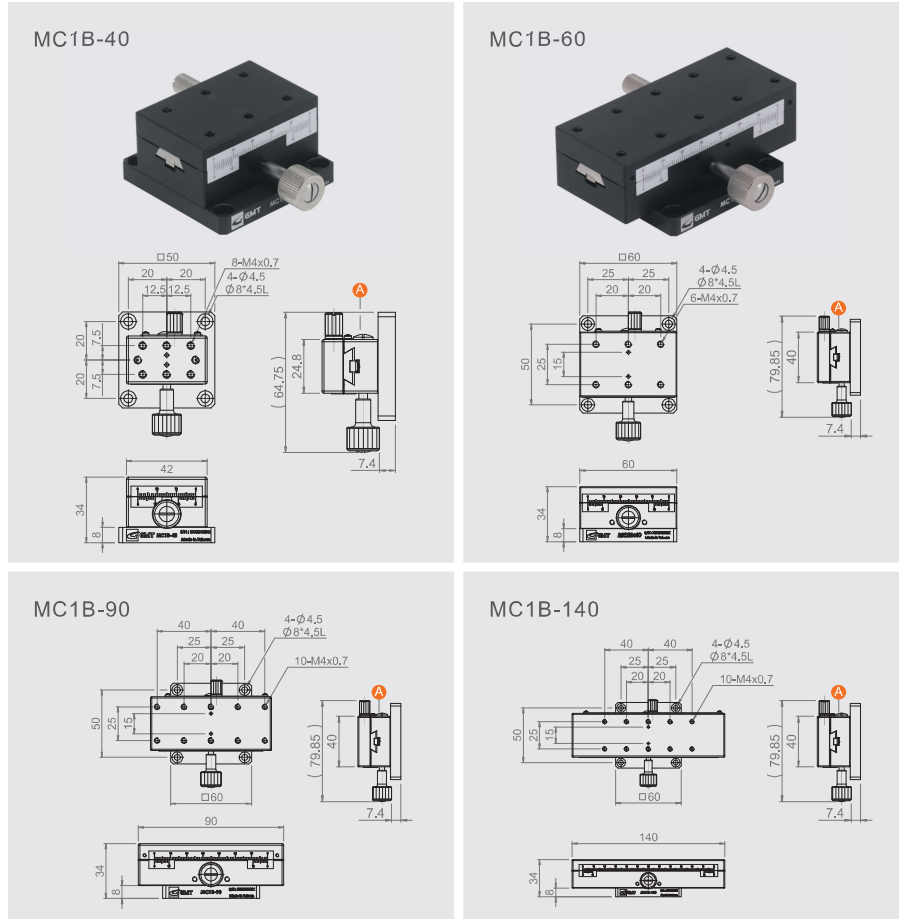

★ Use a flat driver to turn **A** clockwise for slow motion, or turn counterclockwise for smooth motion.

Specification

Unit : mm

Model No.	Table Size	Travel Stroke	Minimum Reading	Straightness Accuracy (µm)	Allowable Loading (kgf)	Weight (kg)	Material	Surface Finish		
MC1B-40	24.8*42	±12	0.1 mm / Vernier	30	3	0.17	Aluminum alloy	Black anodized		
MC1B-60	40*60	±21								
MC1B-90	40*90	±35								
MC1B-140	40*140	±60							4	0.29
					0.56					

★ A full rotation of the feeding screw knob equals a 18mm stroke.

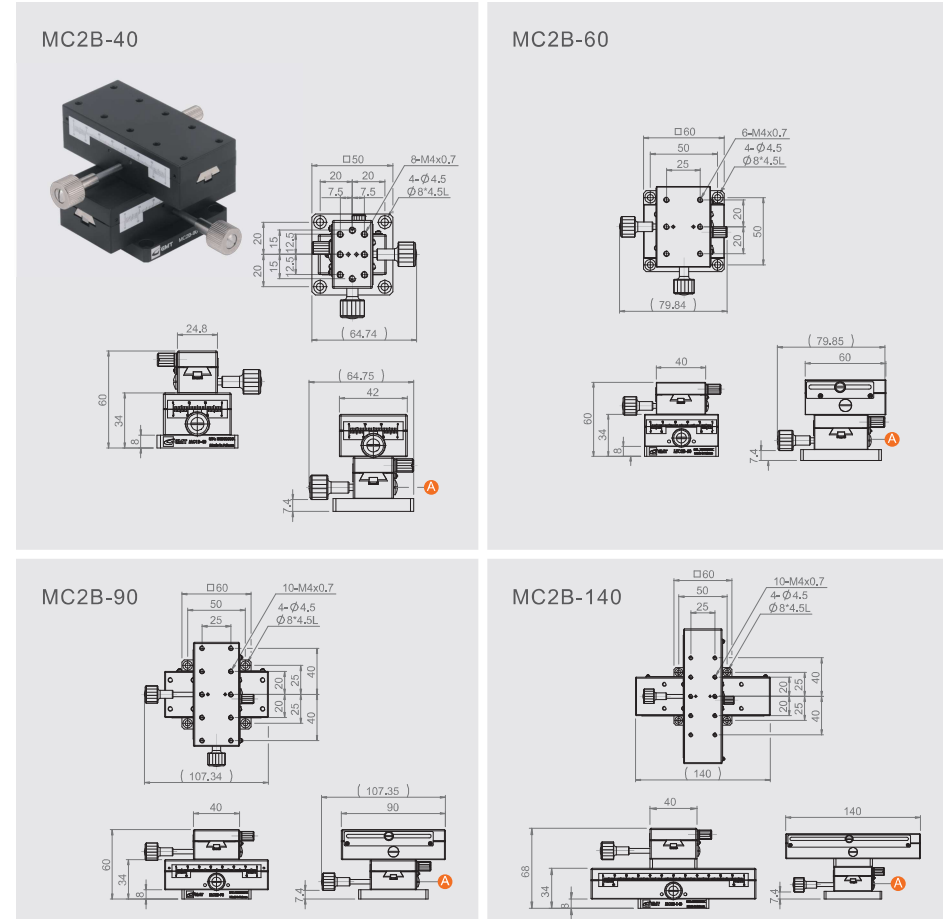

★ Use a flat driver to turn **A** clockwise for slow motion, or turn counterclockwise for smooth motion.

★ Photo shown : MC2B-90 ◦

Specification

Unit : mm

Model No.	Table Size	Travel Stroke	Minimum Reading	Straightness Accuracy (µm)	Allowable Loading (kgf)	Weight (kg)	Material	Surface Finish		
MC2B-40	24.8*42	±12	0.1 mm / Vernier	30	2.5	0.29	Aluminum alloy	Black anodized		
MC2B-60	40*60	±21								
MC2B-90	40*90	±35								
MC2B-140	40*140	±60							3.5	0.51
					1.08					

★ A full rotation of the feeding screw knob equals a 18mm stroke.

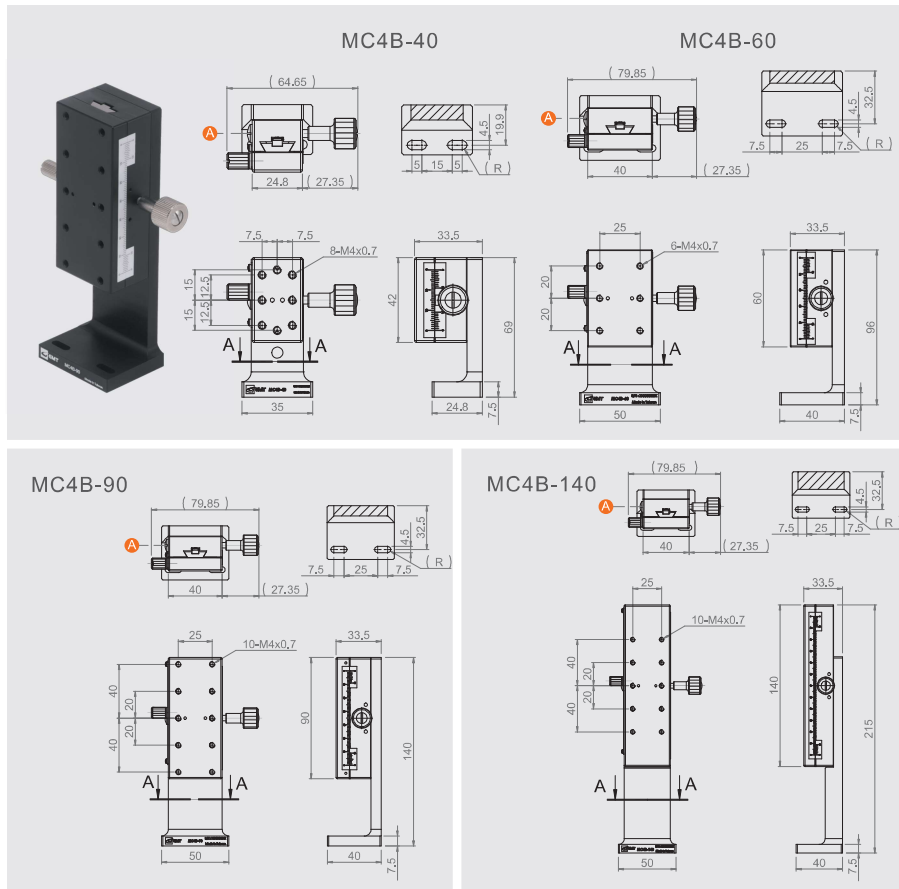

- ★ Use a flat driver to turn **A** clockwise for slow motion, or turn counterclockwise for smooth motion.
- ★ Photo shown : MC4B-90 ◦

Specification

Unit : mm

Model No.	Table Size	Travel Stroke	Minimum Reading	Straightness Accuracy (μm)	Allowable Loading (kgf)	Weight (kg)	Material	Surface Finish
MC4B-40	24.8*42	±12	0.1 mm / Vernier	30	1.5	0.17	Aluminum alloy	Black anodized
MC4B-60	40*60	±21						
MC4B-90	40*90	±35						
MC4B-140	40*140	±60						

- ★ A full rotation of the feeding screw knob equals a 18mm stroke.

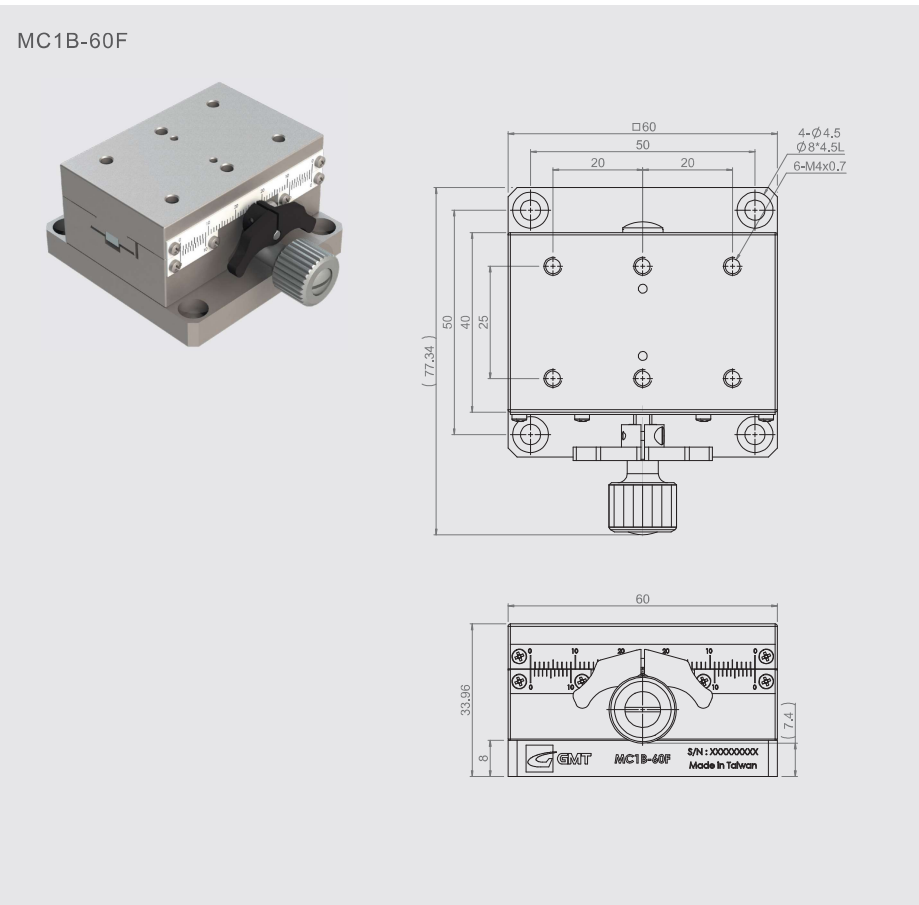

Specification

Unit : mm

Model No.	Table Size	Travel Stroke	Minimum Reading	Straightness Accuracy (μm)	Allowable Loading (kgf)	Weight (kg)	Material	Surface Finish
MC1B-60F	40*60	±21	0.1 mm / Vernier	40	20	1.6	Carbon Steel	Electro-less nickel plating

- ★ A full rotation of the feeding screw knob equals a 18mm stroke.

MC1C-50/70

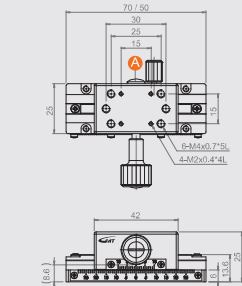
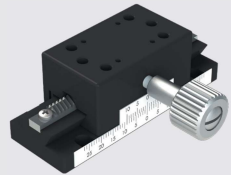

[MC1C-70]

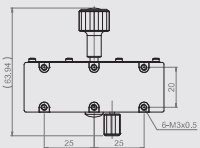

[MC1C-50]

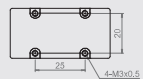

MC1C-100

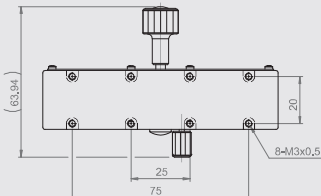
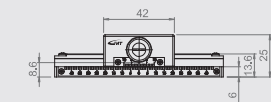
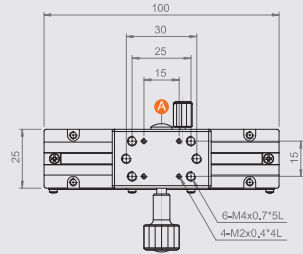

- ★ The upper assembly was set by M2 screws, and the base assembly was set by M3 screws.
- ★ Use a flat driver to turn **A** clockwise for slow motion, or turn counterclockwise for smooth motion.

Specification

Unit : mm

Model No.	Table Size	Travel Stroke	Minimum Reading	Straightness Accuracy (μm)	Allowable Loading (kgf)	Weight (kg)	Material	Surface Finish
MC1C-50	50	±15	0.1 mm / Vernier	30	3	0.12	Aluminum alloy	Black anodized
MC1C-70	70	±25		30				
MC1C-100	100	±40		30				

- ★ A full rotation of the feeding screw knob equals a 18mm stroke.

MC1C-150

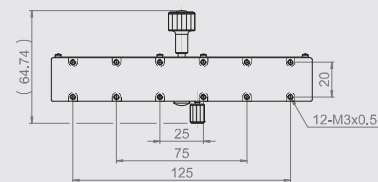
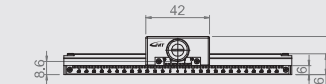
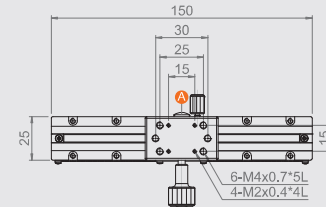
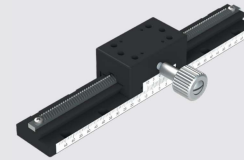

MC1C-200/250

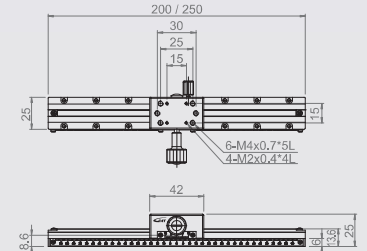

[MC1C-200]

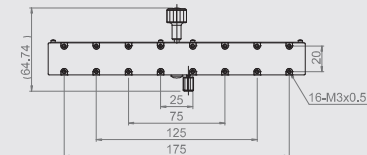

[MC1C-250]

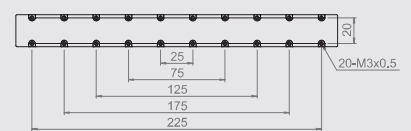

- ★ The upper assembly was set by M2 screws, and the base assembly was set by M3 screws.
- ★ Use a flat driver to turn **A** clockwise for slow motion, or turn counterclockwise for smooth motion.

Specification

Unit : mm

Model No.	Table Size	Travel Stroke	Minimum Reading	Straightness Accuracy (μm)	Allowable Loading (kgf)	Weight (kg)	Material	Surface Finish
MC1C-150	150	±65	0.1 mm / Vernier	40	3	0.17	Aluminum alloy	Black anodized
MC1C-200	200	±90		50		0.21		
MC1C-250	250	±115		50		0.36		

- ★ A full rotation of the feeding screw knob equals a 18mm stroke.

MC1C-150-2

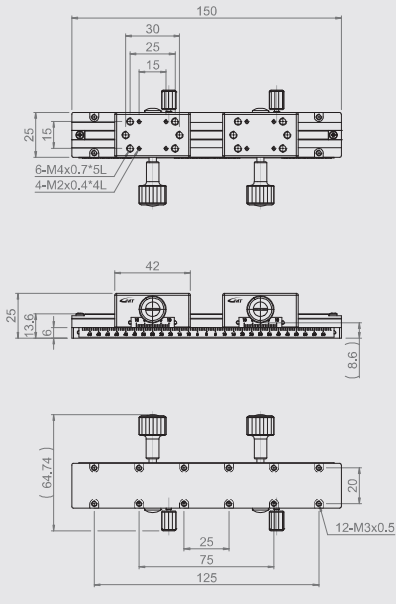
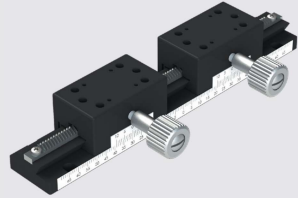

MC1C-200-2

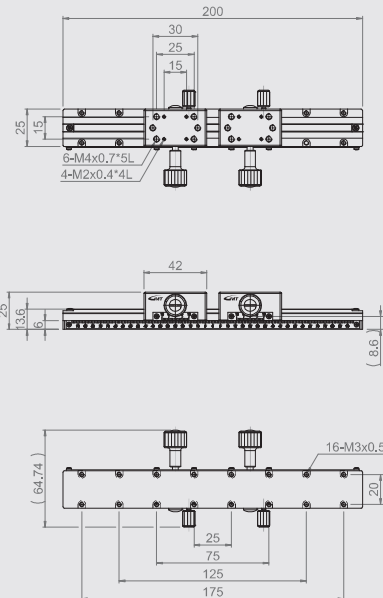

Specification

Unit : mm

Model No.	Table Size	Axis	Travel Stroke	Movement Per Knob Rotation	Minimum Reading	Straightness Accuracy (μm)	Allowable Loading (kgf)	Weight (kg)	Material	Surface Finish	Remarks
MC1C-150-2	150	X-axis	±20	18	0.1 mm / Vernier	40	3	0.24	Aluminum alloy	Black anodized	Two slide blocks
MC1C-200-2	200		±37			50		0.28			

MC1C-300-2

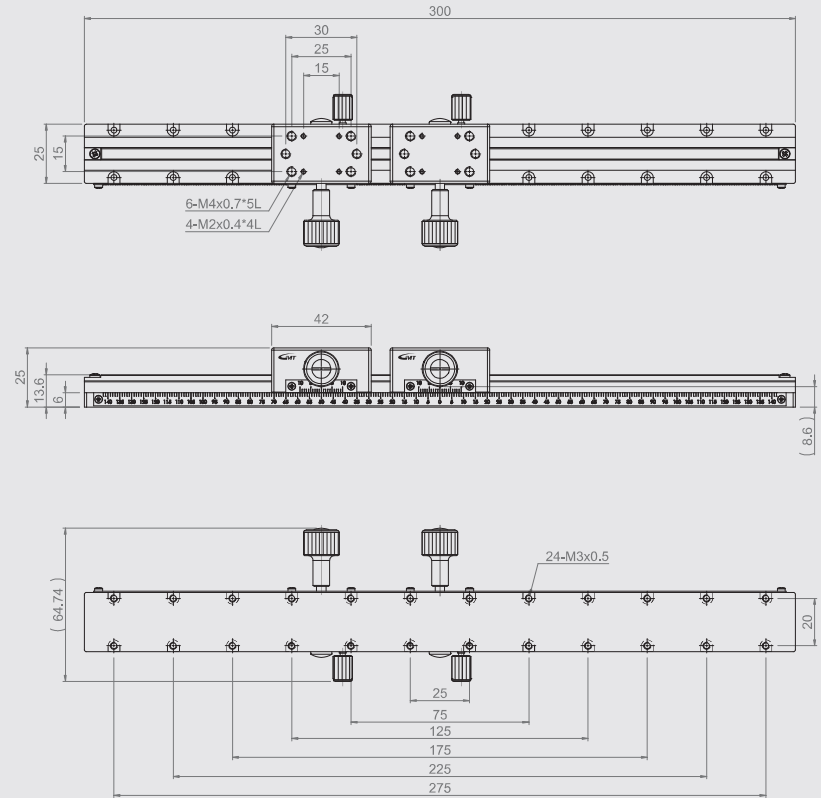

Specification

Unit : mm

Model No.	Table Size	Axis	Travel Stroke	Movement Per Knob Rotation	Minimum Reading	Straightness Accuracy (μm)	Allowable Loading (kgf)	Weight (kg)	Material	Surface Finish	Remarks
MC1C-300-2	300	X-axis	±70	18	0.1 mm / Vernier	70	3	0.35	Aluminum alloy	Black anodized	Two slide blocks

MC3C-100

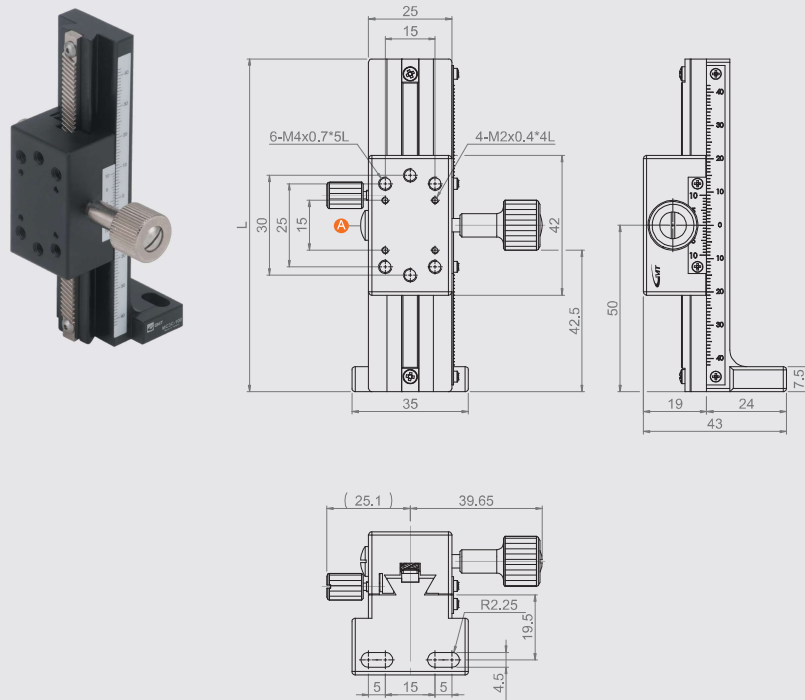

★ Combinble with MC1B (P.149), MC2B(P.150), MC1C(P.153).

★ Use a flat driver to turn **A** clockwise for slow motion, or turn counterclockwise for smooth motion.

Specification

Unit : mm

Model No.	Table Size (L)	Travel Stroke	Minimum Reading	Straightness Accuracy (μm)	Allowable Loading (kgf)	Weight (kg)	Material	Surface Finish
MC3C-50	50	±15	0.1 mm / Vernier	30	1.5	0.12	Aluminum alloy	Black anodized
MC3C-70	70	±25				0.135		
MC3C-100	100	±40				0.16		
MC3C-150	150	±65				0.215		
MC3C-200	200	±90				0.3		
MC3C-250	250	±115				0.36		
MC3C-300	300	±140				0.41		

★ A full rotation of the feeding screw knob equals a 18mm stroke.

MC3C-150-2

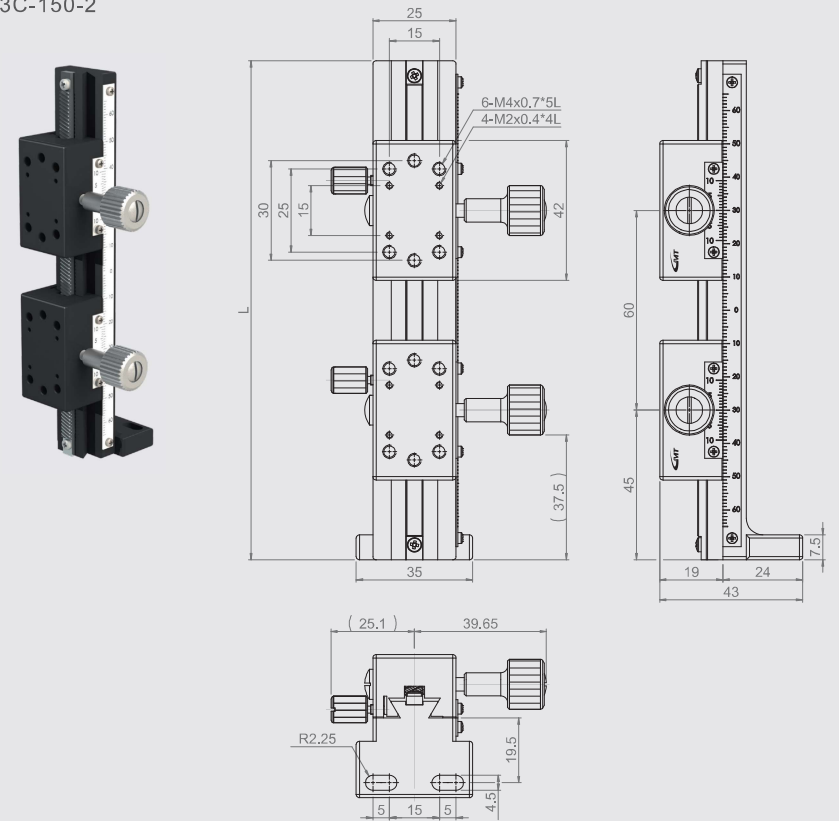

Specification

Unit : mm

Model No.	Table Size (L)	Axis	Travel Stroke	Movement Per Knob Rotation	Minimum Reading	Straightness Accuracy (μm)	Allowable Loading (kgf)	Weight (kg)	Material	Surface Finish	Remarks
MC3C-150-2	150	Z-axis	±20	18	0.1 mm / Vernier	40	3	0.27	Aluminum alloy	Black anodized	Two slide blocks
MC3C-200-2	200		±37			50	1.5	0.3			
MC3C-300-2	300		±70			70	1.5	0.48			

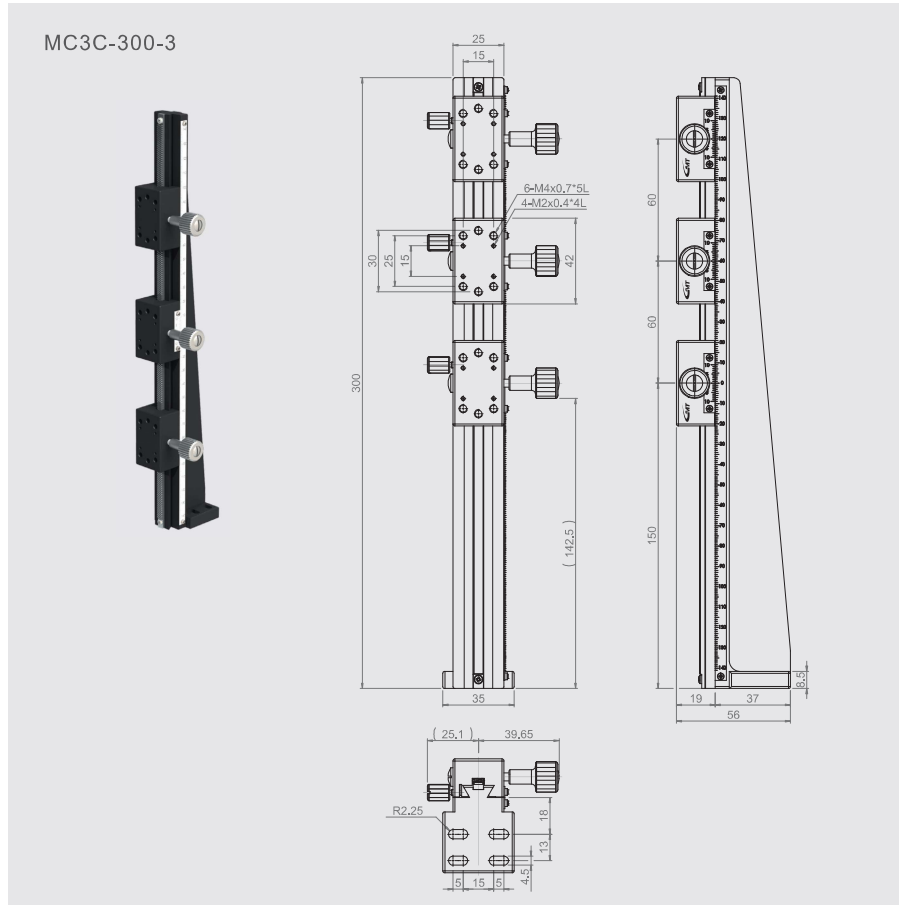

Specification

Unit : mm

Model No.	Table Size	Axis	Travel Stroke	Movement Per Knob Rotation	Minimum Reading	Straightness Accuracy (μm)	Allowable Loading (kgf)	Weight (kg)	Material	Surface Finish	Remarks
MC3C-300-3	300	Z-axis	±43	18	0.1 mm / Vernier	70	1.5	0.55	Aluminum alloy	Black anodized	Three slide blocks

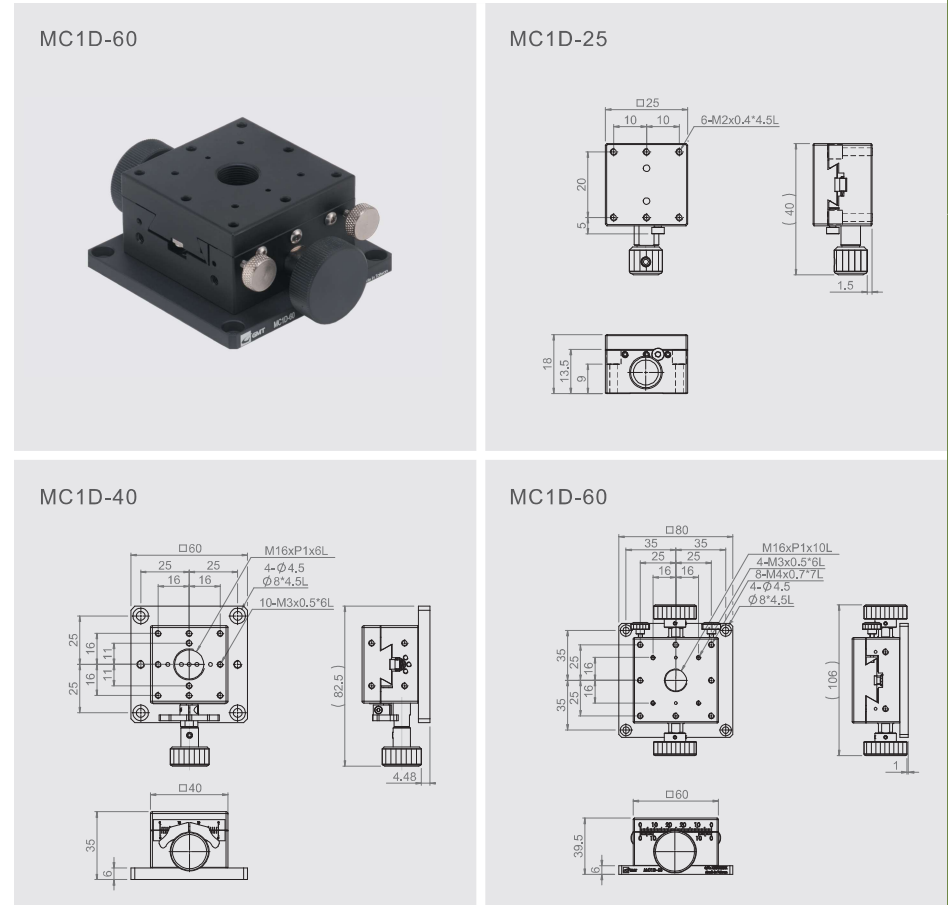

★ The vernier of MC1D-25, MC1D-60 is on the opposite of the mounting surface of the fixture.

Specification

Unit : mm

Model No.	Table Size	Travel Stroke	Movement Per Knob Rotation	Minimum Reading	Straightness Accuracy (μm)	Allowable Loading (kgf)	Weight (kg)	Material	Surface Finish
MC1D-25	25*25	±5	17	0.1 mm / Vernier	20	3	0.09	Brass alloy	Black fluororesin finished
MC1D-40	40*40	±10	20		20				
MC1D-60	60*60	±20	18		30	4	0.64	Aluminum alloy	Black anodized

MC2D-60



MC2D-25

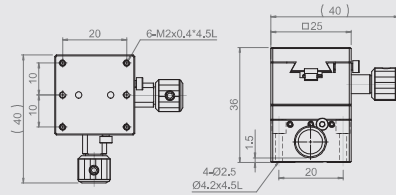

MC2D-40

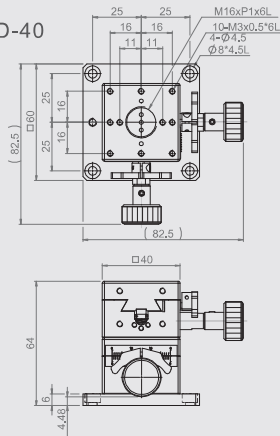

MC2D-60

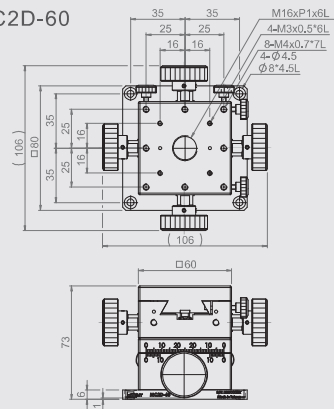

MC4D-60



MC4D-25

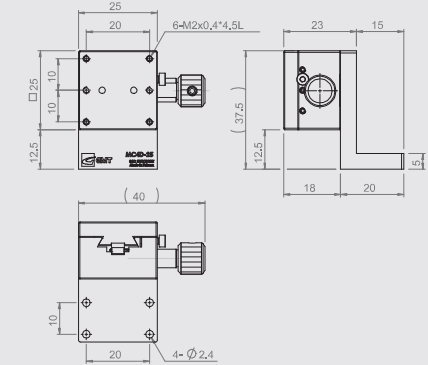

MC4D-40

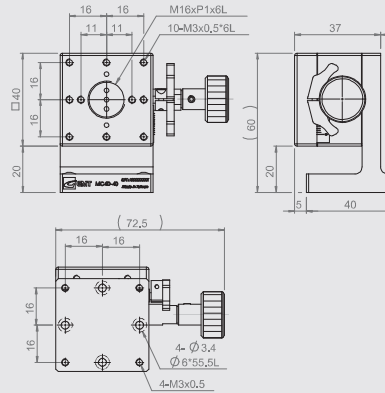

MC4D-60

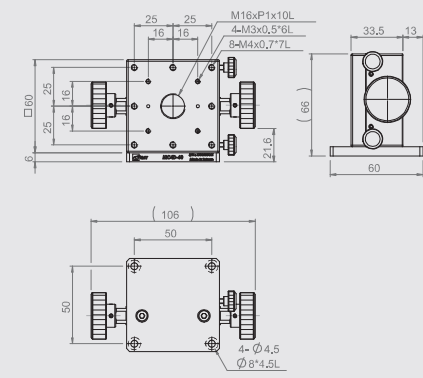

★ The vernier of MC4D-25 is on the opposite of the mounting surface of the fixture.

Specification

Unit : mm

Model No.	Table Size	Travel Stroke	Movement Per Knob Rotation	Minimum Reading	Straightness Accuracy (µm)	Allowable Loading (kgf)	Weight kg	Material	Surface Finish
MC2D-25	25*25	±5	17	0.1 mm / Vernier	20	2.9	0.18	Brass alloy	Black fluororesin finished
MC2D-40	40*40	±10	20		20	2.8	0.37	Aluminum alloy	Black anodized
MC2D-60	60*60	±20	18		30	3	1.19		

Specification

Unit : mm

Model No.	Table Size	Travel Stroke	Movement Per Knob Rotation	Minimum Reading	Straightness Accuracy (µm)	Allowable Loading (kgf)	Weight kg	Material	Surface Finish
MC4D-25	25*25	±5	17	0.1 mm / Vernier	20	0.7	0.11	Brass alloy	Black fluororesin finished
MC4D-40	40*40	±10	20		20	1.5	0.23	Aluminum alloy	Black anodized
MC4D-60	60*60	±20	18		30	2	0.60		

MC1D-40L

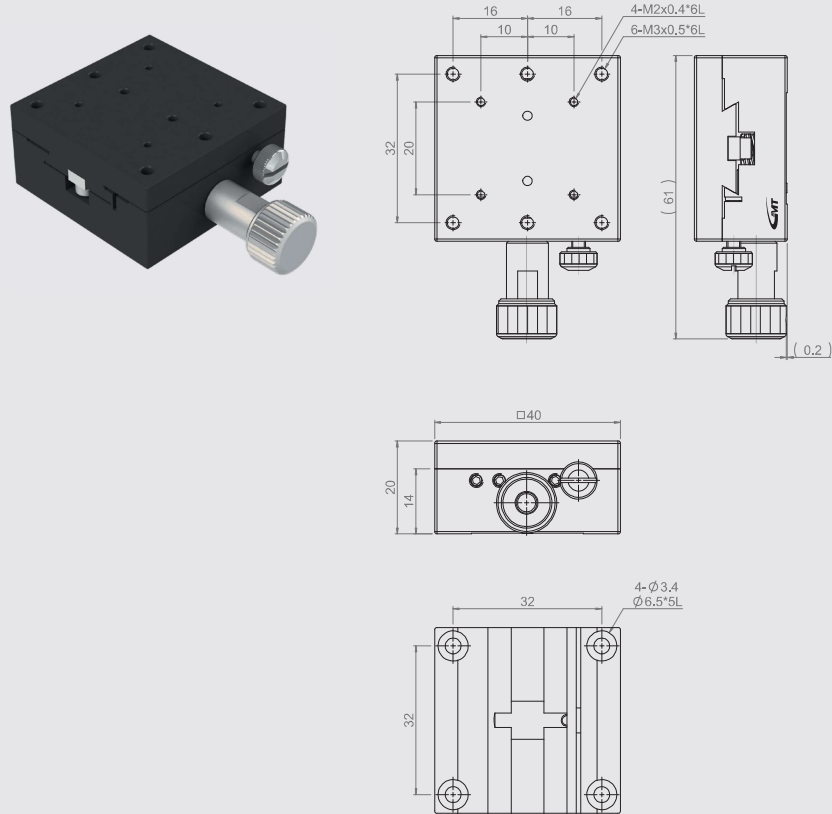

Specification

Unit : mm

Model No.	Table Size	Axis	Travel Stroke	Movement Per Knob Rotation	Straightness Accuracy (μm)	Allowable Loading (kgf)	Weight kg	Material	Surface Finish
MC1D-40L	40*40	X-axis	±10	20	30	2	0.25	Aluminum alloy	Black fluororesin finished

MC2DA-48NH

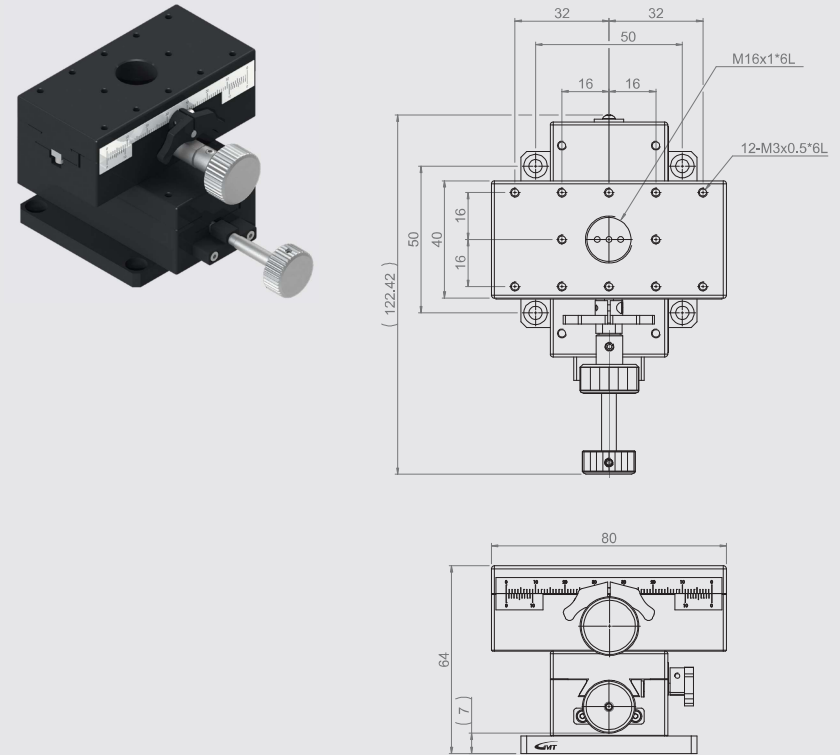

Specification

Unit : mm

Model No.	Table Size	Axis	Travel Stroke	Movement Per Knob Rotation	Minimum Reading	Straightness Accuracy (μm)	Allowable Loading (kgf)	Weight kg	Material	Surface Finish
MC2DA-48NH	40*80(upper)	Y-axis	±35	18	0.1 mm / Vernier	30	3	0.6	Aluminum alloy	Black anodized
	40*80(lower)	X-axis	±30	42						

MC3B-40



MC3B-25

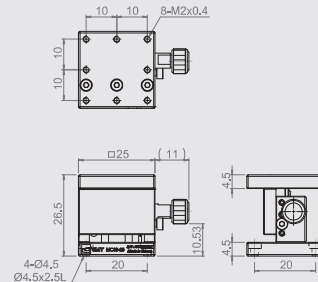

MC3B-40

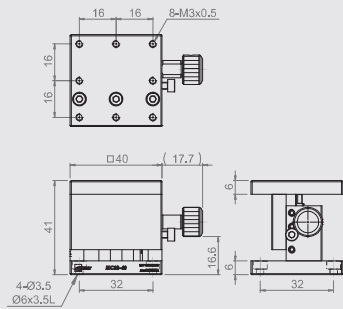

MC3B-60

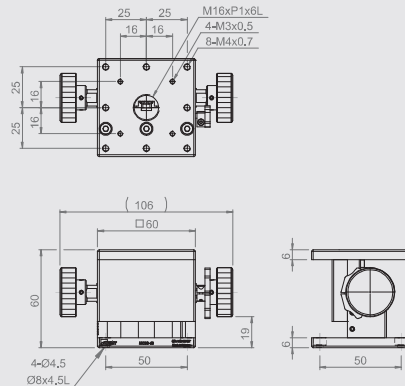

Specification

Unit : mm

Model No.	Table Size	Travel Stroke	Movement Per Knob Rotation	Minimum Reading	Straightness Accuracy (μm)	Allowable Loading (kgf)	Weight kg	Material	Surface Finish
MC3B-25	25*25	±2.5	≒ 8	0.1 mm / Vernier	30	0.7	0.08	Brass alloy	Black fluororesin finished
MC3B-40	40*40	±5	≒ 13			1	0.12		
MC3B-60	60*60	±10	≒ 18			1.5	0.47	Aluminum alloy	

★ The Vernier is on the opposite side of the mounting surface of the fixture.

MC5B-40



MC5B-25

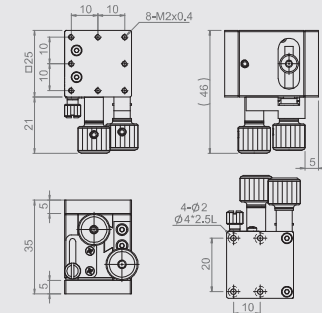

MC5B-40

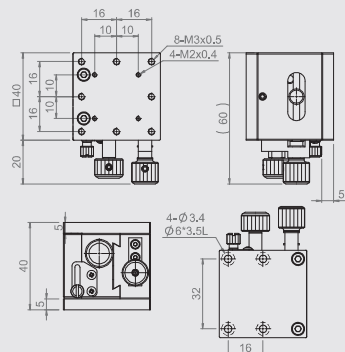

MC5B-60

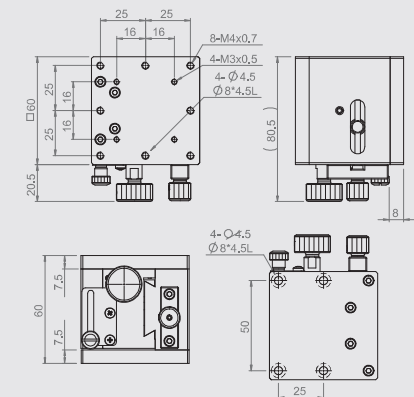

Specification

Unit : mm

Model No.	Table Size	Travel Stroke	Movement Per Knob Rotation	Straightness Accuracy (μm)	Allowable Loading (kgf)	Weight kg	Material	Surface Finish
MC5B-25	25*25	X: ±5 Z: +10	X: 0.5 Z: ≒ 14	30	1	0.17	Brass alloy	Black fluororesin finished
MC5B-40	40*40	X: ±7 Z: +10	X: 0.5 Z: ≒ 14			0.51		
MC5B-60	60*60	X: ±10 Z: +25	X: 0.5 Z: ≒ 20			0.62	Aluminum alloy	

MC1BL-60

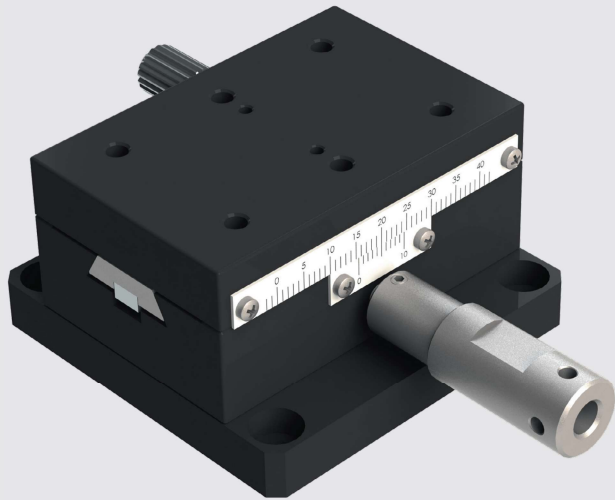

Specification

Unit : mm

Model No.	Table Size	Axis	Travel Stroke	Movement Per Knob Rotation	Minimum Reading	Straightness Accuracy (μm)	Allowable Loading (kgf)	Weight kg	Material	Surface Finish
MC1BL-60	40*60	X-axis	±21	18	0.1 mm / Vernier	30	3	0.3	Aluminum alloy	Black anodized

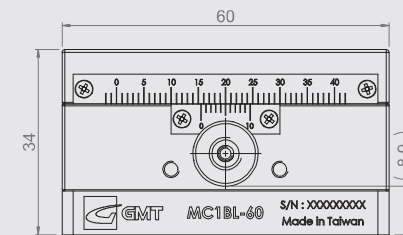
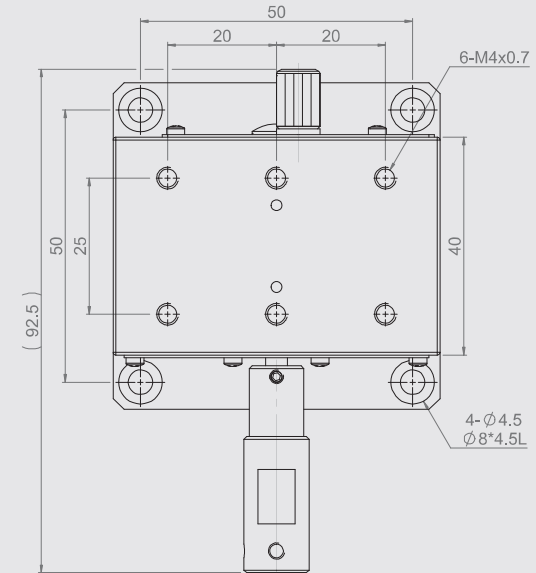

MCS-44

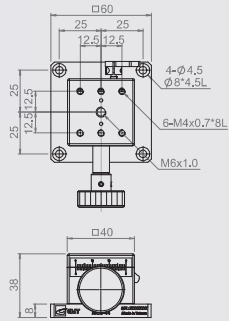

MCS-44

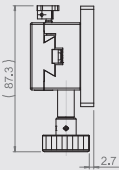

MCS-44W

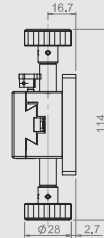

MCS-46

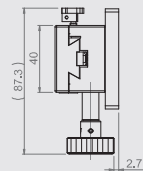
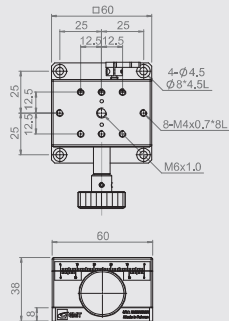

MCS-46W

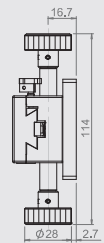

Specification

Unit : mm

Model No.	Table Size	Axis	Knob Type	Travel Stroke	Minimum Reading	Straightness Accuracy (μm)	Allowable Loading (kgf)	Weight kg	Material	Surface Finish
MCS-44	40*40	X-axis	Single	±10	0.1 mm / Vernier	30	4	0.24	Aluminum alloy	Black anodized
MCS-44W			Dual					0.27		
MCS-46	40*60		Single	±15				0.31		
MCS-46W			Dual					0.33		

★ The Vernier is on the opposite side of the mounting surface of the fixture.

MCS-49

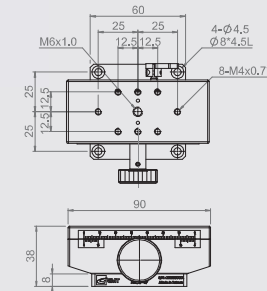

MCS-49

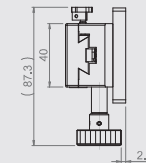

MCS-49W

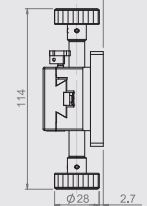

MCS-41

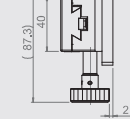
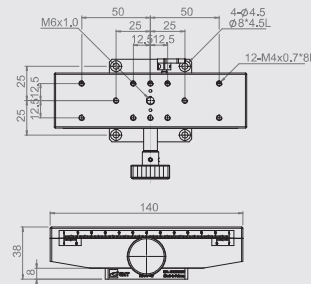

MCS-41W

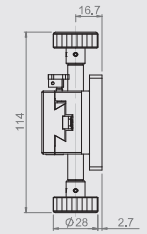

Specification

Unit : mm

Model No.	Table Size	Axis	Knob Type	Travel Stroke	Minimum Reading	Straightness Accuracy (μm)	Allowable Loading (kgf)	Weight kg	Material	Surface Finish
MCS-49	40*90	X-axis	Single	±30	0.1 mm / Vernier	30	4	0.4	Aluminum alloy	Black anodized
MCS-49W			Dual					0.42		
MCS-41	40*140		Single	±50				0.55		
MCS-41W			Dual					0.58		

MCV-44

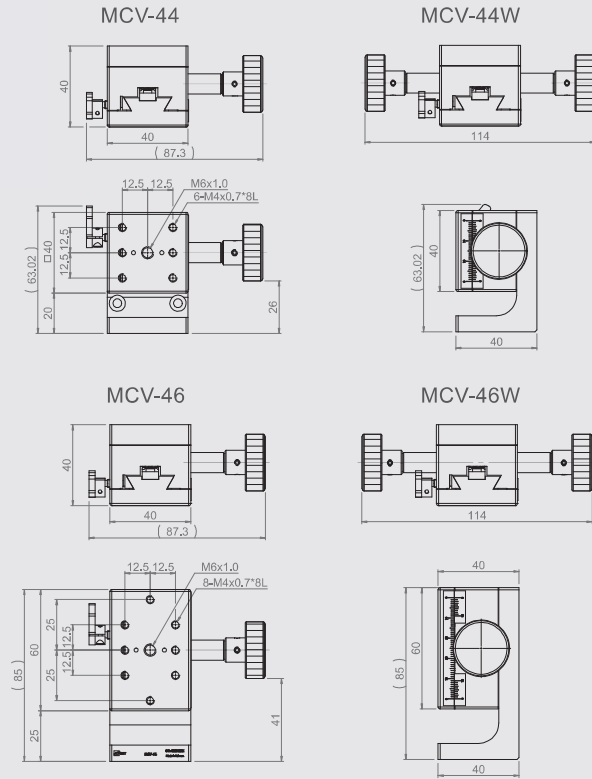

Specification

Unit : mm

Model No.	Table Size	Axis	Knob Type	Travel Stroke	Minimum Reading	Straightness Accuracy (μm)	Allowable Loading (kgf)	Weight (kg)	Material	Surface Finish
MCV-44	40*40	Z-axis	Single	±10	0.1 mm / Vernier	30	2	0.26	Aluminum alloy	Black anodized
MCV-44W			Dual					0.28		
MCV-46	Single		±15	0.36						
MCV-46W	Dual			0.38						

MCV-49

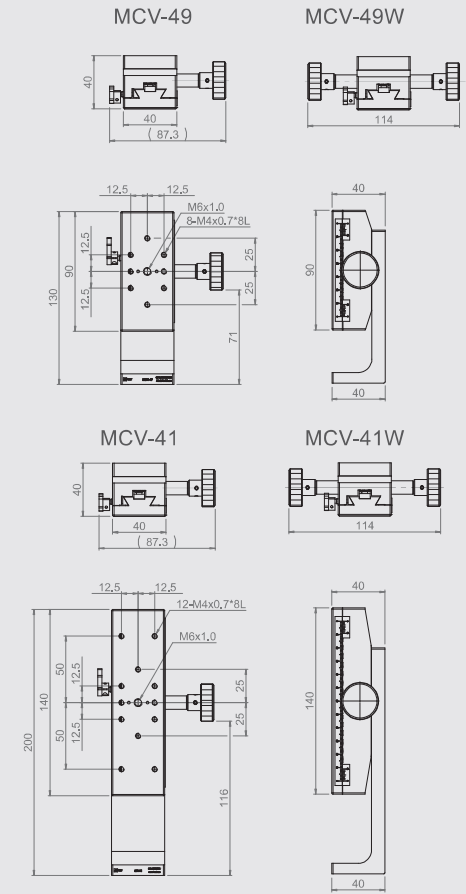

Specification

Unit : mm

Model No.	Table Size	Axis	Knob Type	Travel Stroke	Minimum Reading	Straightness Accuracy (μm)	Allowable Loading (kgf)	Weight (kg)	Material	Surface Finish
MCV-49	40*90	Z-axis	Single	±30	0.1 mm / Vernier	30	2	0.47	Aluminum alloy	Black anodized
MCV-49W			Dual					0.5		
MCV-41	Single		±50	0.67						
MCV-41W	Dual			0.7						

MCV-44L

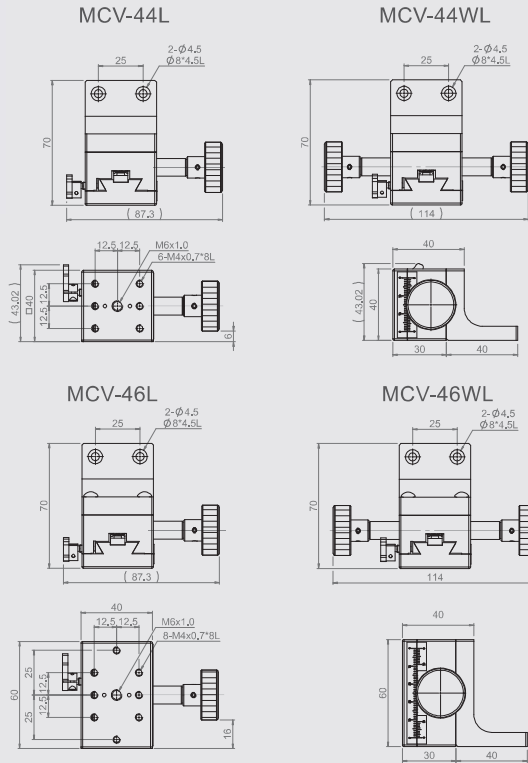

Specification

Unit : mm

Model No.	Table Size	Axis	Knob Type	Travel Stroke	Minimum Reading	Straightness Accuracy (μm)	Allowable Loading (kgf)	Weight (kg)	Material	Surface Finish
MCV-44L	40*40	Z-axis	Single	±10	0.1 mm / Vernier	30	2	0.23	Aluminum alloy	Black anodized
MCV-44WL			Dual					0.26		
MCV-46L	Single		±15	0.33						
MCV-46WL	Dual			0.35						

MCV-49L

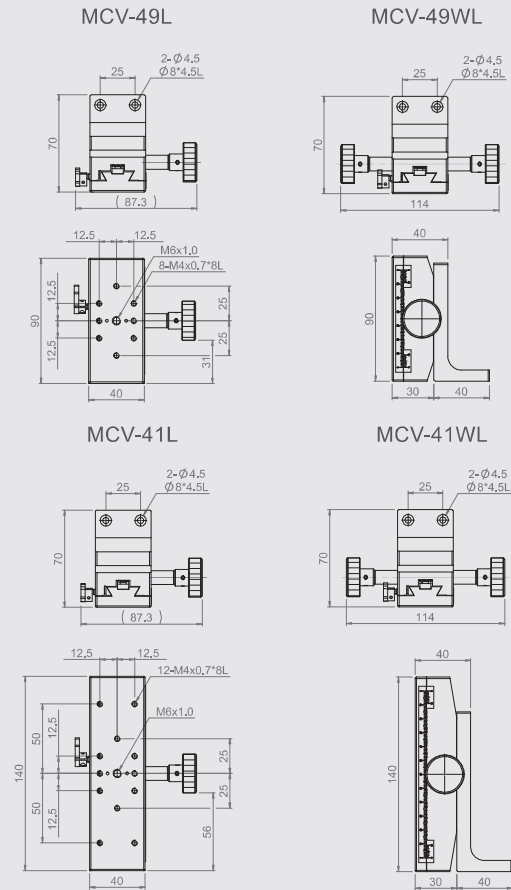

Specification

Unit : mm

Model No.	Table Size	Axis	Knob Type	Travel Stroke	Minimum Reading	Straightness Accuracy (μm)	Allowable Loading (kgf)	Weight (kg)	Material	Surface Finish
MCV-49L	40*90	Z-axis	Single	±30	0.1 mm / Vernier	30	2	0.45	Aluminum alloy	Black anodized
MCV-49WL			Dual					0.47		
MCV-41L	40*140		Single	±50				0.63		
MCV-41WL			Dual					0.66		

MCM-44

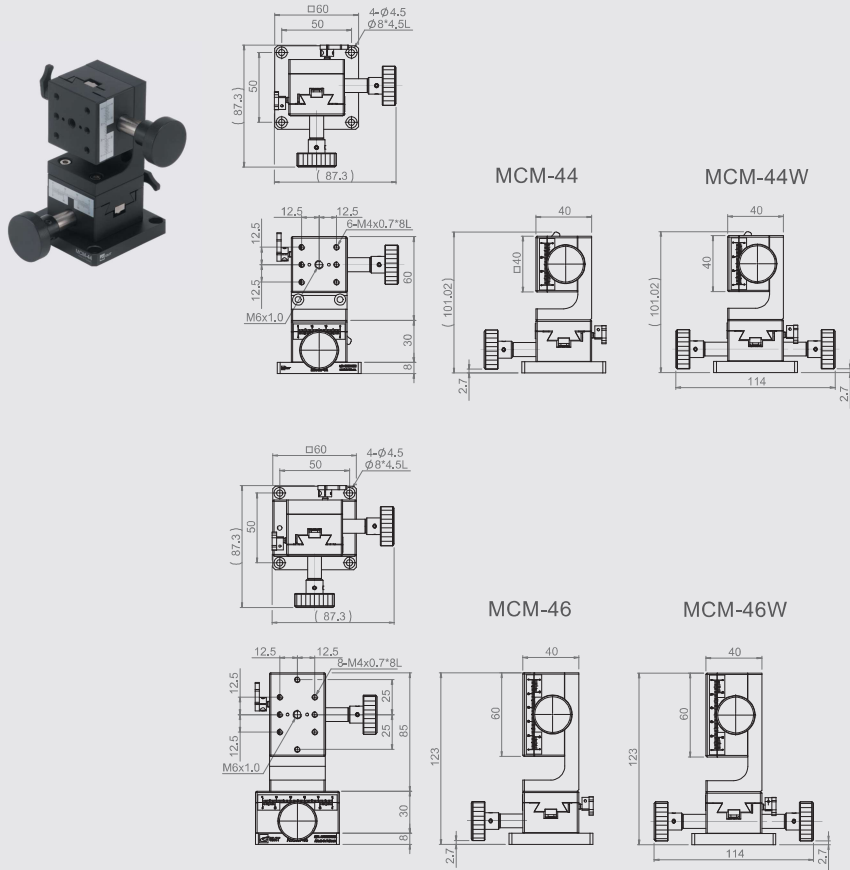

Specification

Unit : mm

Model No.	Table Size	Axis	Knob Type	Travel Stroke	Minimum Reading	Straightness Accuracy (μm)	Allowable Loading (kgf)	Weight (kg)	Material	Surface Finish
MCM-44	40*40	X+Z axis	Single	±10	0.1 mm / Vernier	30	2	0.5	Aluminum alloy	Black anodized
MCM-44W			Dual					0.55		
MCM-46	40*60		Single	±15				0.67		
MCM-46W			Dual					0.72		

MCM-49

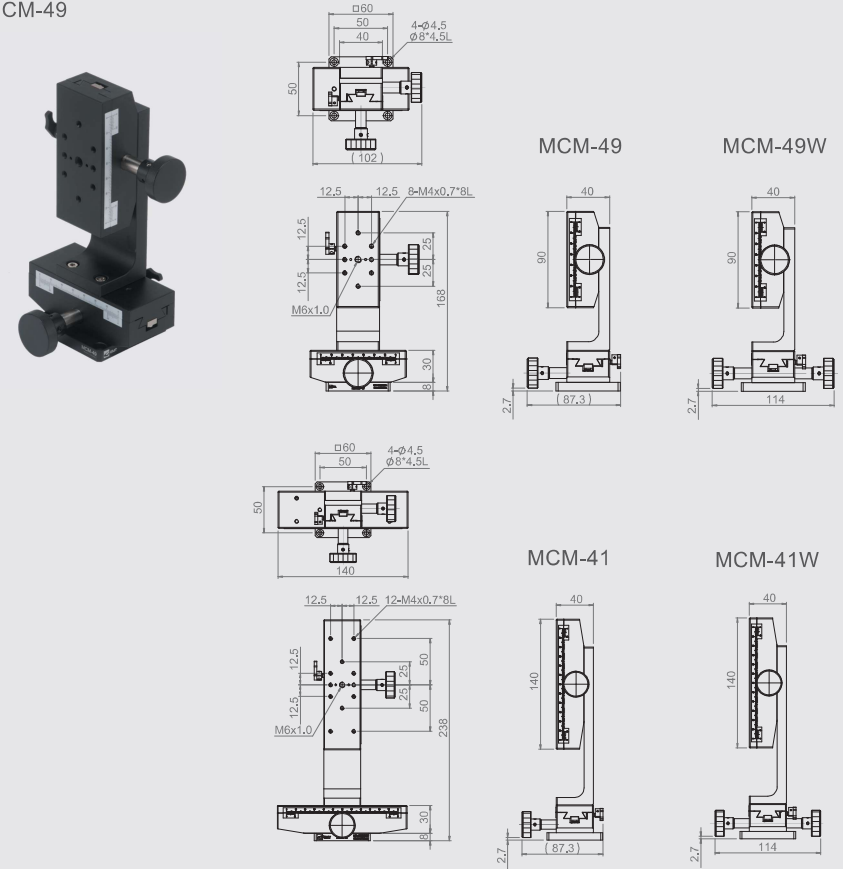

Specification

Unit : mm

Model No.	Table Size	Axis	Knob Type	Travel Stroke	Minimum Reading	Straightness Accuracy (μm)	Allowable Loading (kgf)	Weight (kg)	Material	Surface Finish
MCM-49	40*90	X+Z axis	Single	±30	0.1 mm / Vernier	30	2	0.87	Aluminum alloy	Black anodized
MCM-49W			Dual					0.92		
MCM-41	40*140		Single	±50				1.23		
MCM-41W			Dual					1.28		

MCM-44L

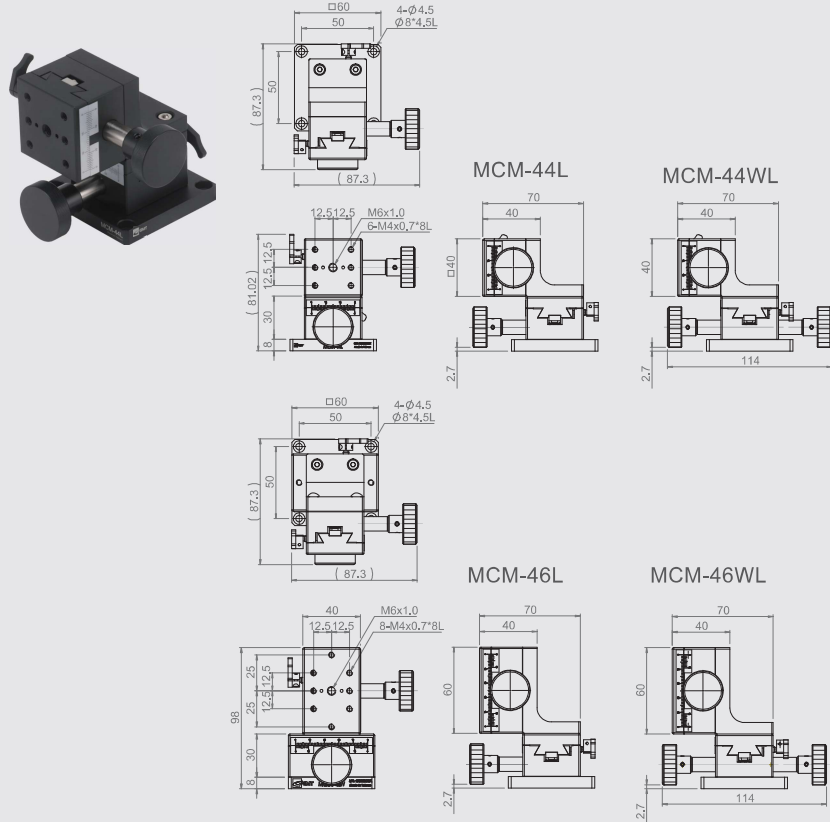

Specification

Unit : mm

Model No.	Table Size	Axis	Knob Type	Travel Stroke	Minimum Reading	Straightness Accuracy (μm)	Allowable Loading (kgf)	Weight (kg)	Material	Surface Finish
MCM-44L	40*40	X+Z axis	Single	X: ±10 Z: 10	0.1 mm / Vernier	30	2	0.47	Aluminum alloy	Black anodized
MCM-44WL			Dual					0.52		
MCM-46L	40*60		Single	X: ±15 Z: 15				0.64		
MCM-46WL			Dual					0.68		

MCM-49L

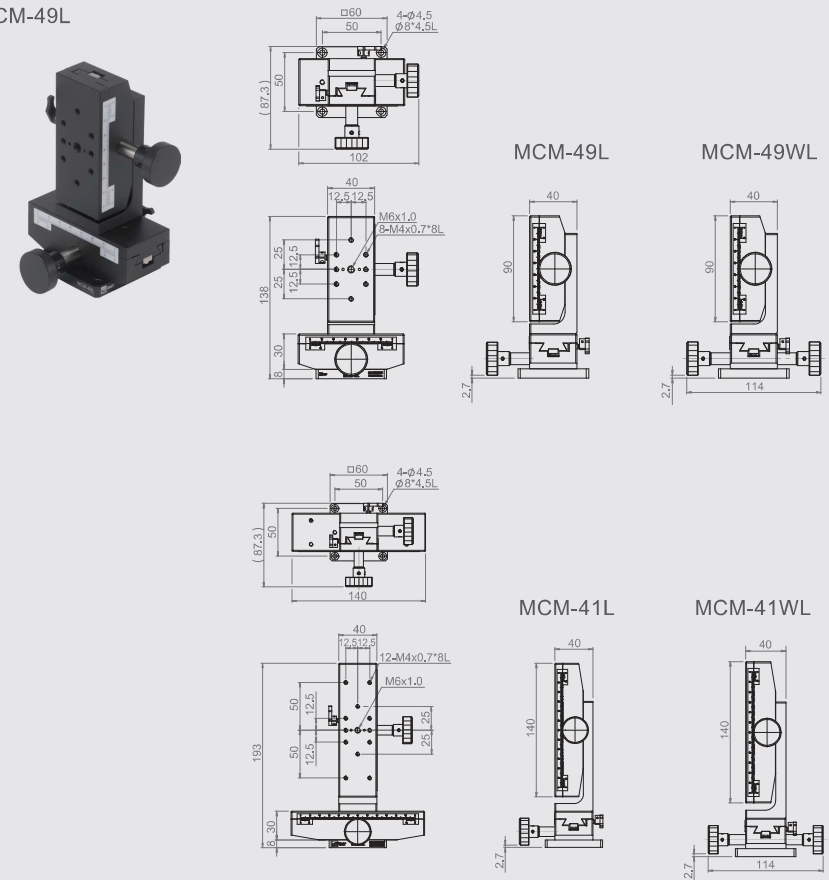

Specification

Unit : mm

Model No.	Table Size	Axis	Knob Type	Travel Stroke	Minimum Reading	Straightness Accuracy (μm)	Allowable Loading (kgf)	Weight (kg)	Material	Surface Finish
MCM-49L	40*90	X+Z axis	Single	X: ±30 Z: 30	0.1 mm / Vernier	30	2	0.85	Aluminum alloy	Black anodized
MCM-49WL			Dual					0.89		
MCM-41L	40*140		Single	X: ±50 Z: 50				1.18		
MCM-41WL			Dual					1.24		

MCT-44

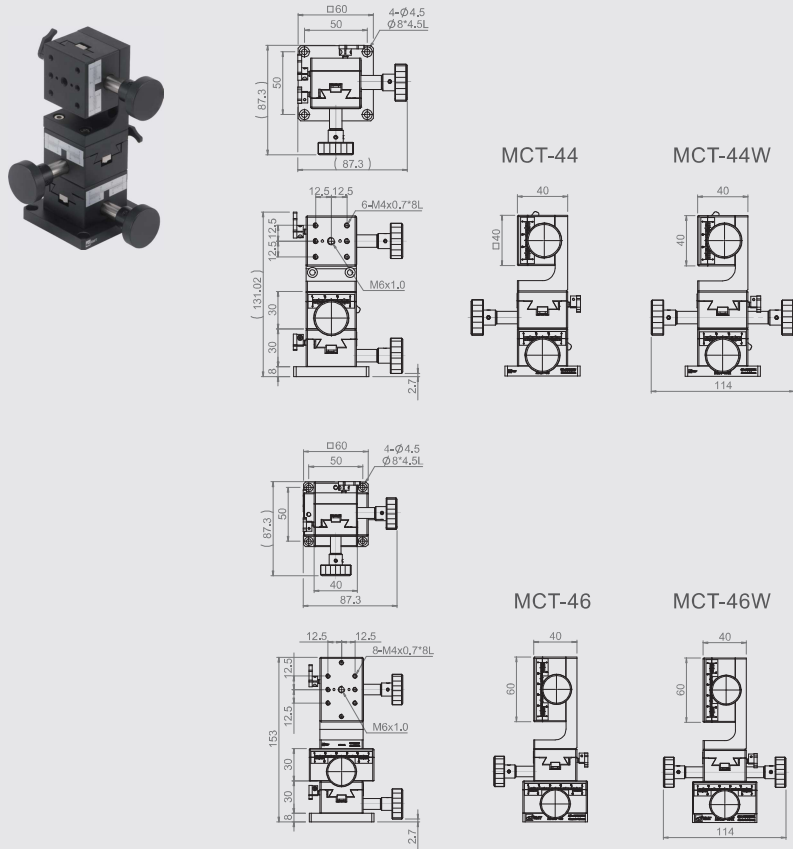

Specification

Unit : mm

Model No.	Table Size	Axis	Knob Type	Travel Stroke	Minimum Reading	Straightness Accuracy (μm)	Allowable Loading (kgf)	Weight (kg)	Material	Surface Finish
MCT-44	40*40	XY+Z axis	Single	±10	0.1 mm / Vernier	30	2	0.67	Aluminum alloy	Black anodized
MCT-44W			Dual					0.74		
MCT-46	40*60		Single	±15				0.9		
MCT-46W			Dual					0.98		

MCT-49

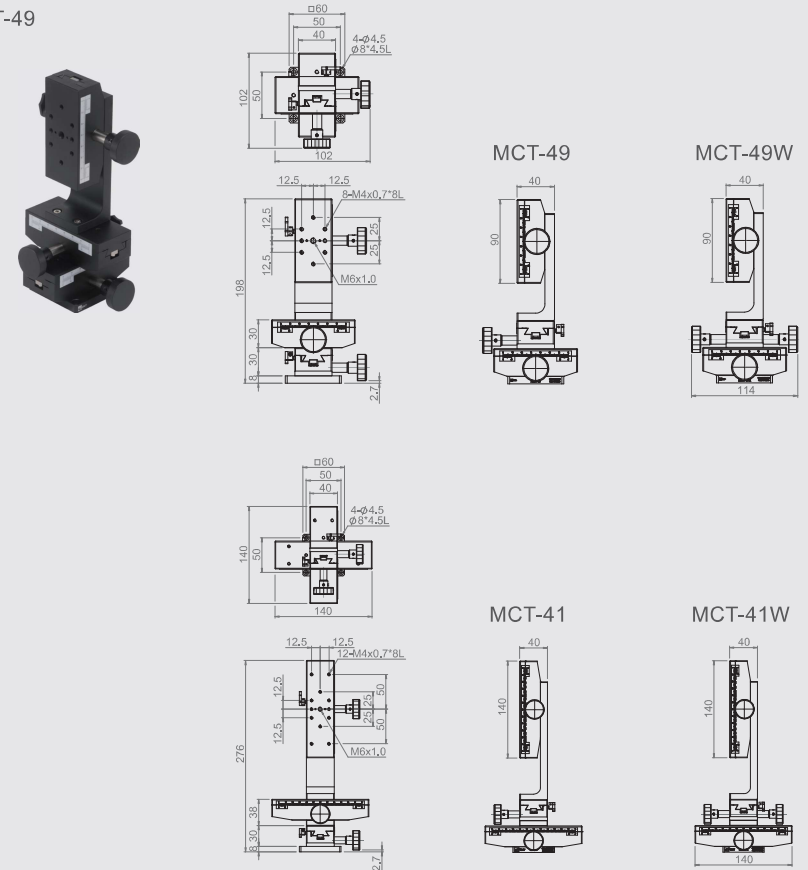

Specification

Unit : mm

Model No.	Table Size	Axis	Knob Type	Travel Stroke	Minimum Reading	Straightness Accuracy (μm)	Allowable Loading (kgf)	Weight (kg)	Material	Surface Finish
MCT-49	40*90	XY+Z axis	Single	±30	0.1 mm / Vernier	30	2	1.2	Aluminum alloy	Black anodized
MCT-49W			Dual					1.27		
MCT-41	40*140		Single	±50				1.74		
MCT-41W			Dual					1.82		

MCT-44L

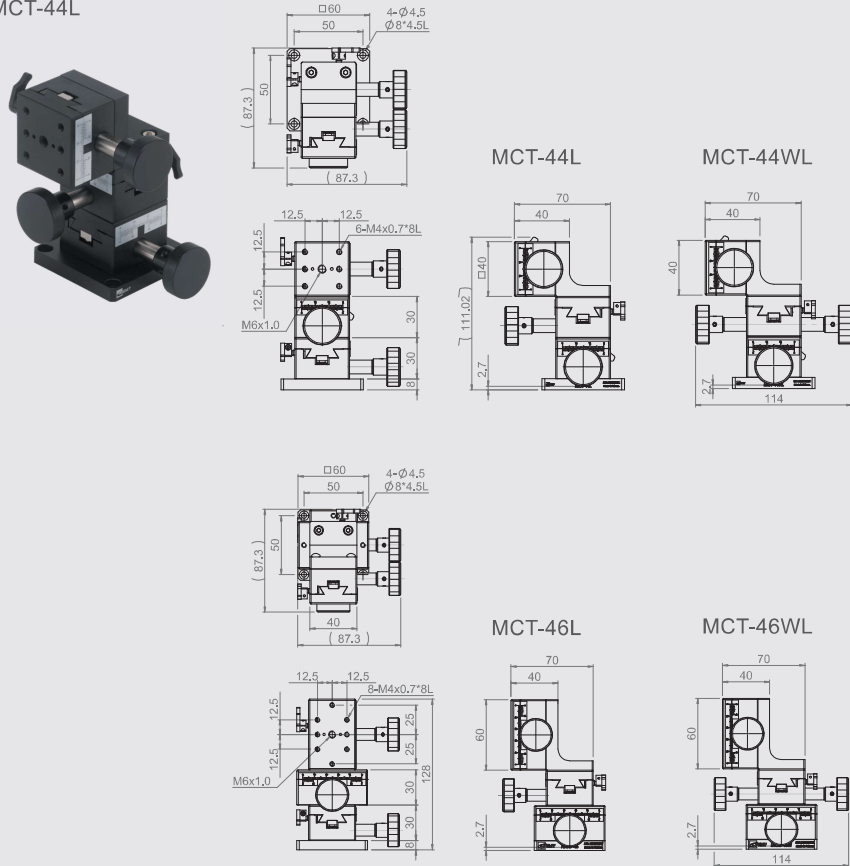

Specification

Unit : mm

Model No.	Table Size	Axis	Knob Type	Travel Stroke	Minimum Reading	Straightness Accuracy (μm)	Allowable Loading (kgf)	Weight (kg)	Material	Surface Finish
MCT-44L	40*40	XY+Z axis	Single	XY: ±10 Z: 10	0.1 mm / Vernier	30	2	0.64	Aluminum alloy	Black anodized
MCT-44WL			Dual					0.72		
MCT-46L	40*60	XY+Z axis	Single	XY: ±15 Z: 15	0.1 mm / Vernier	30	2	0.87	Aluminum alloy	Black anodized
MCT-46WL			Dual					0.94		

MCT-49L

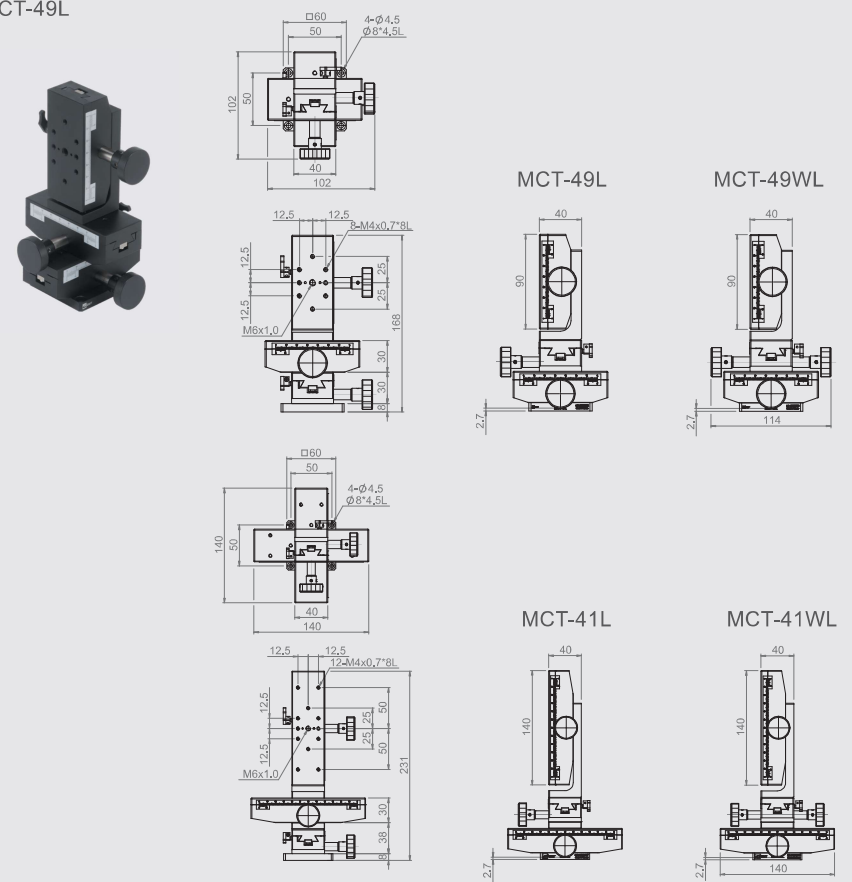

Specification

Unit : mm

Model No.	Table Size	Axis	Knob Type	Travel Stroke	Minimum Reading	Straightness Accuracy (μm)	Allowable Loading (kgf)	Weight (kg)	Material	Surface Finish
MCT-49L	40*90	XY+Z axis	Single	XY: ±30 Z: 30	0.1 mm / Vernier	30	2	1.17	Aluminum alloy	Black anodized
MCT-49WL			Dual					1.24		
MCT-41L	40*140	XY+Z axis	Single	XY: ±50 Z: 50	0.1 mm / Vernier	30	2	1.7	Aluminum alloy	Black anodized
MCT-41WL			Dual					1.78		

MC1E-60



MC2E-60



Specification

Unit : mm

Model No.	Table Size	Axis	Travel Stroke	Minimum Reading	Straightness (μm)	Allowable Loading (kgf)	Weight (kg)	Material	Surface Finish
MC1E-25	25*25	X-axis	±3	No Scale	30	3	0.07	Brass alloy	Black fluororesin finished
MC1E-40	40*40		±5			3	0.19		
MC1E-60	60*60		±7			4	0.6		
MC2E-25	25*25	XY-axis	±3			2.9	0.15		
MC2E-40	40*40		±5			2.8	0.38		
MC2E-60	60*60		±7			3.4	1.2		

MC1E-25

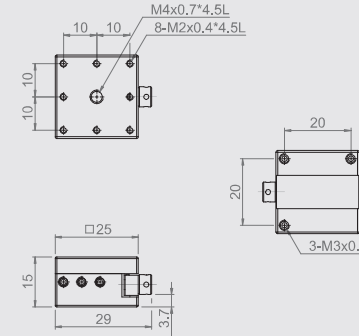

MC2E-25

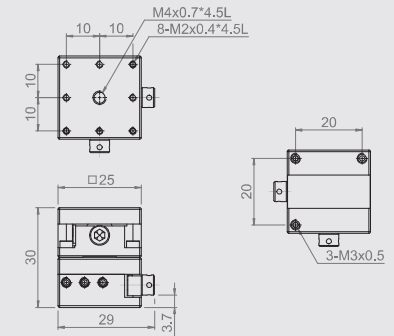

MC1E-40

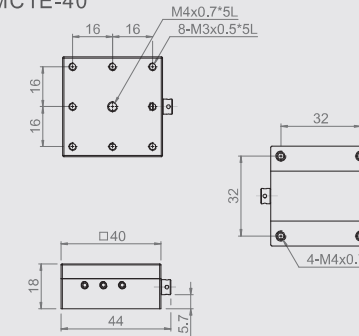

MC2E-40

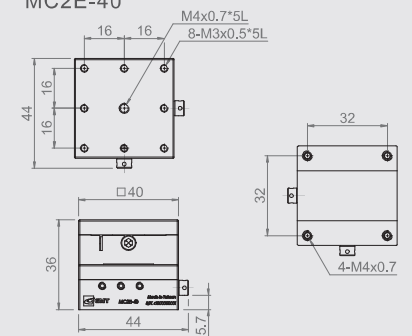

MC1E-60

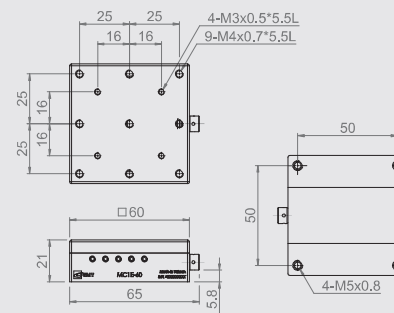

MC2E-60

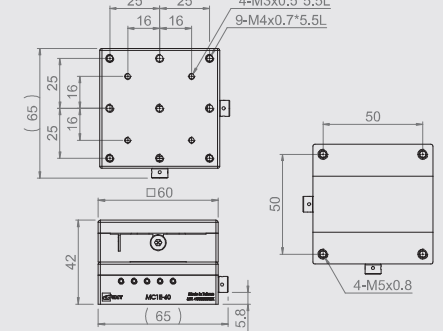

MC4E-60



Specification

Unit : mm

Model No.	Table Size	Axis	Travel Stroke	Minimum Reading	Straightness (μm)	Allowable Loading (kgf)	Weight (kg)	Material	Surface Finish
MC4E-25	25*25	Z-axis	±3	No Scale	30	1	0.08	Brass alloy	Black fluororesin finished
MC4E-40	40*40		±5			1	0.27		
MC4E-60	60*60		±7			2	0.65		

MC4E-25

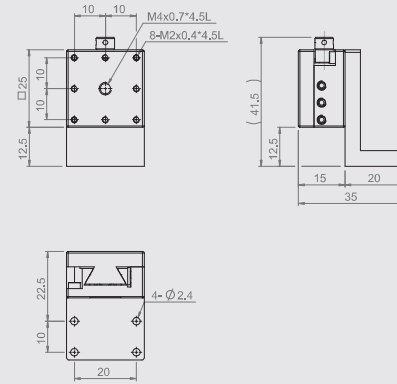

MC4E-40

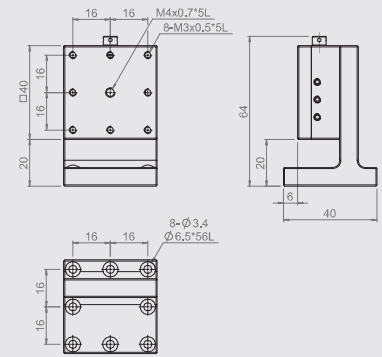

MC4E-60

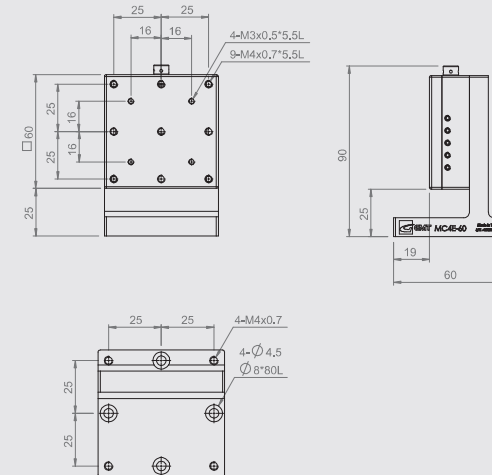

MC6E-25

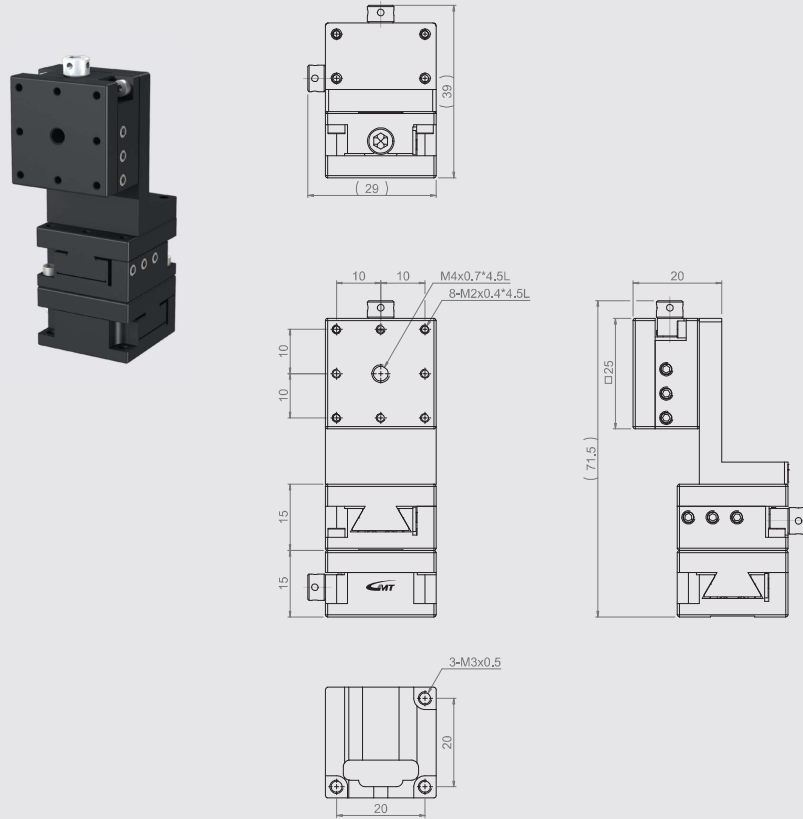

Specification

Unit : mm

Model No.	Table Size	Axis	Travel Stroke	Movement Per Knob Cycle	Straightness (μm)	Allowable Loading (kgf)	Weight (kg)	Material	Surface Finish
MC6E-25	25*25	XY+Z axis	±3	0.5	30	1.9	0.22	Brass alloy	Black floresin finished

MC1G-525C(F)

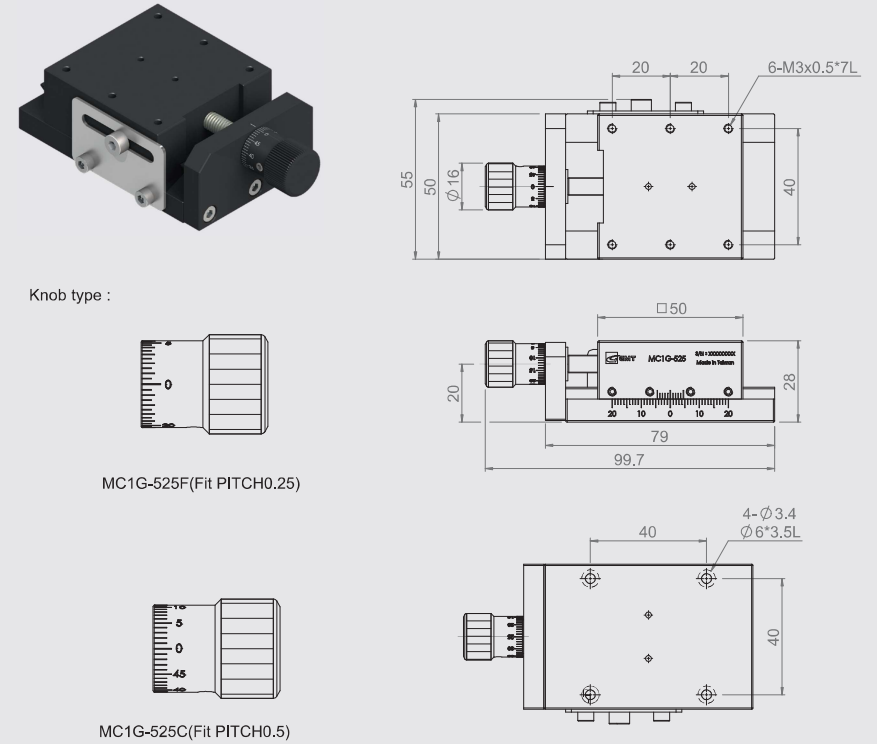

Knob type :

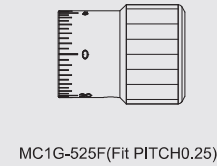

MC1G-525F(Fit PITCH0.25)

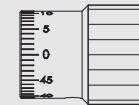

MC1G-525C(Fit PITCH0.5)

Specification

Unit : mm

Model No.	Table Size	Base Dimensions	Adjustment Structure			Straightness Accuracy	Parallel	Dynamic Parallel	Allowable Loading (kgf)	Weight (kg)	Material	Surface Finish
			Movement Per Knob Cycle	Knob Mini-Reading	Travel Stroke							
MC1G-525C	50*50	50*79	0.5	0.01/div.	±11	0.03	0.05	0.04	5	0.27	Aluminum alloy	Black anodized
MC1G-525F			0.25	0.005/div.								

MC1G-535C(F)

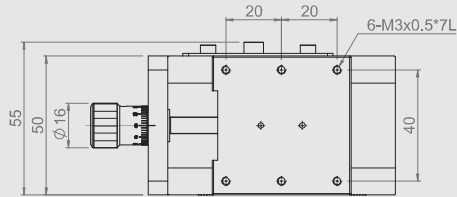

Knob type :

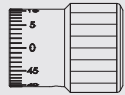

MC1G-535C(Fit PITCH0.5)



MC1G-535F(Fit PITCH0.25)

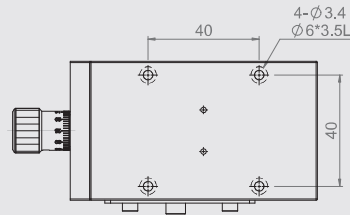
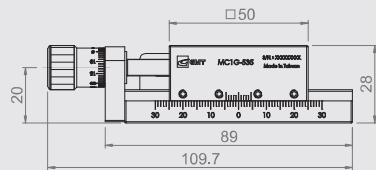

Specification

Unit : mm

Model No.	Table Size	Base Dimensions	Adjustment Structure			Straightness Accuracy	Parallel	Dynamic Parallel	Allowable Loading (kgf)	Weight (kg)	Material	Surface Finish
			Movement Per Knob Cycle	Knob Mini. Reading	Travel Stroke							
MC1G-535C	50*50	50*89	0.5	0.01/div.	±16	0.03	0.05	0.04	5	0.29	Aluminum alloy	Black anodized
MC1G-535F			0.25	0.005/div.								

MC7G-4050C(F)

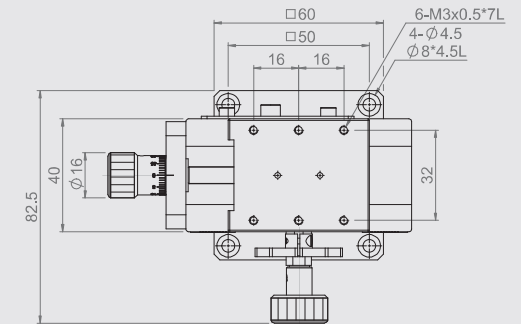
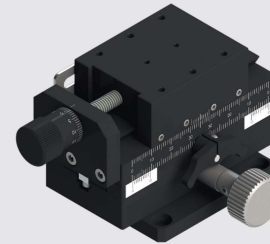

Knob type :

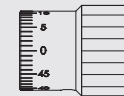

MC7G-4050C(Fit PITCH0.5)

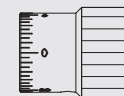

MC7G-4050F(Fit PITCH0.25)

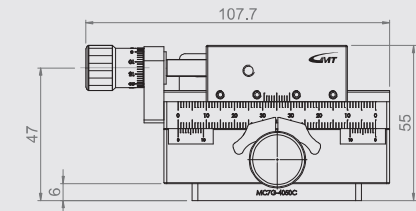

Specification

Unit : mm

Model No.	Table Size	Base Dimensions	Fine Tuning			Coarse Adjustment			Straightness Accuracy	Parallel	Dynamic Parallel	Allowable Loading (kgf)	Weight (kg)	Material	Surface Finish
			Movement Per Knob Cycle	Knob Mini. Reading	Travel Stroke	Movement Per Knob Cycle	Minimum Reading	Travel Stroke							
MC7G-4050C	40*50	40*80	0.5	0.01/div.	±17.5	≅ 18 mm	0.1mm / Vernier	±30	0.03	0.05	0.04	4	0.5	Aluminum alloy	Black anodized
MC7G-4050F			0.25	0.005/div.											

MC1B-35LG

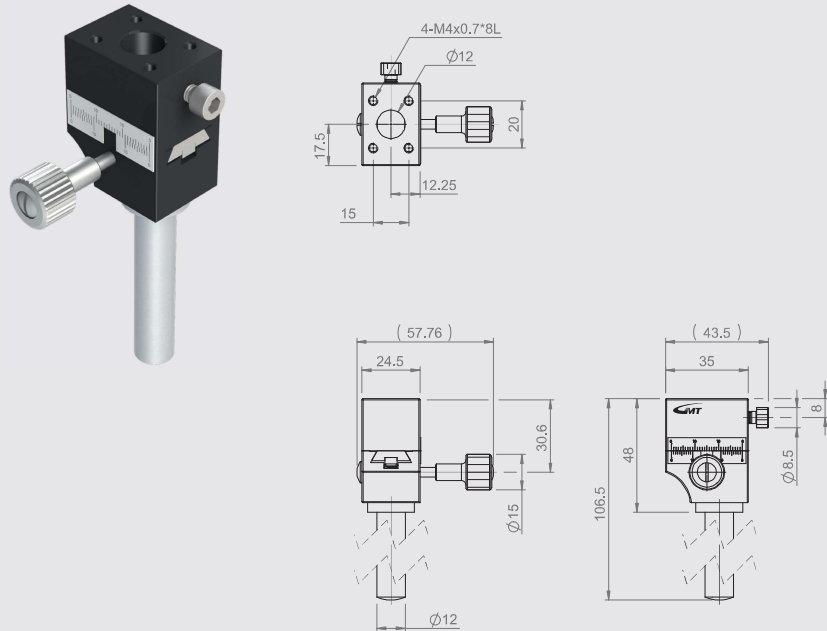

Specification

Unit : mm

Model No.	Table Size	Axis	Feed Position	Travel Stroke	Minimum Reading	Straightness Accuracy	Dynamic Straightness	Dynamic Parallel	Allowable Loading (kgf)	Weight (kg)	Material	Surface Finish
MC1B-35LG	24.5*35	X-axis	central	±10 mm	0.1mm / Vernier	0.03 mm	N / A	N / A	3	0.25	Aluminum alloy	Black anodized

MC6B-35LG

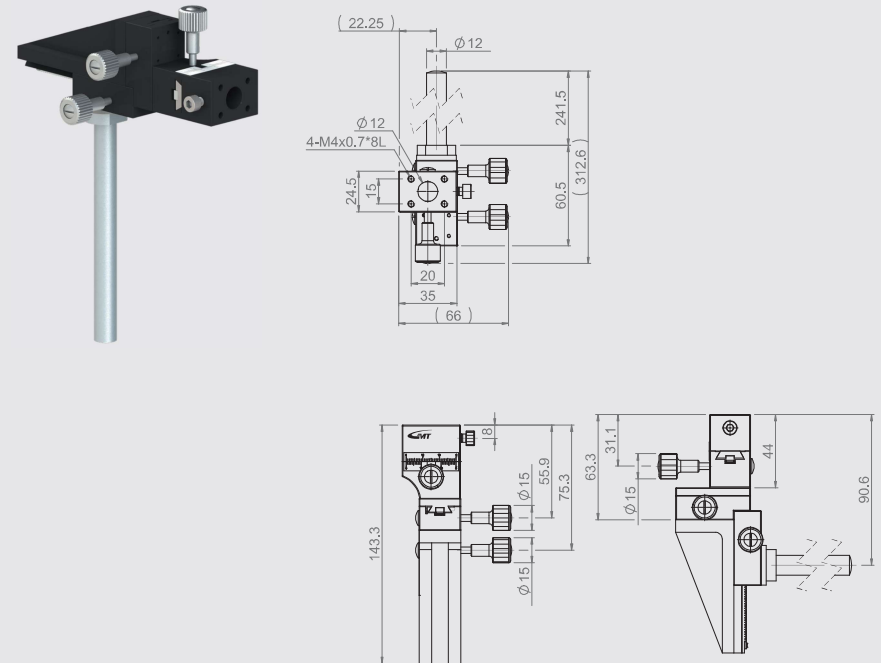

Specification

Unit : mm

Model No.	Axis / Travel Stroke			Movement Per Full Knob Rotation	Allowable Loading (kgf)	Weight (kg)	Material	Surface Finish
	X-axis	Y-axis	Z-axis					
MC6B-35LG				18	2	0.81	Aluminum alloy	Black anodized
	20	30	60					

MC1F-40

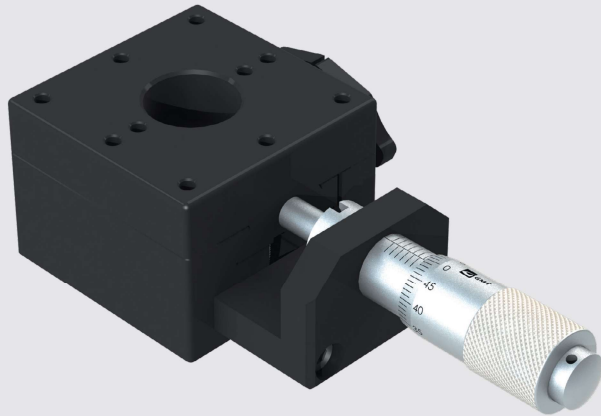

Specification

Unit : mm

Model No.	Table Size	Axis	Feed Position	Travel Stroke	Micrometer Minimum Reading	Straightness	Allowable Loading (kgf)	Weight (kg)	Material	Surface Finish
MC1F-40	40*40	X-axis	central	±10	10 μm	30 μm	3	0.17	Aluminum alloy	Black anodized

MC1F-40

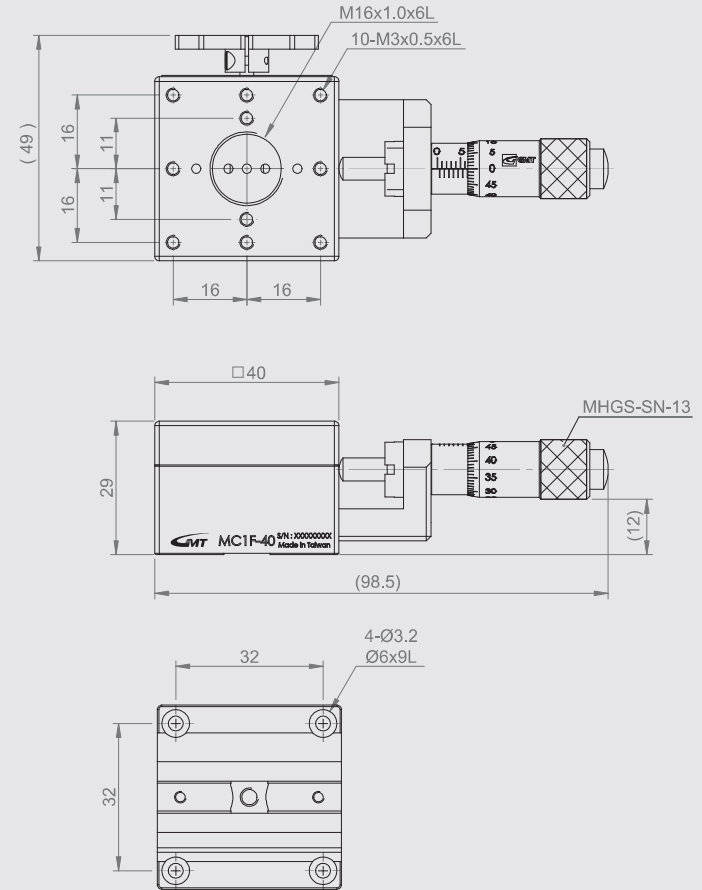

Model No. Description

MXG4-60CS

Transmission	Axis no.	Axis direction	Table size	Height of rotation center	Slide way	Feeding specification
M: Manual	X: Single axis Y: Dual axes	G: α & β axis	4 : 40 6 : 60	Refer to dimension tables	V: V groove rails C: Dovetail	E: Leadscrew S: Worm and worm gears M: Micrometer

MXG4-40CS

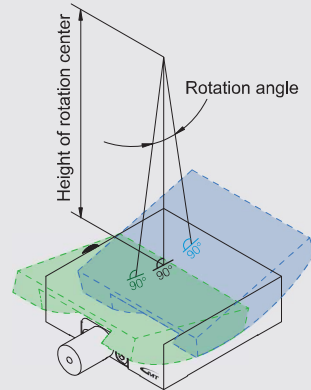

Specification

Unit : mm

Model No.	Table Size	Height of Rotation Center	Travel Stroke	Minimum Reading	Stroke Per Revolution	Allowable Loading (kgf)	Weight (kg)	Material	Surface Finish
MXG4-25CS	40*40	25	$\pm 20^\circ$	0.1°/ Vernier	$\approx 2.2^\circ$	3	0.18	Brass Alloy	Black fluororesin
MXG4-40CS		40	$\pm 15^\circ$		$\approx 1.89^\circ$				
MXG4-60CS		60	$\pm 10^\circ$		$\approx 1.33^\circ$				
MXG6-35CS	60*60	35	$\pm 25^\circ$		$\approx 2.0^\circ$	6	0.55		
MXG6-60CS		60	$\pm 20^\circ$		$\approx 1.3^\circ$				
MXG6-80CS		80	$\pm 15^\circ$		$\approx 1.0^\circ$				

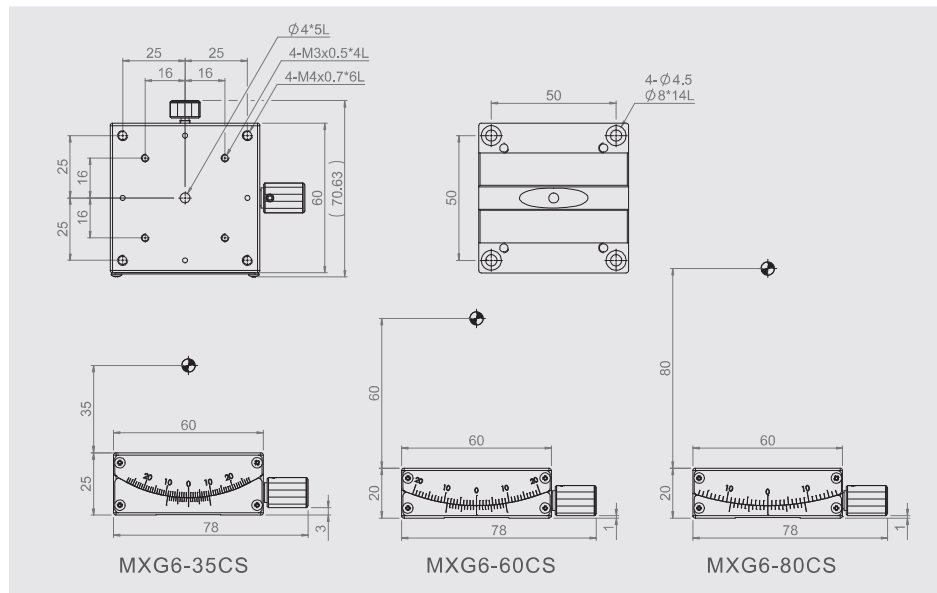
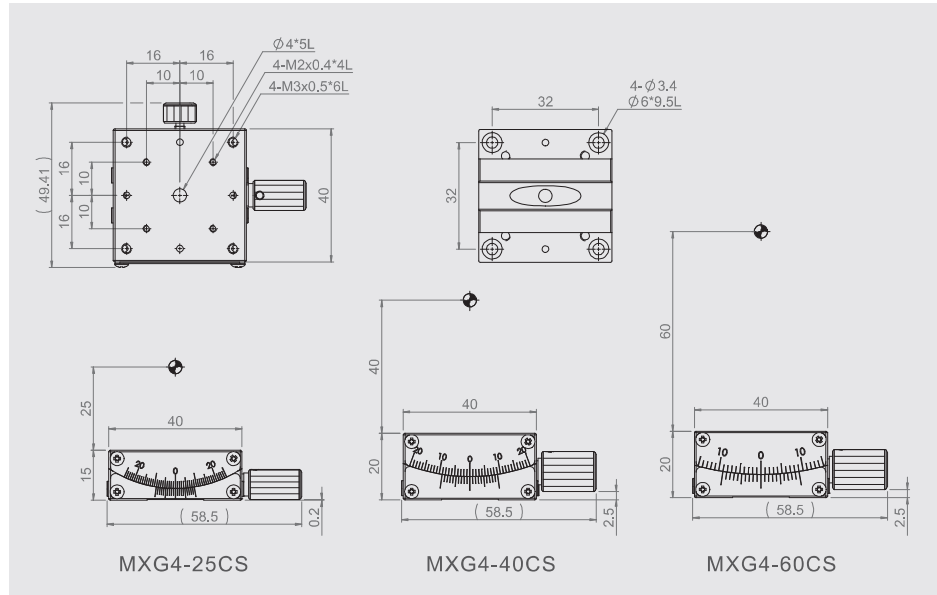

MYG4-40CS

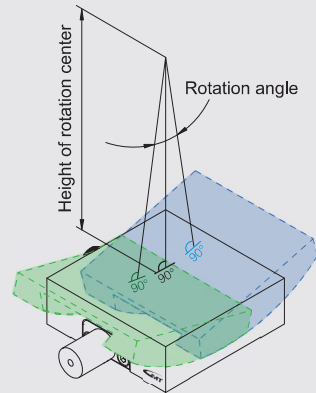

Specification

Unit : mm

Model No.	Table Size	Height of Rotation Center	Travel Stroke	Minimum Reading	Stroke Per Revolution	Allowable Loading (kgf)	Weight (kg)	Material	Surface Finish
MYG4-25CS	40*40	25	Upper axis ± 20° Lower axis ± 15°	0,1°/ Vernier	Upper axis ≙ 2.2° Lower axis ≙ 1.89°	2.8	0.42	Brass Alloy	Black fluororesin
MYG4-40CS		40	Upper axis ± 15° Lower axis ± 10°		Upper axis ≙ 1.89° Lower axis ≙ 1.33°	2.7	0.48		
MYG6-35CS	60*60	35	Upper axis ± 25° Lower axis ± 20°		Upper axis ≙ 2.0° Lower axis ≙ 1.3°	5.3	1.24		
MYG6-60CS		60	Upper axis ± 20° Lower axis ± 15°		Upper axis ≙ 1.3° Lower axis ≙ 1.0°	5.4	1.10		

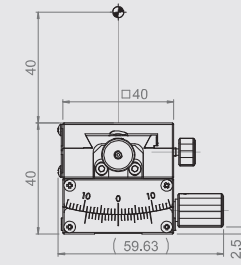
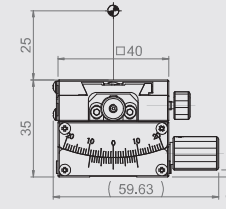
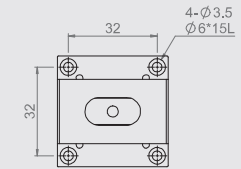
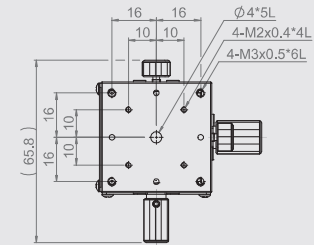

MYG4-25CS

MYG4-40CS

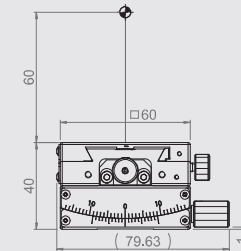
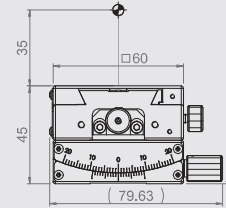
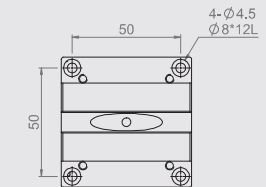
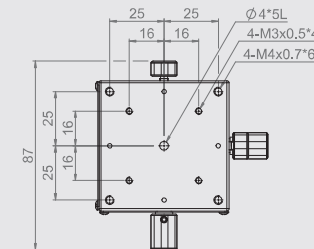

MYG6-35CS

MYG4-60CS

MXG5-□CS [α -axis]

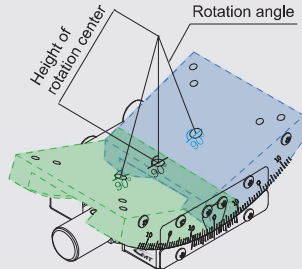

MYG5-□CS [$\alpha\beta$ -axis]

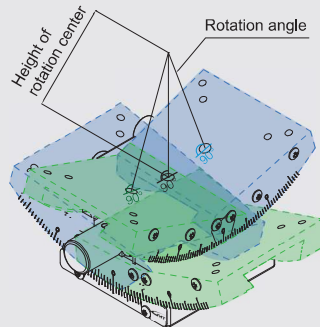

Specification

Unit : mm

Model No.	Table Size	Axis	Height of Rotation Center	Travel Stroke	Minimum Reading	Stroke Per Revolution	Allowable Loading (kgf)	Weight (kg)	Material	Surface Finish
MXG5-50CS	50*50	α	50	$\pm 10^\circ$	0.1°/ Vernier	$\approx 1.55^\circ$	3	0.36	Brass Alloy	Black fluororesin
MXG5-68CS			68	$\pm 10^\circ$		$\approx 1.2^\circ$				
MXG5-86CS			86	$\pm 8^\circ$		$\approx 0.97^\circ$				
MYG5-50CS	50*50	$\alpha\beta$	50	Upper axis $\pm 10^\circ$ Lower axis $\pm 10^\circ$	0.1°/ Vernier	Upper axis $\approx 1.55^\circ$ Lower axis $\approx 1.2^\circ$	0.71	Brass Alloy	Black fluororesin	
MYG5-68CS			68	Upper axis $\pm 10^\circ$ Lower axis $\pm 8^\circ$		Upper axis $\approx 1.2^\circ$ Lower axis $\approx 0.97^\circ$				

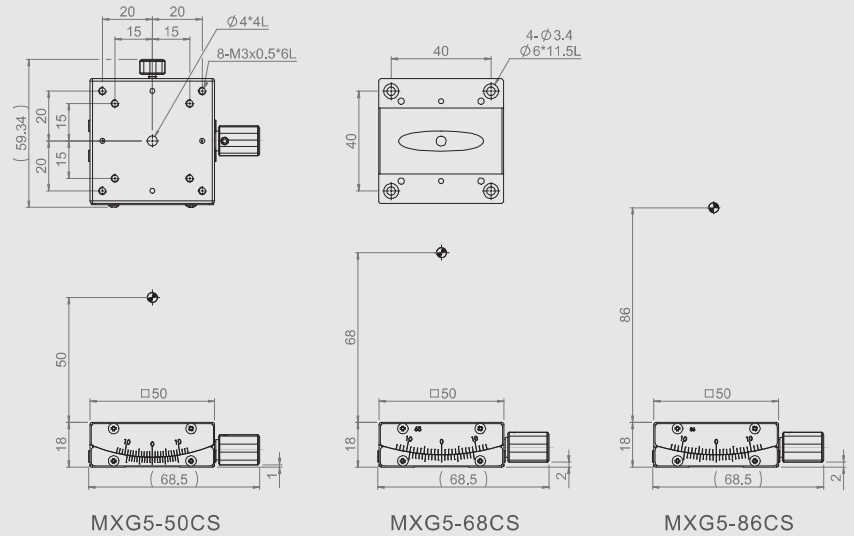

MXG5-50CS

MXG5-68CS

MXG5-86CS

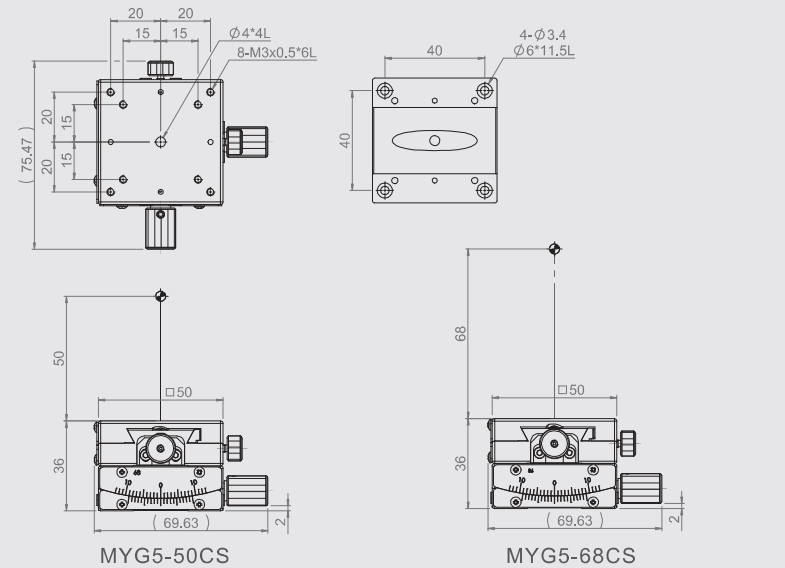

MYG5-50CS

MYG5-68CS

MXG9-118CS

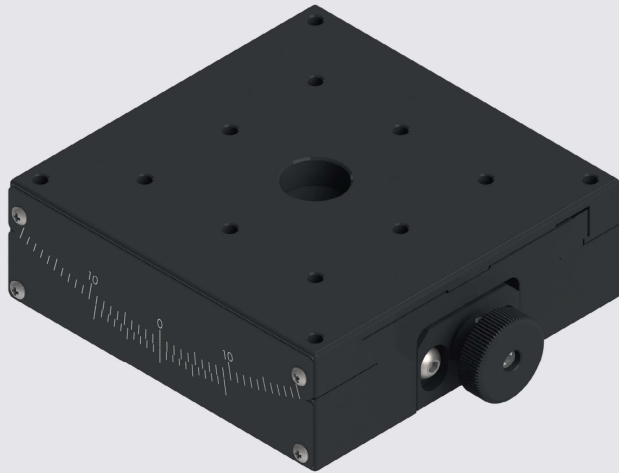

Specification

Unit : mm

Model No.	Table Size	Axis	Feed Position	Height of Rotation Center	Travel Stroke	Minimum Reading	Micrometer Minimum Reading	Allowable Loading (kgf)	Weight (kg)	Material	Surface Finish
MXG9-118CS	90*90	α	Central	100	$\pm 12^\circ$	1° / Vernier	$\div 92''$	7.5	0.33	Brass alloy	Black fluororesin

MXG9-118CS

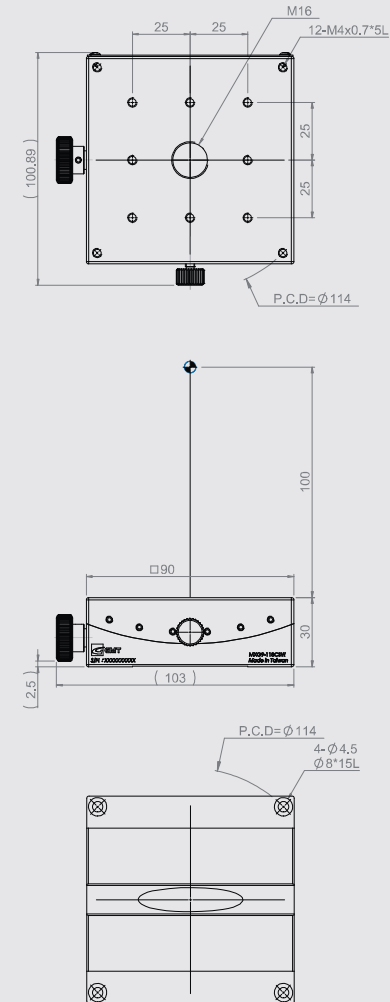

MXG3-30CE



MYG3-30CE



Specification

Unit : mm

Model No.	Table Size	Axis	Height of Rotation Center	Travel Stroke	Minimum Reading	Stroke Per Revolution	Allowable Loading (kgf)	Weight (kg)	Material	Surface Finish
MXG3-30CE	30*30	α	30	$\pm 8^\circ$	1"/ Vernier	$\approx 44'39''$	1.5	0.1	Brass Alloy	Black fluororesin
MXG3-44CE			44	$\pm 6^\circ$		$\approx 33'23''$				
MXG3-57CE			57	$\pm 5^\circ$		$\approx 26'39''$				
MYG3-30CE	30*30	$\alpha\beta$	30	Upper axis $\pm 8^\circ$ Lower axis $\pm 6^\circ$		Upper axis $\approx 44'39''$ Lower axis $\approx 33'23''$		0.2		
MYG3-44CE			44	Upper axis $\pm 6^\circ$ Lower axis $\pm 5^\circ$		Upper axis $\approx 33'23''$ Lower axis $\approx 26'39''$				

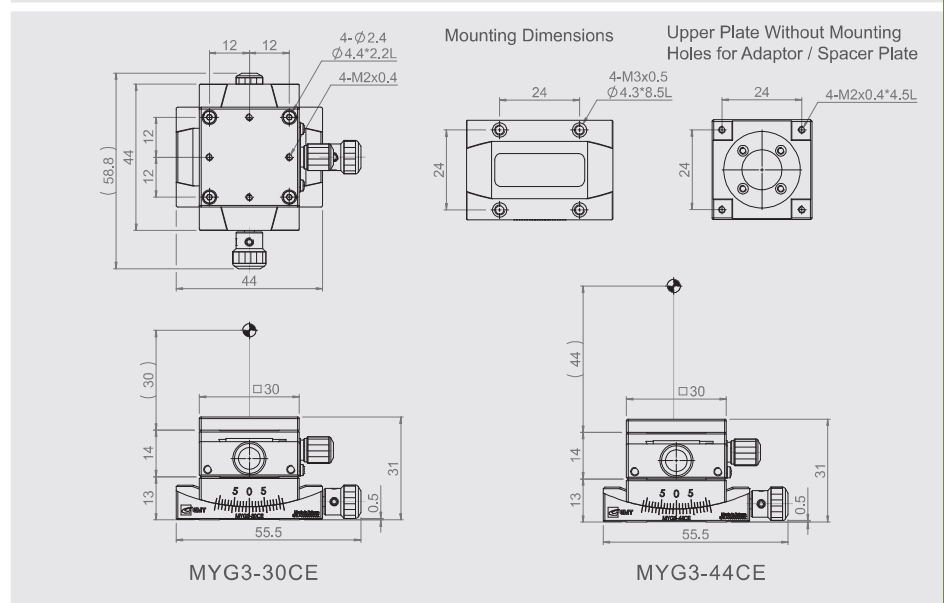
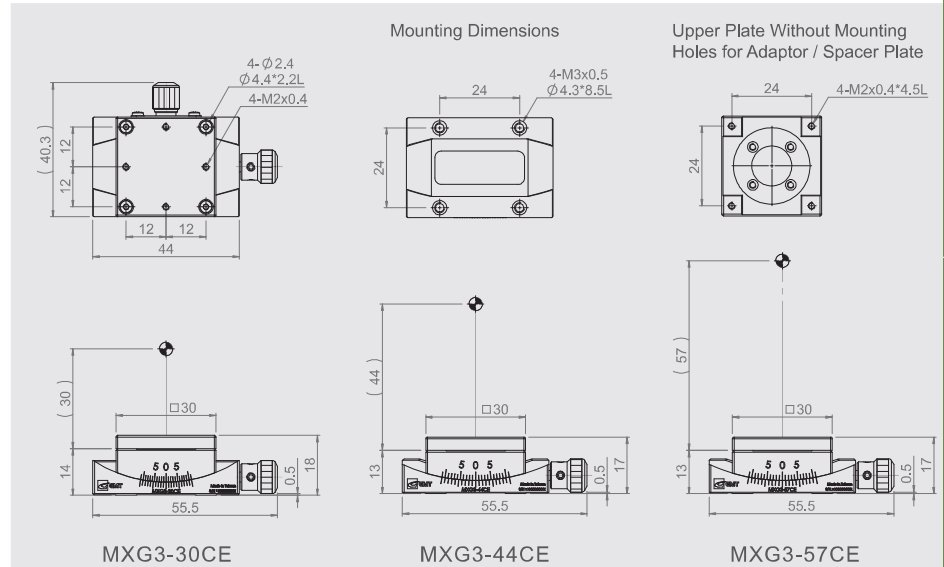

MXG4-50CE



MYG4-50CE

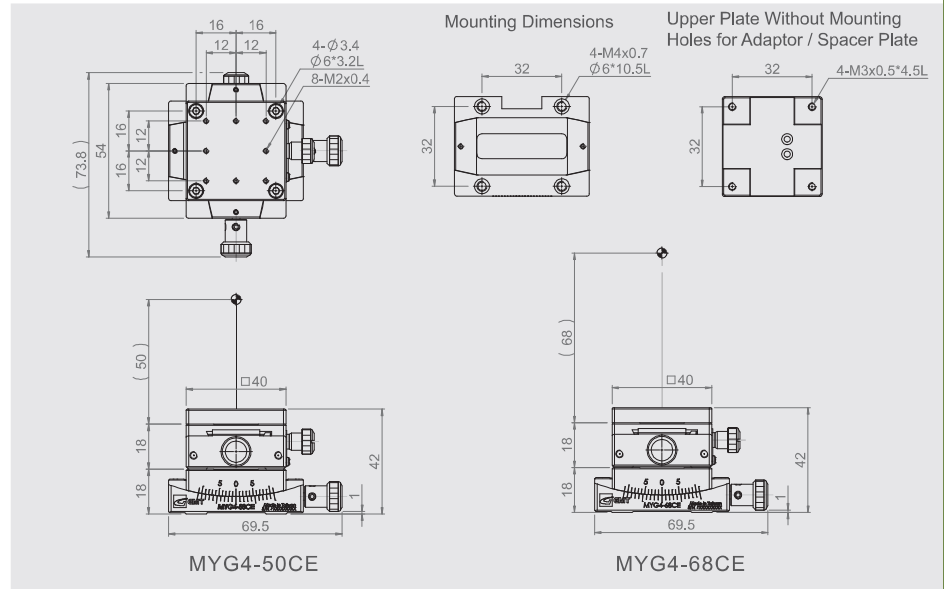
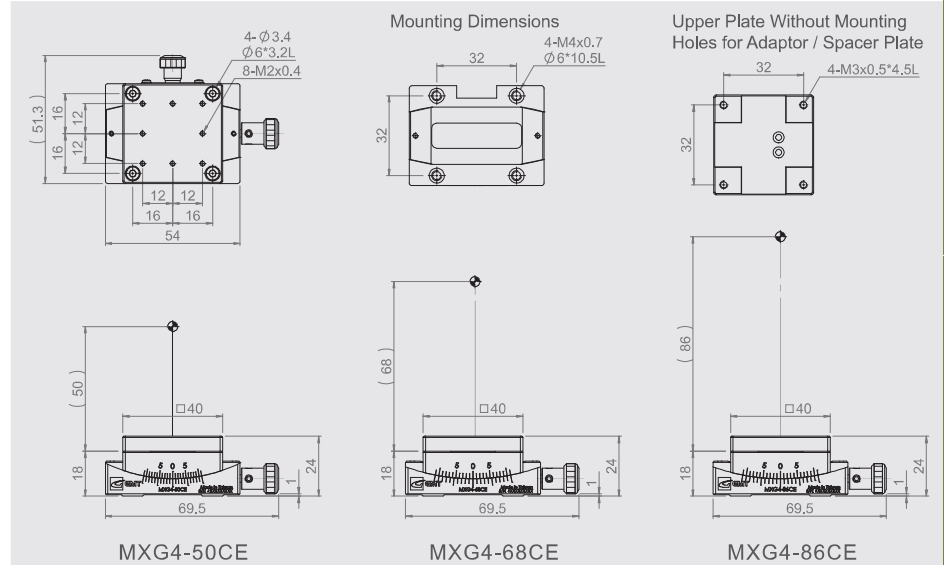

Specification

Unit : mm

Model No.	Table Size	Axis	Height of Rotation Center	Travel Stroke	Minimum Reading	Stroke Per Revolution	Allowable Loading (kgf)	Weight (kg)	Material	Surface Finish
MXG4-50CE	40*40	α	50	$\pm 8^\circ$	1°/ Vernier	$\approx 28'11''$	3	0.3	Brass Alloy	Black fluororesin
MXG4-68CE			68	$\pm 6^\circ$		$\approx 21'45''$				
MXG4-86CE			86	$\pm 5^\circ$		$\approx 17'43''$				
MYG4-50CE		$\alpha\beta$	50	Upper axis $\pm 8^\circ$ Lower axis $\pm 6^\circ$		Upper axis $\approx 28'11''$ Lower axis $\approx 21'45''$		0.6		
MYG4-68CE			68	Upper axis $\pm 6^\circ$ Lower axis $\pm 5^\circ$		Upper axis $\approx 21'45''$ Lower axis $\approx 17'43''$				

MXG6-70CE



MYG6-70CE

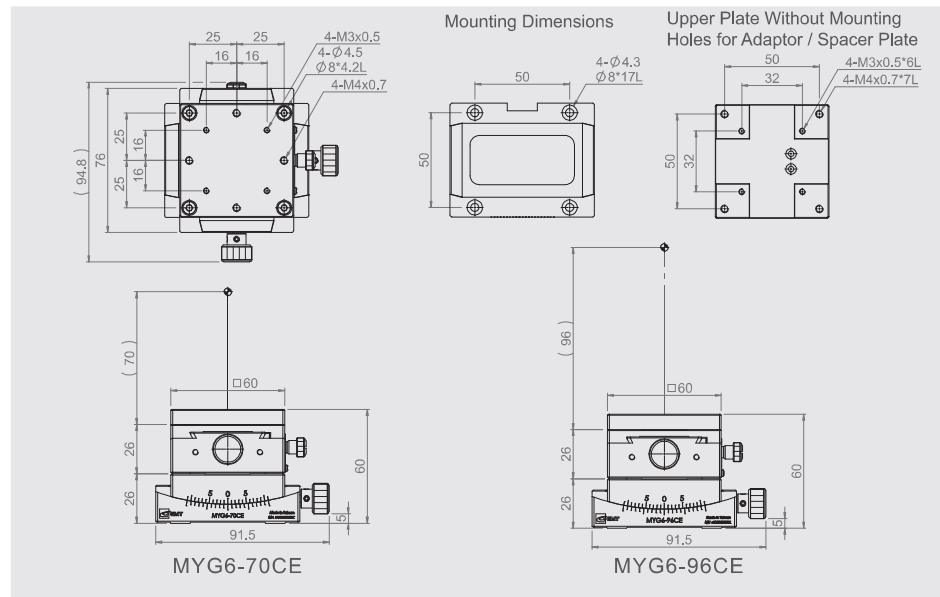
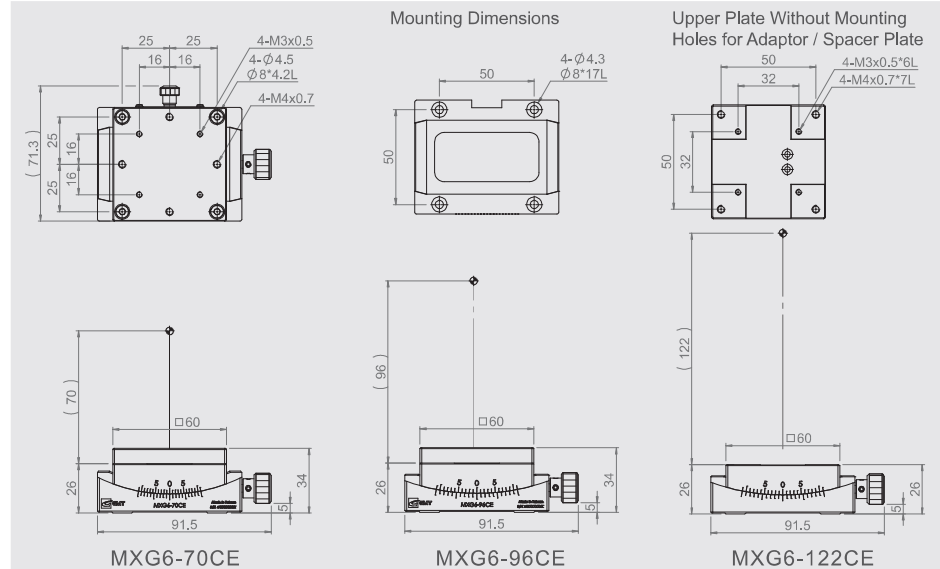
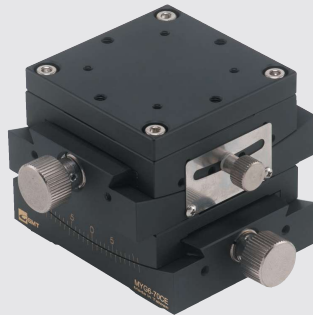

Specification

Unit : mm

Model No.	Table Size	Axis	Height of Rotation Center	Travel Stroke	Minimum Reading	Stroke Per Revolution	Allowable Loading (kgf)	Weight (kg)	Material	Surface Finish
MXG6-70CE	60*60	α	70	$\pm 8^\circ$	1"/ Vernier	= 19'59"	5	0.7	Brass Alloy	Black fluororesin
MXG6-96CE			96	$\pm 6^\circ$		= 15'21"				
MXG6-122CE			122	$\pm 5^\circ$		= 12'27"				
MYG6-70CE	60*60	$\alpha\beta$	70	Upper axis $\pm 8^\circ$ Lower axis $\pm 6^\circ$	1"/ Vernier	Upper axis = 19'59" Lower axis = 15'21"	5	1.4	Brass Alloy	Black fluororesin
MYG6-96CE			96	Upper axis $\pm 6^\circ$ Lower axis $\pm 5^\circ$		Upper axis = 15'21" Lower axis = 12'27"				

MXG4-□□VM



MXG5-50VM

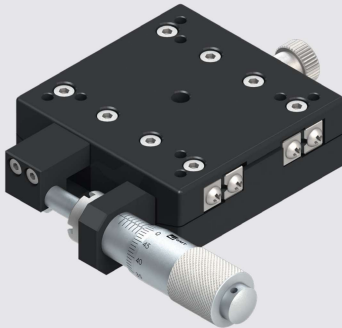

Specification

Unit : mm

Model No.	Table Size	Axis	Feed Position	Height of Rotation Center	Travel Stroke	Minimum Reading	Micrometer Minimum Reading	Allowable Loading (kgf)	Weight (kg)	Material	Surface Finish
MXG4-40VM	40*40	α	Side	40	$\pm 7^*$	0.1 [*]	$\div 40''$	3	0.15	Aluminum alloy	Black anodized
MXG4-60VM	40*40			60	$\pm 4^*$		$\div 29''$		0.15		
MXG4-80VM	40*40			80	$\pm 4^*$		$\div 22''$		0.15		
MXG5-50VM	50*50			50	$\pm 3^*$		$\div 53''$		0.2		

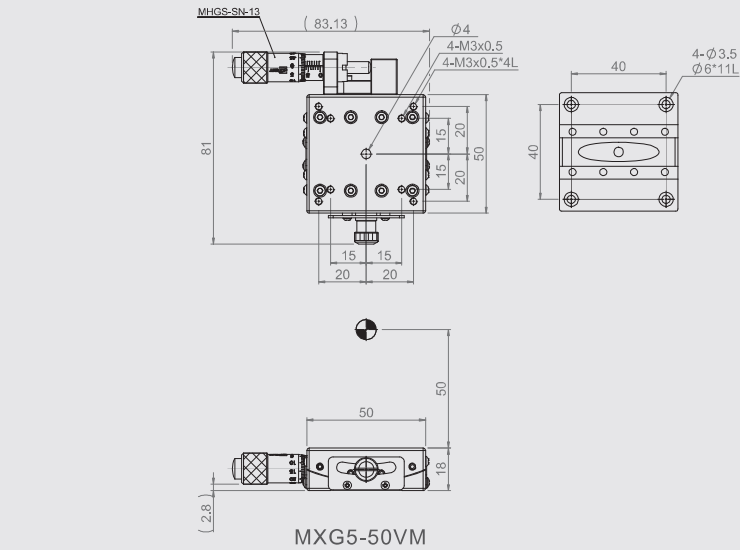
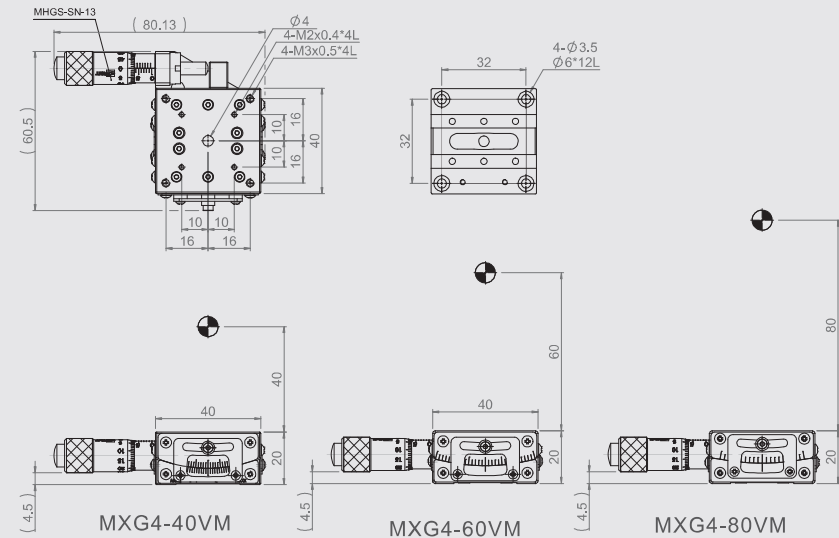

MXG6-□ VM

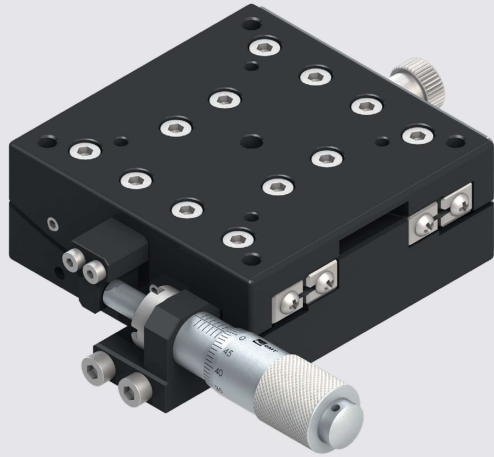

Specification

Unit : mm

Model No.	Table Size	Axis	Feed Position	Height of Rotation Center	Travel Stroke	Minimum Reading	Micrometer Minimum Reading	Allowable Loading (kgf)	Weight (kg)	Material	Surface Finish
MXG6-50VM	60*60	α	Side	50	$\pm 4'$	0.1"	$\div 32''$	4.5	0.33	Aluminum alloy	Black anodized
MXG6-75VM	60*60			75	$\pm 3'$		$\div 23''$				
MXG6-100VM	60*60			100	$\pm 3'$		$\div 18''$				

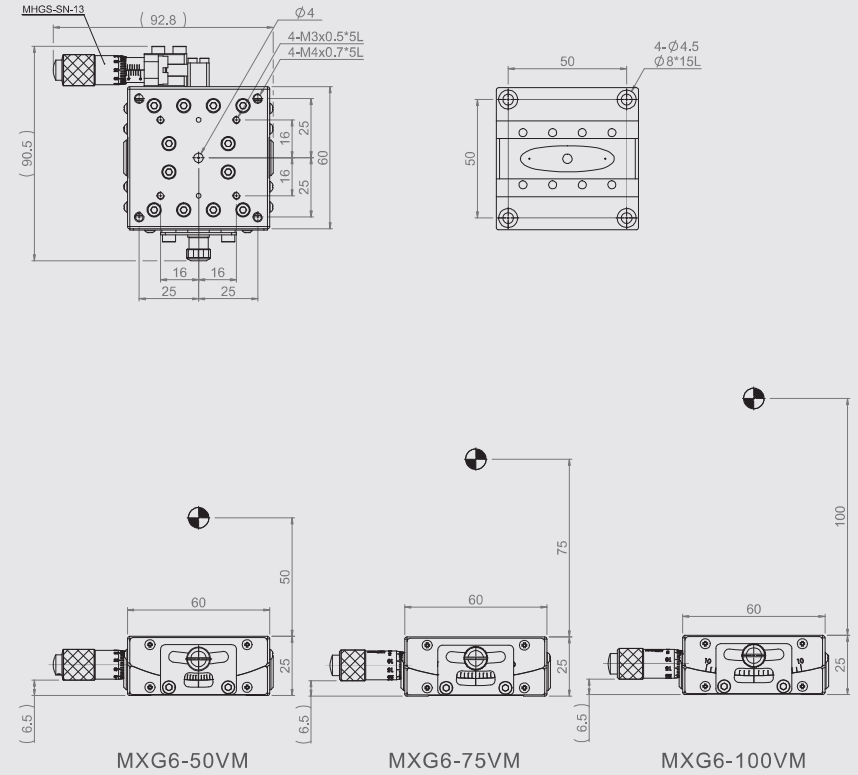

MCV100-AS

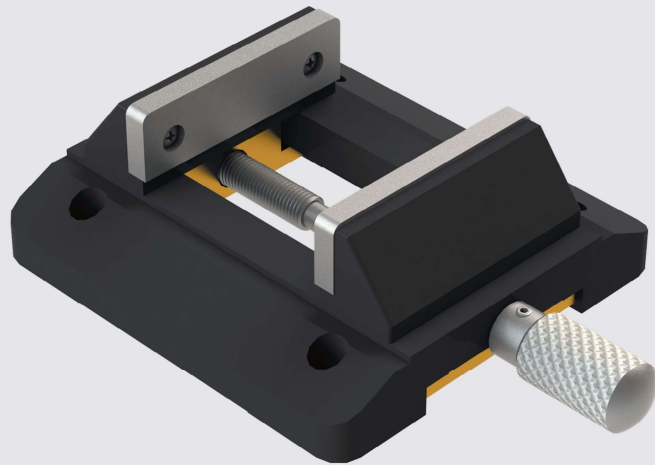

Specification

Unit : mm

Model No.	Table Size	Feed Position	Clamping Dimension	Allowable Loading (kgf)	Weight (kg)	Material	Surface Finish
MCV100-AS	100*94	Side	0~49	20	0.55	Aluminum alloy	Black anodized

MCV100-AS

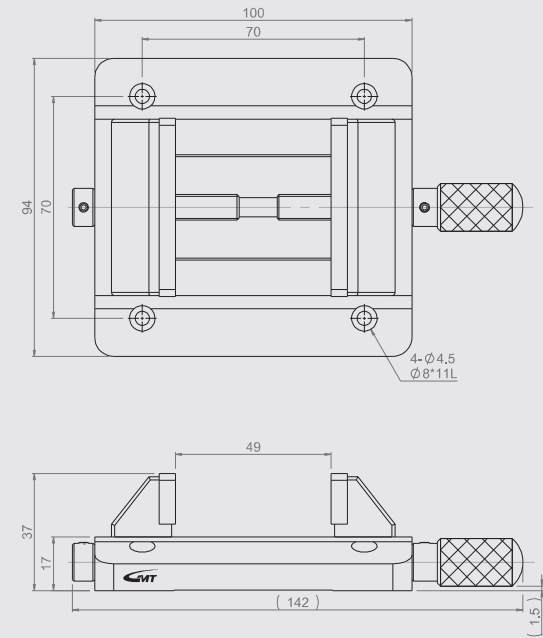

M3E-2000S-L

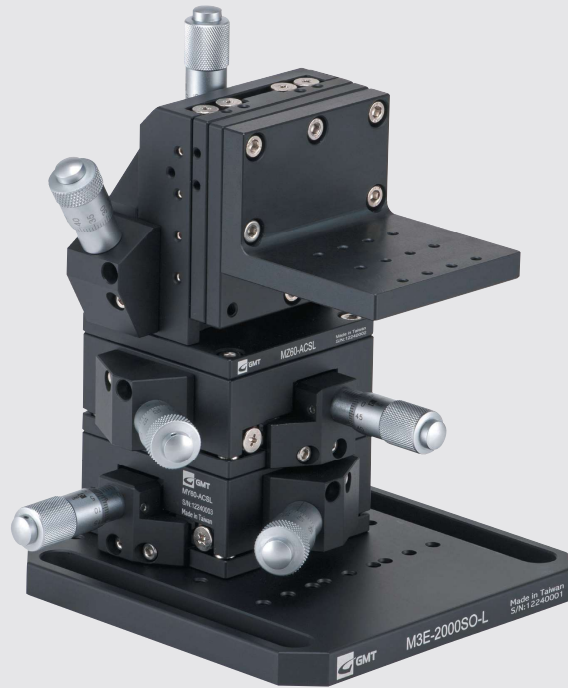

Specification

Unit : mm

Axis	Specification	Travel Stroke		Resolution	
		Cursory Tuning (mm)	Fine Tuning (mm)	Cursory Tuning (μm)	Fine Tuning (μm)
X		±6.5	±0.3	10	0.5
Y		±6.5	±0.3	10	0.5
Z		±6.5	±0.3	10	0.5

M3E-2000S-L models consist of the XYZ manual positioning stage and a L-bracket in order to perform tilt movement.

Remark : There are available options for XYZ module with ordering code : MXYZ60-ACSL.

The images are used as reference. For the actual designs, please refer to the 2D drawing (download).

M3E-2000S-L

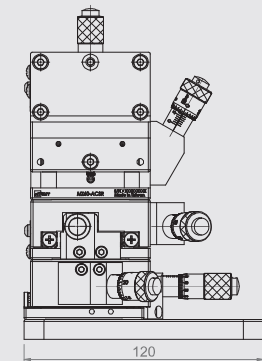
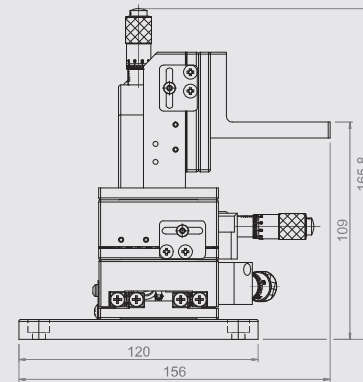
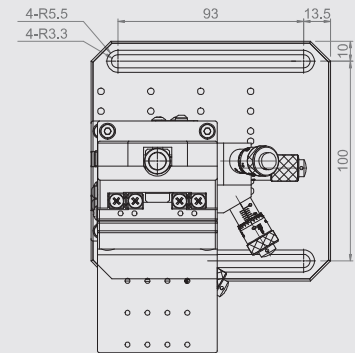

M3E-2000S-R

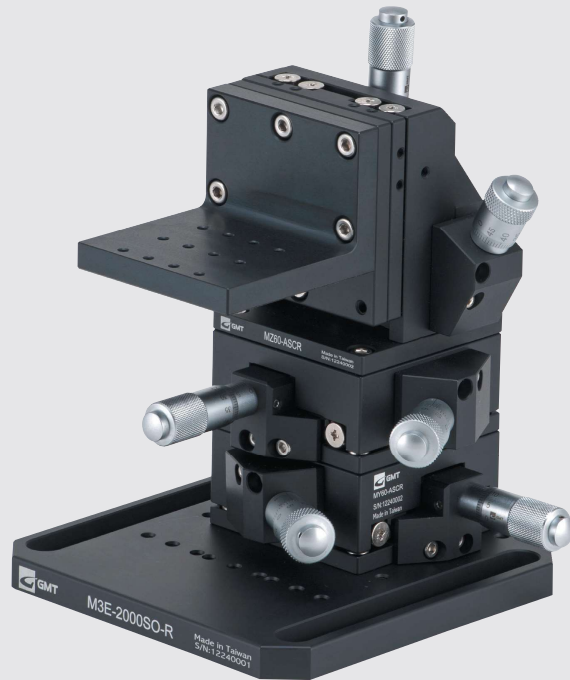

Specification

Unit : mm

Axis	Travel Stroke		Resolution	
	Cursory Tuning (mm)	Fine Tuning (mm)	Cursory Tuning (μm)	Fine Tuning (μm)
X	±6.5	±0.3	10	0.5
Y	±6.5	±0.3	10	0.5
Z	±6.5	±0.3	10	0.5

M3E-2000S-R models consist of the XYZ manual positioning stage and a L-bracket in order to perform tilt movement.

Remark : There are available options for XYZ module with ordering code : MXYZ60-ACSR.

The images are used as reference. For the actual designs, please refer to the 2D drawing (download).

M3E-2000S-R

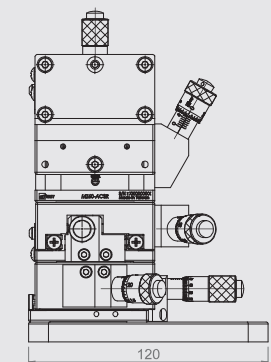
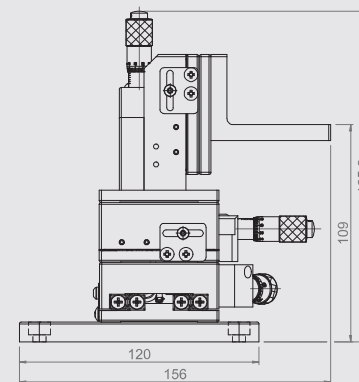
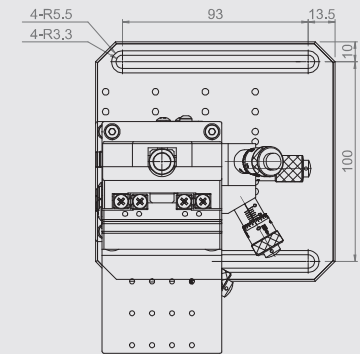

M5E-2000B-L

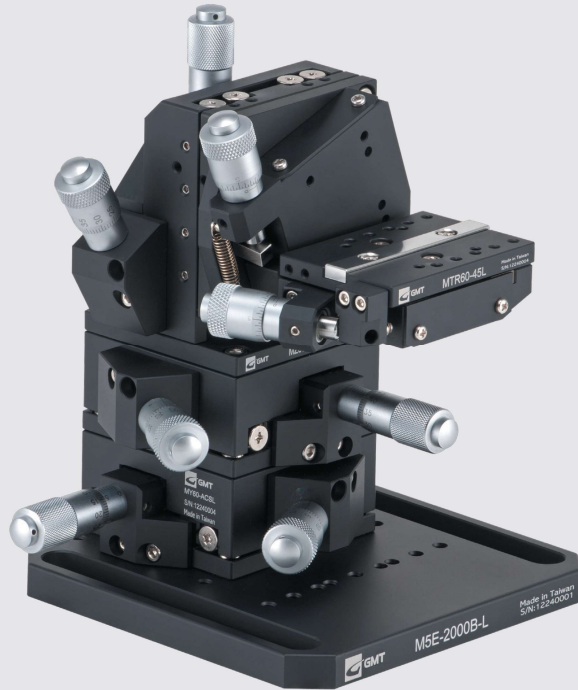

Specification

Unit : mm

Axis	Specification	Travel Stroke		Resolution	
		Cursory Tuning (mm)	Fine Tuning (mm)	Cursory Tuning (μm)	Fine Tuning (μm)
X		± 6.5	± 0.3	10	0.5
Y		± 6.5	± 0.3	10	0.5
Z		± 6.5	± 0.3	10	0.5
θ_x		$\pm 3^\circ$		≈ 29.3 "/div.	
θ_y		$\pm 3^\circ$		≈ 27.8 "/div.	

M5E-2000B-L models consist of the XYZ manual positioning stage and a tilt stage (θ_x , θ_y). It is a 5-axis high resolution positioning stage to be designed to perform the single-fiber positioning.
(Without translation) : The height of the rotational center is approximately 130mm, and could be heightened by adding the adaptor plates.

Remark : For separate order :
XYZ module - MXYZ60-ACSL
Tilt module - MTR60-45R

The images are used as reference. For the actual designs, please refer to the 2D drawing (download).a

M5E-2000B-L

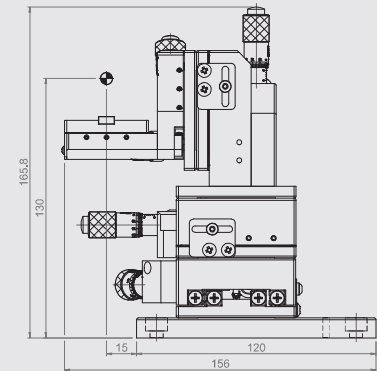
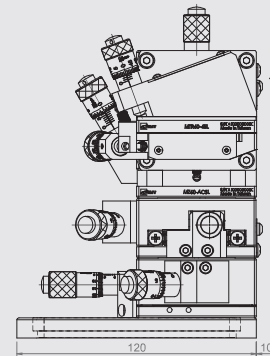
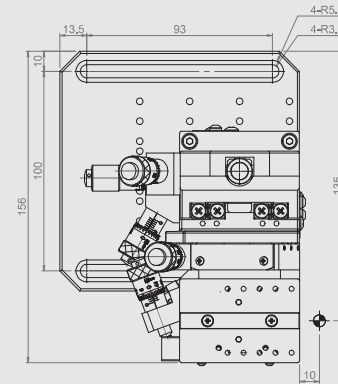

M5E-2000B-R

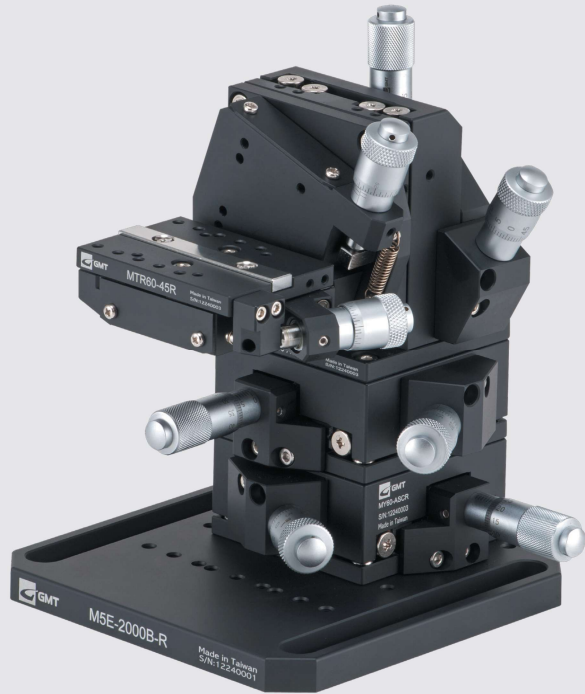

Specification

Unit : mm

Specification	Travel Stroke		Resolution	
	Cursory Tuning (mm)	Fine Tuning (mm)	Cursory Tuning (μ m)	Fine Tuning (μ m)
X	± 6.5	± 0.3	10	0.5
Y	± 6.5	± 0.3	10	0.5
Z	± 6.5	± 0.3	10	0.5
θ_x	$\pm 3^\circ$		≈ 29.3 "/div.	
θ_y	$\pm 3^\circ$		≈ 27.8 "/div.	

M5E-2000B-R models consist of the XYZ manual positioning stage and a tilt stage (θ_x , θ_y). It is a 5-axis high resolution positioning stage to be designed to perform the single-fiber positioning.

The height of the rotational center is approximately 130mm, and could be heightened by adding the adaptor plates.

For more information, please visit our website (www.gmlinear.com) or contact to local agents.

For separate order :

XYZ stage module : MXYZ 60-ACSR

Tilt stage module : MTR60-45R

The images are used as reference. For the actual designs, please refer to the 2D drawing. (download).

M5E-2000B-R

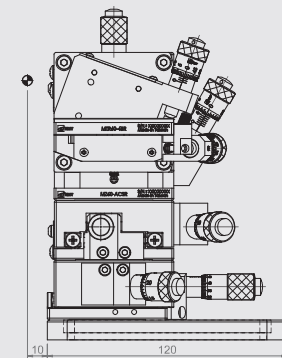
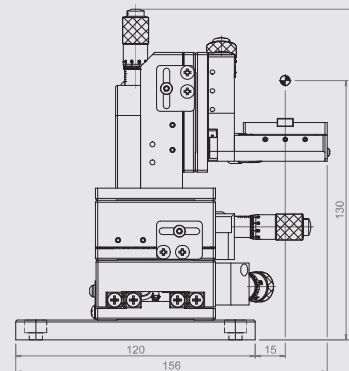
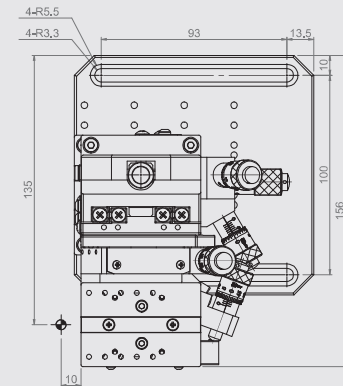

M6E-2200B-L

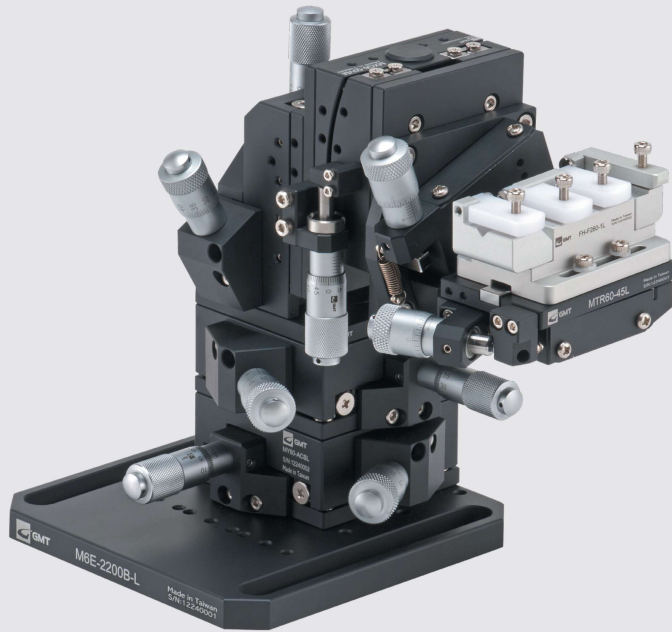

Coarse Tuning Fine Tuning Coarse Tuning Fine Tuning

Specification

Unit : mm

Axis	Specification	Travel Stroke		Resolution	
		Cursory Tuning (mm)	Fine Tuning (mm)	Cursory Tuning (μ m)	Fine Tuning (μ m)
X		± 6.5	± 0.3	10	0.5
Y		± 6.5	± 0.3	10	0.5
Z		± 6.5	± 0.3	10	0.5
θ_x		$\pm 3^\circ$		$\approx 29.3^\circ/\text{div.}$	
θ_y		$\pm 3^\circ$		$\approx 27.8^\circ/\text{div.}$	
θ_z		$\pm 4^\circ$		$\approx 33^\circ/\text{div.}$	

M6E-2200B-L models consist of the XYZ manual positioning stage and a tilt stage (θ_x , θ_y). It is a 5-axis high resolution positioning stage to be designed to perform the single-fiber positioning or as the application for industry of optical waveguide. The height of the rotational center is approximately 130mm, and could be heightened by adding the adaptor plates. For more information, please visit our website (www.gmtlinear.com) or contact to local agents.

For separate order :

XYZ stage module : MXYZ60-ACSL

Tilt stage module : MTR60-45R

a-axis stage : MXG6-50VMR

The images are used as reference. For the actual designs, please refer to the 2D drawing (download).

M6E-2200B-L

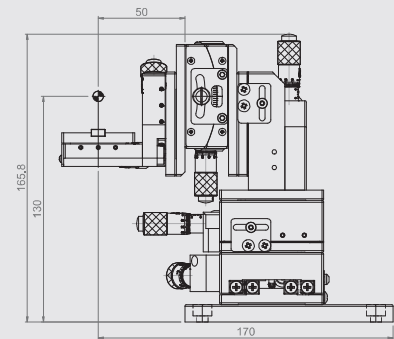
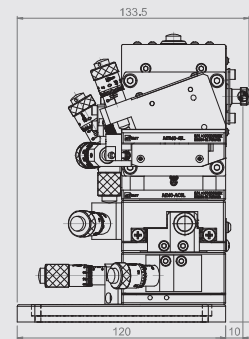
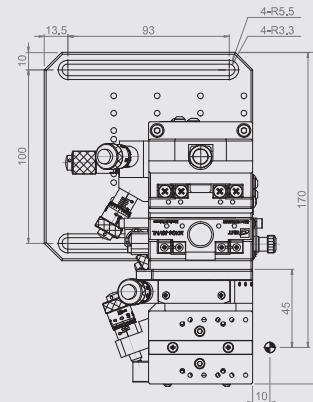

M6E-2200B-R

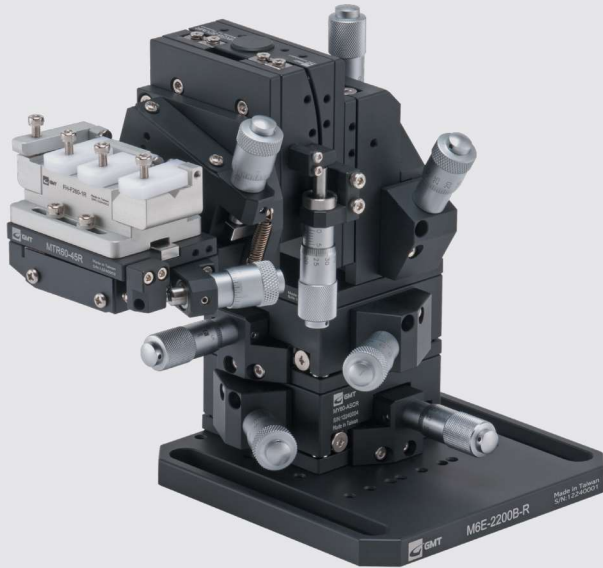

Specification

Unit : mm

Specification	Travel Stroke		Resolution	
	Cursory Tuning (mm)	Fine Tuning (mm)	Cursory Tuning (μ m)	Fine Tuning (μ m)
X	± 6.5	± 0.3	10	0.5
Y	± 6.5	± 0.3	10	0.5
Z	± 6.5	± 0.3	10	0.5
θ_x	$\pm 3^\circ$		$\approx 29.3 \text{ }^\circ/\text{div.}$	
θ_y	$\pm 3^\circ$		$\approx 27.8 \text{ }^\circ/\text{div.}$	
θ_z	$\pm 4^\circ$		$\approx 33 \text{ }^\circ/\text{div.}$	

M6E-2200B-R models consist of the XYZ manual positioning stage and a tilt stage (θ_x , θ_y). It is a 6-axis high resolution positioning stage in order to perform the single-fiber positioning or as the application for industry of optical waveguide.
 (Without translation) : The height of the rotational center is approximately 130mm, and could be heightened by adding the adaptor plates.
 For more information, please visit our website (www.gmtlinear.com) or contact to local agents.

For separate order :
 XYZ stage module : MXYZ60-ACSL
 Tilt stage module : MTR60-45R
 a-axis stage : MXG6-50VMR

The images are used as reference. For the actual designs, please refer to the 2D drawing (download).

M6E-2200B-R

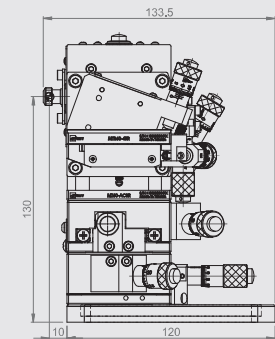
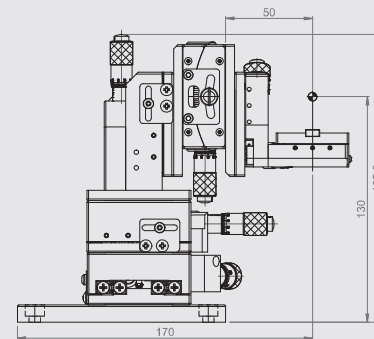
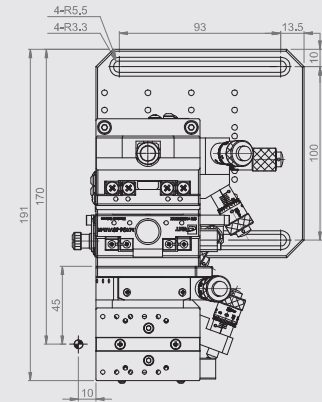

M5F-460A561-L



Specification

Unit : mm

Specification	Travel Stroke [Inch.(mm)]	Allowable Loading (N)	Material
X	0.5(12.7)	67	Aluminum alloy
Y	0.5(12.7)		
Z	0.5(12.7)		
θ_x	$\pm 5^\circ$	Stainless Steel	
θ_y	$\pm 5^\circ$		

Thread Hole	Size [Inch.(mm)]		
	A	B	C
1/4-20	0.5(12.5)	1(25.4)	

The module combines : MTS-561L, MXYZ-460AL, M5F-460A561-BKT.
M5F-460A561-L models consist of the XYZ manual positioning stage and a tilt stage (θ_x , θ_y). It is a 6-axis high resolution positioning stage in order to perform the single-fiber positioning.
For more information, please visit our website (www.gmtlinear.com) or contact to local agents.
For separate order :
XYZ stage module : MXYZ460-AL
Tilt stage module : MTS-561-L

M5F-460A561-L

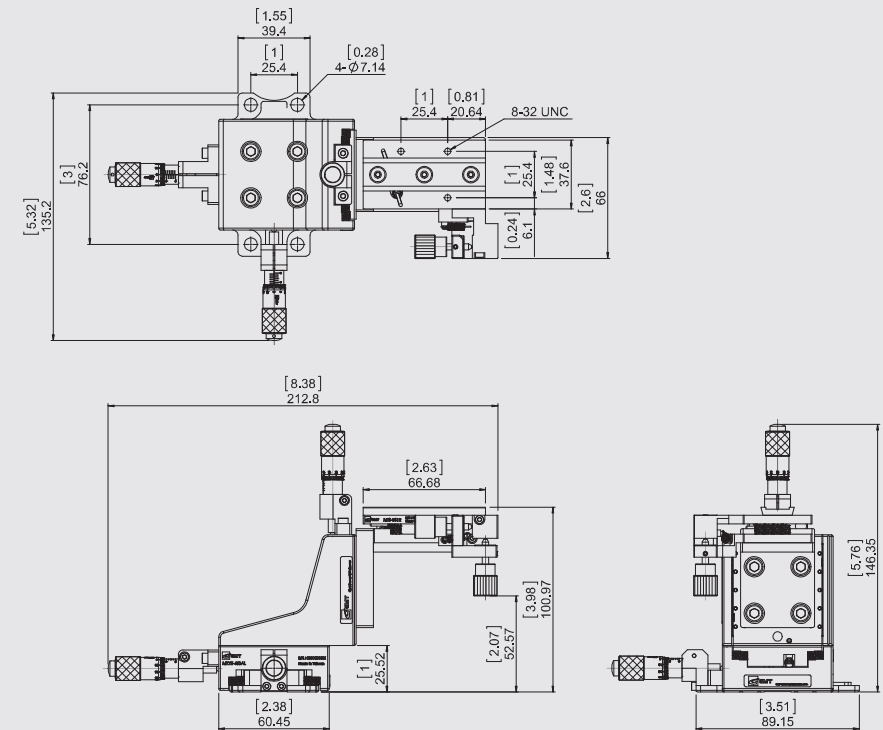

M5F-460A561-R



Specification

Unit : mm

Specification	Travel Stroke [Inch.(mm)]	Allowable Loading (N)	Material
X	0.5(12.7)	67	Aluminum alloy
Y	0.5(12.7)		
Z	0.5(12.7)		
θ_x	$\pm 5^\circ$	Stainless Steel	
θ_y	$\pm 5^\circ$		

Thread Hole	Size [Inch.(mm)]		
	A	B	C
1/4-20	0.5(12.5)	1(25.4)	

The module combines : MTS-561R, MXYZ-460AR, M5F-460A561-BKT.
M5F-460A561-R models consist of the XYZ manual positioning stage and a tilt stage (θ_x , θ_y). It is a 6-axis high resolution positioning stage in order to perform the single-fiber positioning.
For more information, please visit our website (www.gmtlinear.com) or contact to local agents.
For separate order :
XYZ stage module : MXYZ460-AR
Tilt stage module : MTS-561-R

M5F-460A561-R

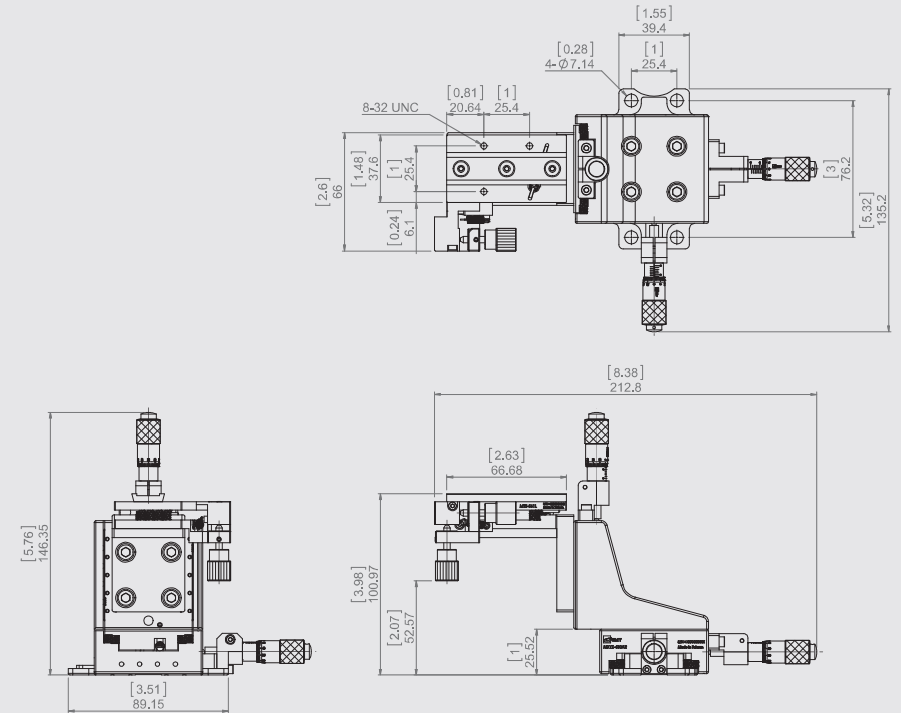

MTS-561-L



Specification

Unit : mm

Axis	Specification	Travel Stroke	Sensitivity	Allowable Loading (N)	Material
θ_x		$\pm 5^\circ$	Each circular motion equals 5arc-seconds	22	Stainless Steel
θ_y		$\pm 5^\circ$			

The body of MTS-561-L made of stainless steel is of an excellent stability, capable of working for a long period. And the 5arc-second sensitivity could make the positioning adjustment much more simpler and easier.

MTS-561-L

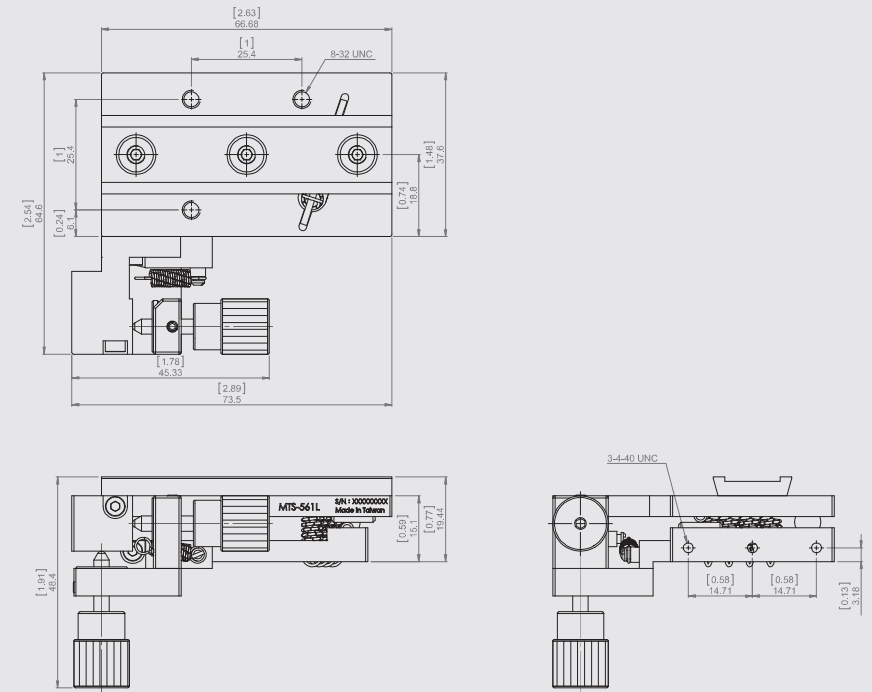

MTS-561-R



Specification

Unit : mm

Specification Axis	Travel Stroke	Sensitivity	Allowable Loading (N)	Material
θx	±5°	Each circular motion equals 5arc-seconds	22	Stainless Steel
θy	±5°			

The body of MTS-561-R made of stainless steel is of an excellent stability, capable of working for a long period. And the 5arc-second sensitivity could make the positioning adjustment much more simpler and easier.

MTS-561-R

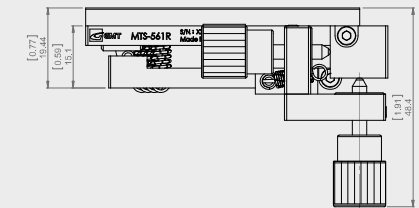
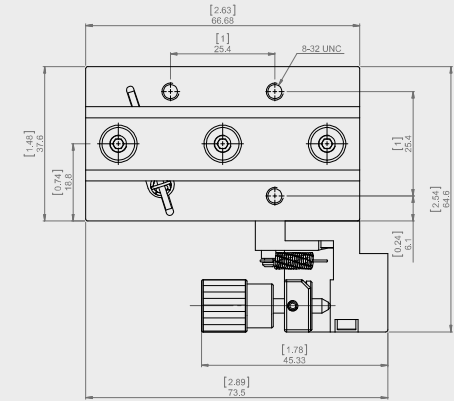
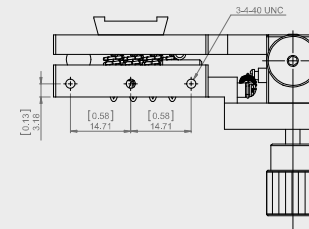

MXY-460AL



Specification

Unit : mm

Specification	Travel Stroke	Resolution (μm)	Allowable Loading(N)	Material
X	0.5 inch(12.7 mm)	10	67	Aluminum alloy
Y	0.5 inch(12.7 mm)			

Thread Hole	Size [inch.(mm)]		
	A	B	C
1/4-20	0.5(12.5)	1(25.4)	

The body of MXY-460AL is aluminum alloyed, and a feature of the series is that containing the GMT crossed roller rails, of which the roller transmission could offer reliable resistance of heavy loading.

MXY-460AL

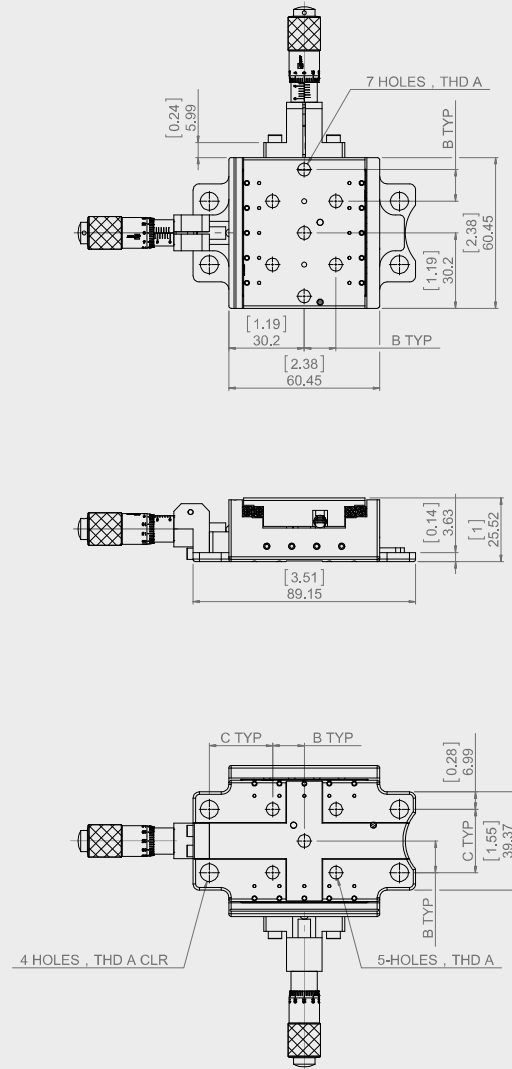

MXZ-460AR



Specification

Unit : mm

Specification Axis	Travel Stroke	Resolution (μm)	Allowable Loading(N)	Material
X	0.5 inch(12.7 mm)	10	67	Aluminum alloy
Y	0.5 inch(12.7 mm)			

Thread Hole	Size [inch.(mm)]		
	A	B	C
	1/4-20	0.5(12.5)	1(25.4)

The body of MXZ-460A-R is aluminum alloyed, and a feature of the series is that containing the GMT crossed roller rails, of which the roller transmission could offer reliable resistance of heavy loading.

MXZ-460AR

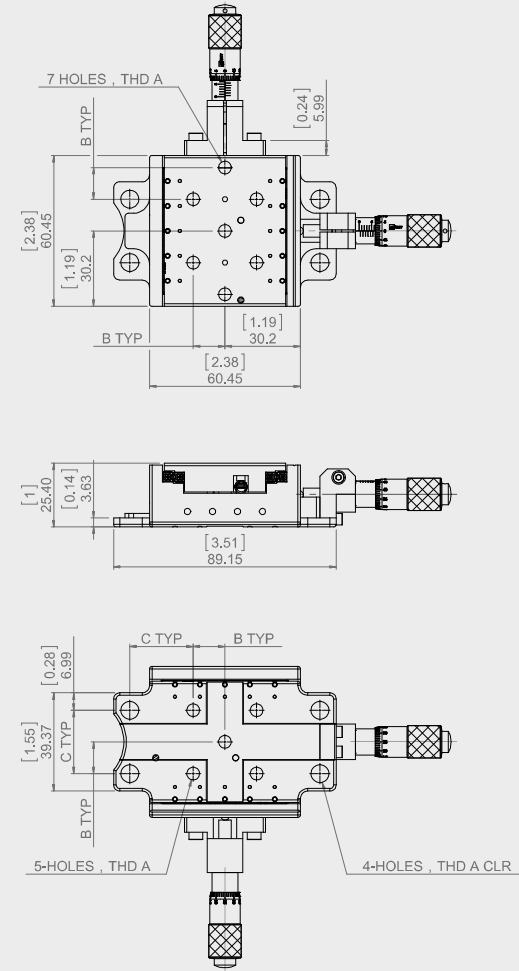

MXYZ-460AL



Specification

Unit : mm

Specification Axis	Travel Stroke	Resolution (μm)	Allowable Loading(N)	Material
X	0.5 inch(12.7 mm)	10	67	Aluminum alloy
Y	0.5 inch(12.7 mm)			
Z	0.5 inch(12.7 mm)			

Thread Hole	Size [inch.(mm)]		
	A	B	C
1/4-20	0.5(12.5)	1(25.4)	

The body of the triple-axis precision stage MXYZ-460AL is aluminum alloyed, and a feature of the series is that containing the GMT crossed roller rails. In addition, the module could be taken apart into a XY-axis stage or XZ-axis stage.

MXYZ-460AL

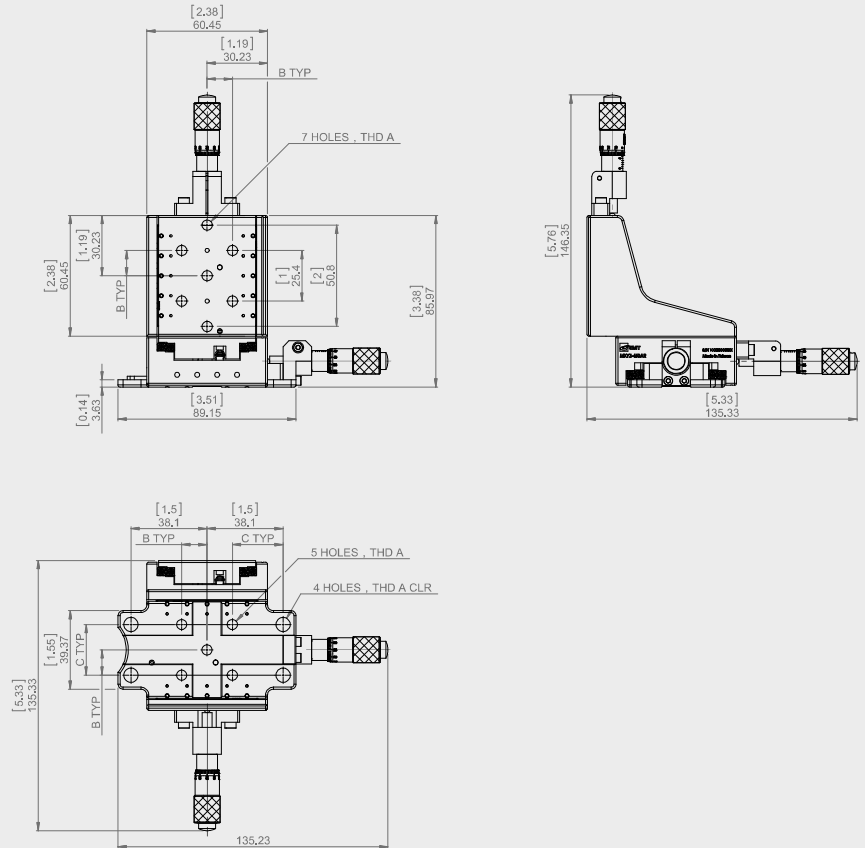

MXYZ-460AR



Specification

Unit : mm

Specification	Travel Stroke	Resolution (μm)	Allowable Loading(N)	Material
X	0.5 inch(12.7 mm)	10	67	Aluminum alloy
Y	0.5 inch(12.7 mm)			
Z	0.5 inch(12.7 mm)			

Thread Hole	Size [inch.(mm)]		
A	B	C	
1/4-20	0.5(12.5)	1(25.4)	

The body of the triple-axis precision stage MXYZ-460AR is aluminum alloyed, and a feature of the series is that containing the GMT crossed roller rails. In addition, the module could be taken apart into a XY-axis stage or XZ-axis stage.

MXYZ-460AR

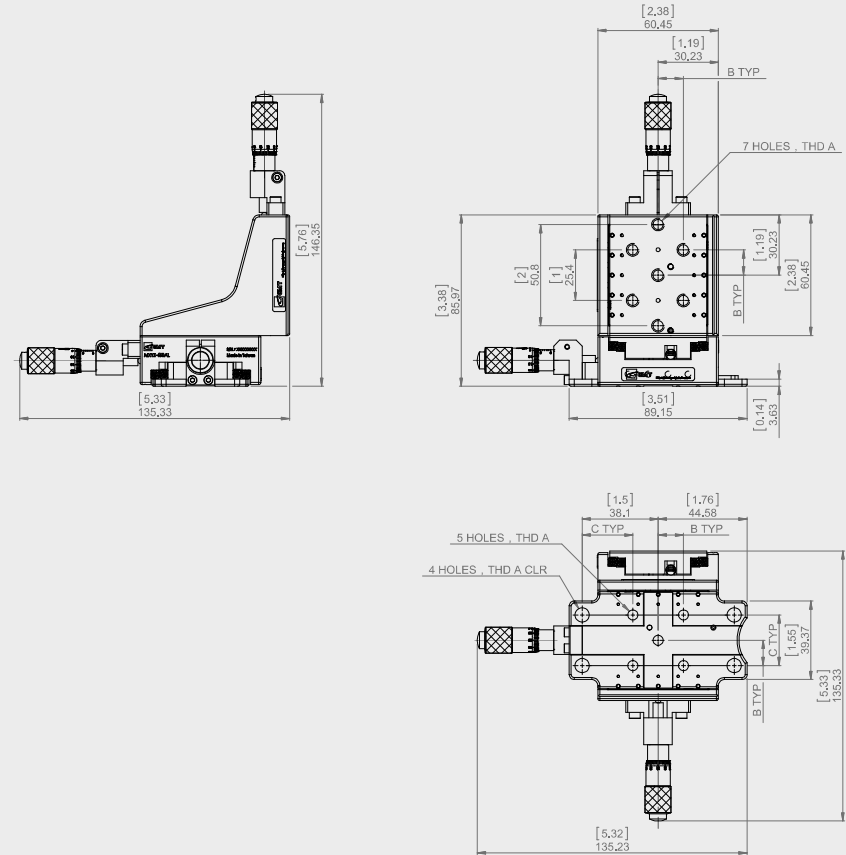

MOVM-S1

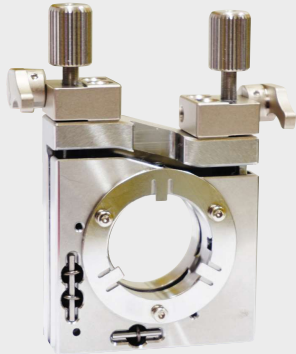

MOVM-S2



Specifications

Model No.	Optics Diameter	Fine Screw Thread	Tilt Range		Sensitivity	Locking	Material	Weight
MOVM-S1	1"	M4x0.25	X :±2.5°	Y :±2.5°	2 arcsec	Both axes	Stainless steel	0.25 kg
MOVM-S2	2"	M6x0.25						0.6 kg

MOVM-S1

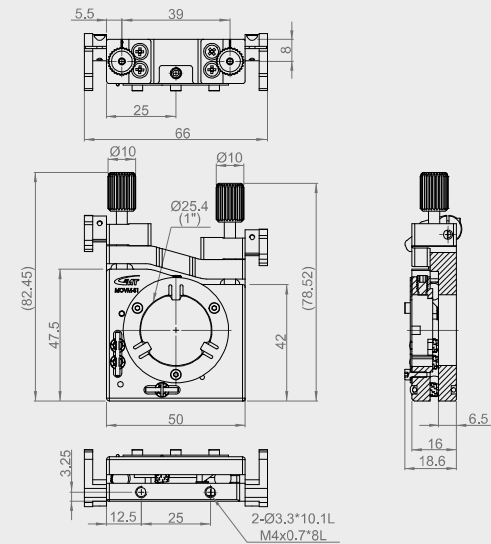

MOVM-S2

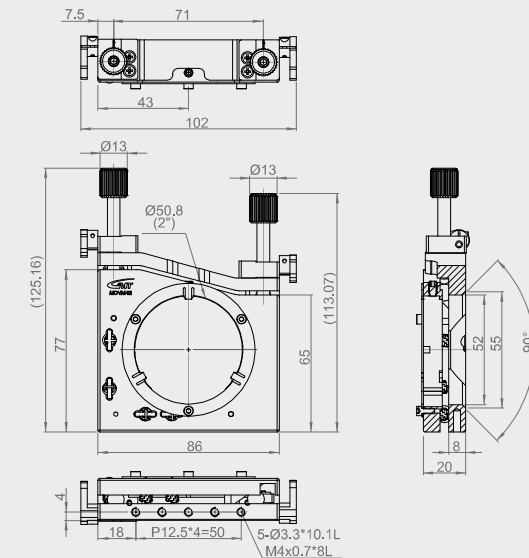

Purpose

The micrometer type is particularly designed for high accuracy positioning devices, such as optical instruments, precisely fine tuning stages, various machine tools, gauging instruments, precisely positioning devices, fixed amount transmissions, etc.

Installation

The heads of the micrometers are classified by their forms as the type of lock screw and set screw.

Fixing form	Lock Screw		Set Screw	
	Installation Diagram			
Shaft Dia.		Ø6 Ø9.525 Ø9.5	Ø6 Ø9.525 Ø9.5	
Mounting Hole Tolerance	G7(+0.004~+0.016)	G7(+0.005~+0.020)	G7(+0.004~+0.016)	G7(+0.005~+0.020)
Notice	The right angle opposite to mounting hole A must be within 0.16/6.5, degrees, or the fixing may be affected		Please notice burrs occurred from inner wall of mounting holes.	
Axial Static Load	8.63~9.8kN(880~1000kgf)		0.69~0.98kN(70~100kgf)	
Remark	Simply and firmly locked		need of locking and tacking process	

★ Loading data is exclusive of maintaining accuracy

Micrometer selection

The considerations of selecting a micrometer might be including gauging range, the shape of gauging face, shaft, and the size of reading axis. Selections should be based on purposes.

Gauging plane selection

The shaft is designed with the most suitable dimension for the body using an allowable tolerance h6. Once the instrument be used for gauging purposes, it is generally suggested to use the plate type; for transferring purposes, using the sphere type could minimize the errors.

MHGS - F N - 13

Model No.

Front Shape

Installation

Travel Stroke

GMT	Measurement Range	Accuracy	Minimum Resolution	Micrometer Tolerance	Vernier	Fronttip		Installation	
						Flate	Round	Lock Screw	Set Screw
MHGS-FN-6.5	0~6.5	0.005	0.01	± 2	Positive scale	●		●	
MHGS-FP-6.5						●			●
MHGS-SN-6.5							●	●	
MHGS-SP-6.5						●		●	
MHGS-FN-13	0~13					●		●	
MHGS-FP-13						●			●
MHGS-SN-13							●	●	
MHGS-SP-13						●		●	
MHGS-FN-15	0~15					●		●	
MHGS-FP-15						●			●
MHGS-SN-15							●	●	
MHGS-SP-15						●		●	
MHGS-FN-25	0~25					●		●	
MHGS-FP-25						●			●
MHGS-SN-25							●	●	
MHGS-SP-25		●		●					
MHGS-FN-50	0~50	●		●					
MHGS-FP-50		●			●				
MHGS-SN-50			●	●					
MHGS-SP-50			●		●				

- MHGS type (standard type) is mostly used worldwide.
- Gauging face material: SKS3(Hardness: above HRC60)
- Scale surface finish: Hard chrome-plating

MHGS-FN-6.5

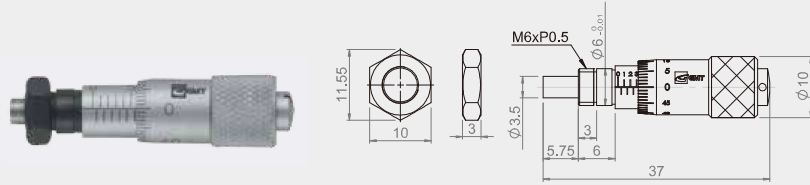

MHGS-FP-6.5

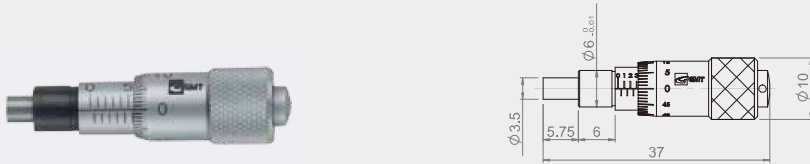

MHGS-SN-6.5

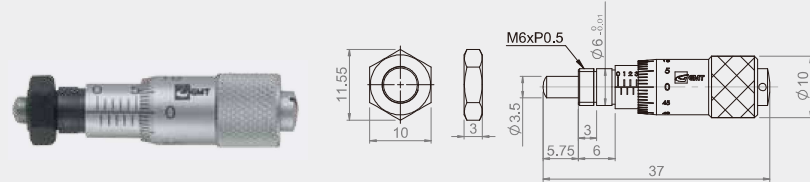

MHGS-SP-6.5

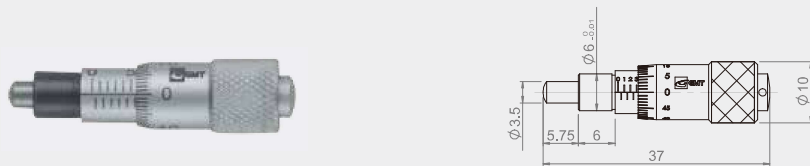

MHGS-FN-13

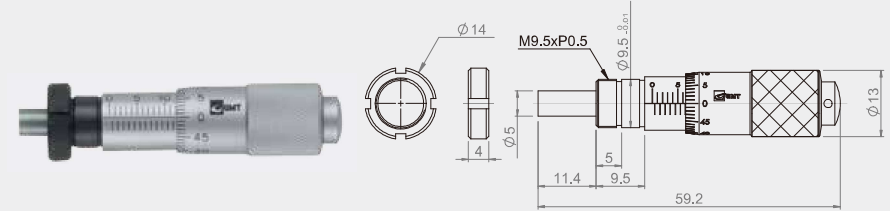

MHGS-FP-13

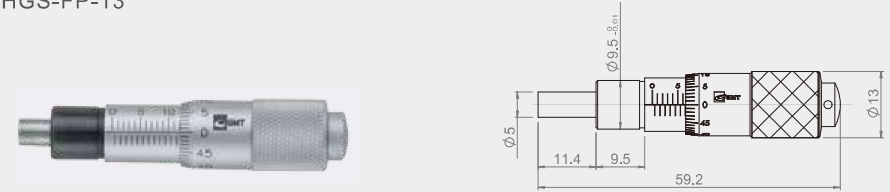

MHGS-SN-13

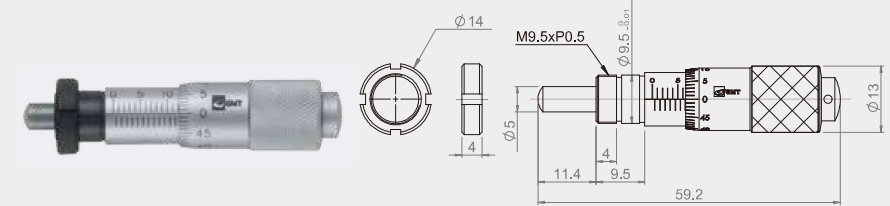

MHGS-SP-13

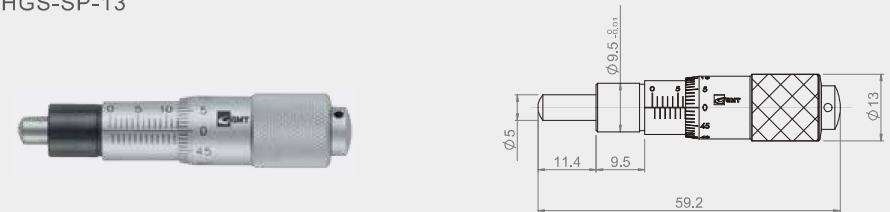

MHGS-FN-15

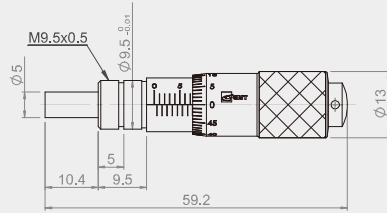

Screw ptions please refer to : MHGS-FN-13

MHGS-FP-15

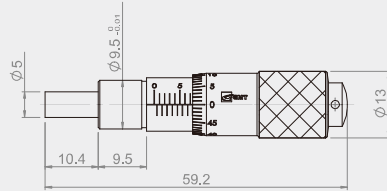

MHGS-SN-15

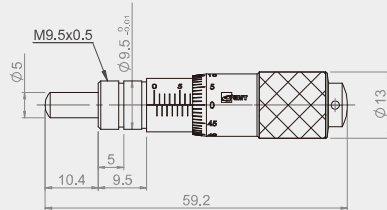

Screw options please refer to : MHGS-FN-13

MHGS-SP-15

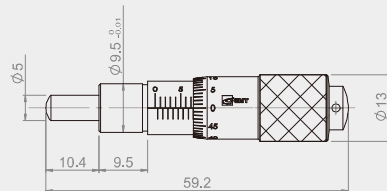

MHGS-FN-25

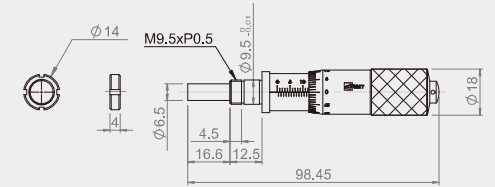

MHGS-FP-25

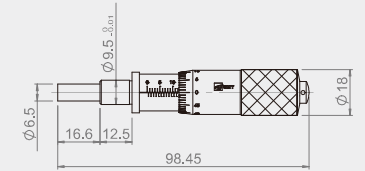

MHGS-SN-25

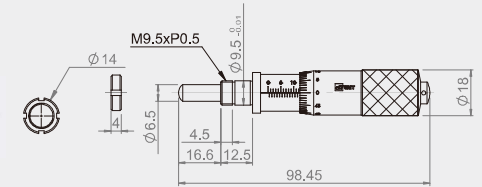

MHGS-SP-25

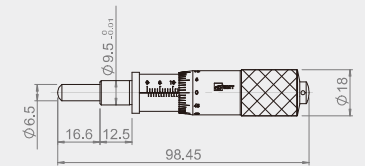

MHGS-FN-50

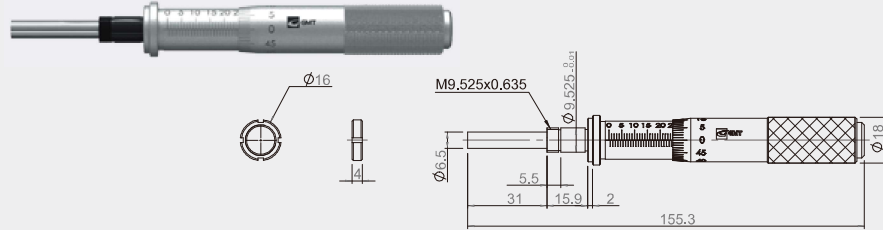

MHGS-FP-50

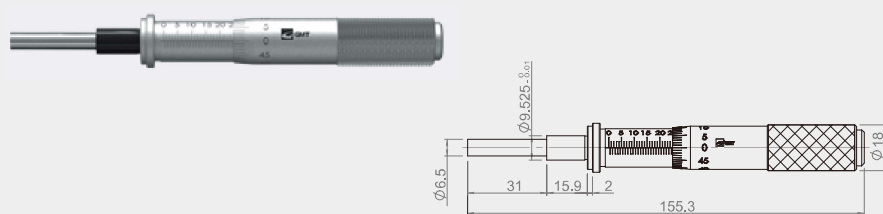

MHGS-SN-50

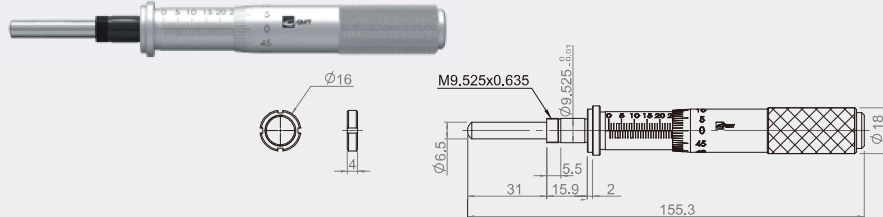

MHGS-SP-50

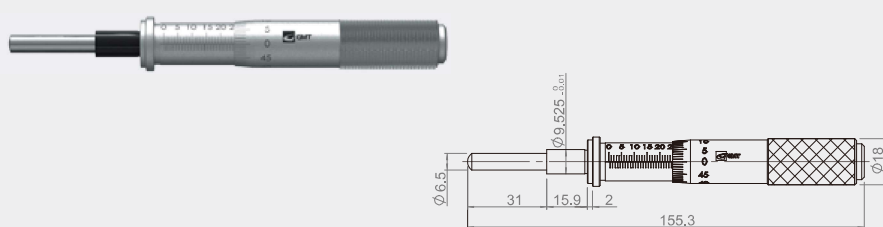

MHGS-SP-6.5A(B)

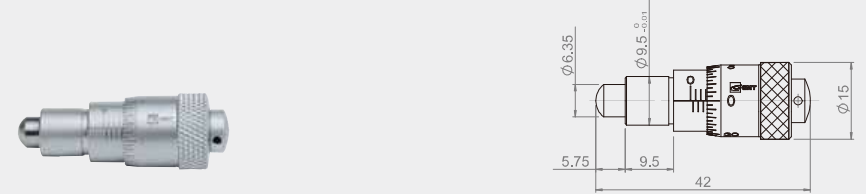

PITCH : A(0.25mm) ; B(0.5mm)

MHGS-FN-25A

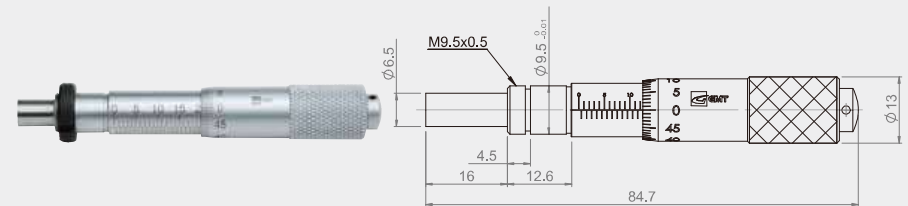

Screw options please refer to : MHGS-FN-13

MHGS-SN-25A

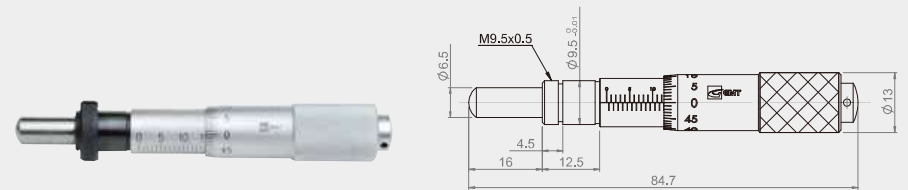

Screw options please refer to : MHGS-FN-13

MHGS-FN-1/2"

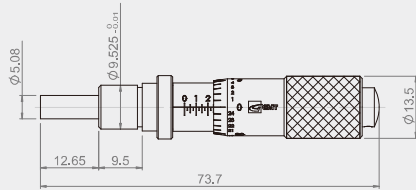

MHGS-FN-2"

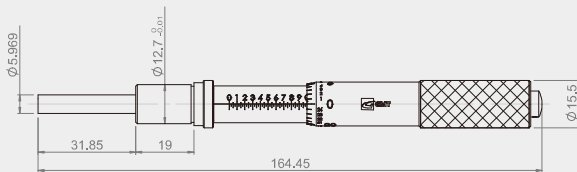

EMHGS-FN-13

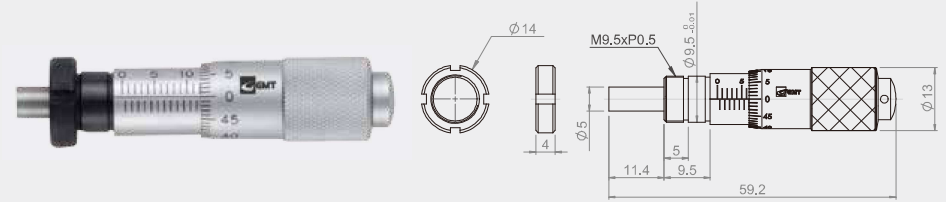

EMHGS-FP-13



EMHGS-SN-13

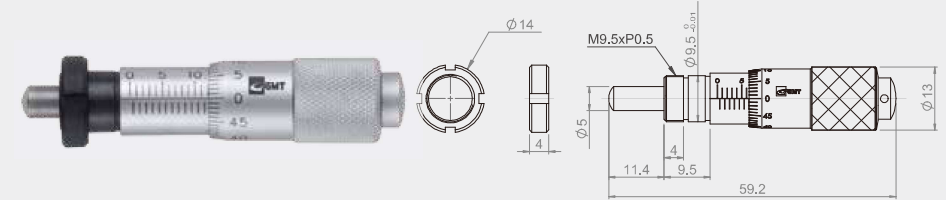

EMHGS-SP-13



EMHGS-FN-25

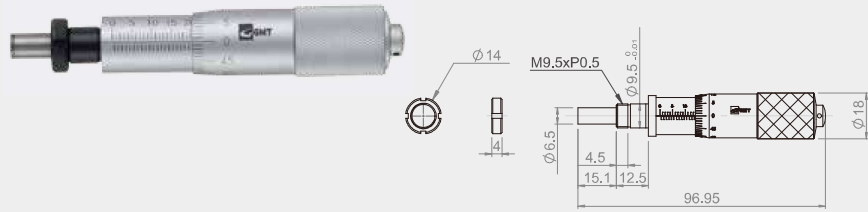

EMHGS-FP-25



EMHGS-SN-25

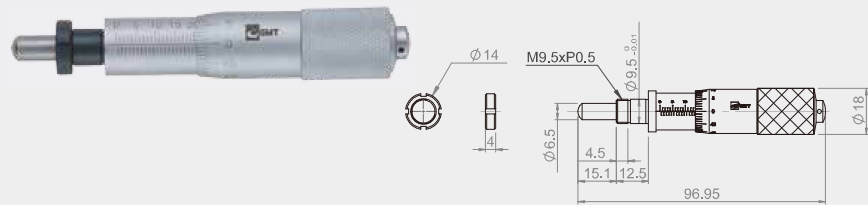

EMHGS-SP-25





Usage

Feeding screw: Can be applied to the mechanical structures which performing general precision movement, adjusting devices, etc. Widely used in various applications because of the lower cost in contrast to the micrometer.

Installation

There are two types of locking available: Threaded and Cylinder.

Lock Type	Threaded Locking	Cylinder Locking
Installation method		
Axis diameter	Ø6mm、Ø9.5mm	
Tolerance suggestion for installation hole embedding	G7 [+ 0.004 ~ + 0.020]	
Remark	It's simple, rapid and lock tightly	Use set screw to lock with assisting parts

★ Once the feeding screw be used for transferring purposes, using the sphere type could minimize the errors.

Common Used Lock (3-d Diagrams):

Thread Type



Cylinder Type



★ The diagrams are used as reference, the locking type can be customized.

PS 1 R C - 13

Model	Knob Type	Lock Type	Stroke / Guiding [mm]	Code 《Travel》
P: Precision S: Screw	1 : Pattern 2 : Hexagon Socket	M : Thread Type R : Cylinder Type	N : General Type / 1 C : Standard Type / 0.5	07 《7》 13 《13》 25 《25》

Feeding Screw Selection Table

GMT Model	Travel Stroke Range mm	Accuracy mm	Minimum Reading Vernier	Knob Type		Page	
				Pattern	Hexagon Socket		
PS1R □-	0.7	0 ~ 7	0.03	0.1 mm / Vernier	●		P0329
	1.3	0 ~ 13			●		
	2.5	0 ~ 25			●		
PS2R □-	0.7	0 ~ 7				●	P0329 } P0330
	1.3	0 ~ 13				●	
	2.5	0 ~ 25				●	
PS1M □-	0.7	0 ~ 7				●	P0331
	1.3	0 ~ 13				●	
	2.5	0 ~ 25				●	
PS2M □-	0.7	0 ~ 7			P0331		
	1.3	0 ~ 13		●			
	2.5	0 ~ 25		●			

★ notice

- PS1M and PS2M series would be attached with the particular wrench.
- The thread and bushing parts are both in high precision and able to inhibit shaking.
- Thread part material : SUS303 ◦

Model No : PS1R □—07 ; Threaded Screw : M3x [Pitch : 0.25 or 0.5]

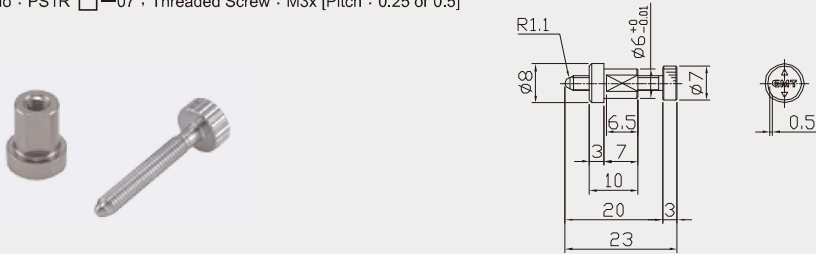

Model No : PS1R □—13 ; Threaded Screw : M6x [Pitch : 0.25 or 0.5]

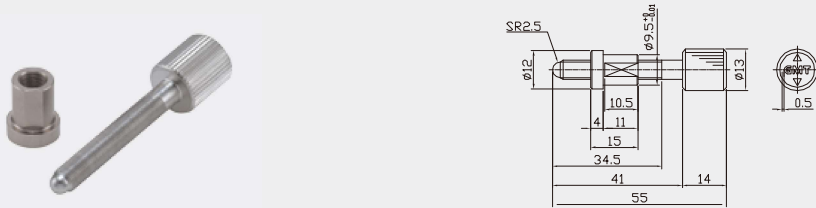

Model No : PS1R □—25 ; Threaded Screw : M6x [Pitch : 0.5 or 1]

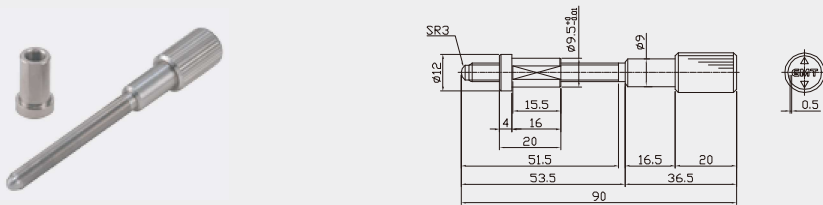

Model No : PS2R □—07 ; Threaded Screw : M3x [Pitch : 0.25 or 0.5]



Model No : PS2R □—13 ; Threaded Screw : M6x [Pitch : 0.25 Or 0.5]

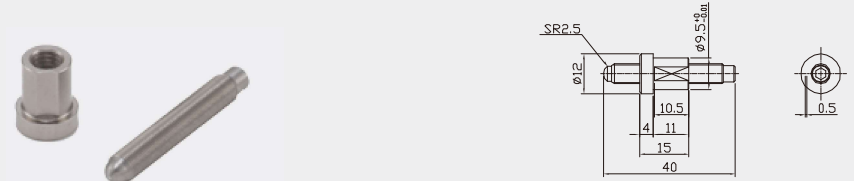

Model No : PS2R □—25 ; Threaded Screw : M6x [Pitch : 0.5 or 1]



Model No : PS1M □—07 ; Threaded Screw : M3x [Pitch : 0.25 or 0.5]

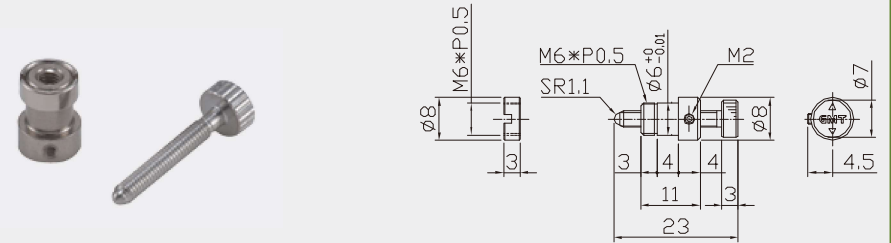

Model No : PS1M □—13 ; Threaded Screw : M6x [Pitch : 0.25 or 0.5]

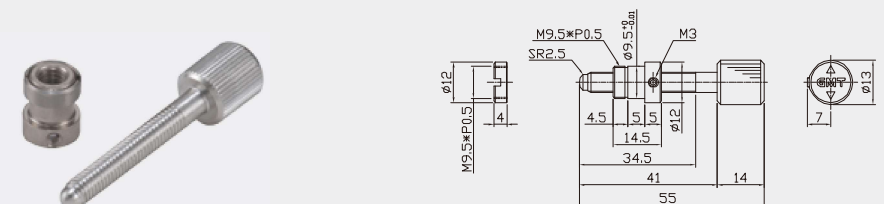

Model No : PS1M □—25 ; Threaded Screw : M6x [Pitch : 0.5 or 1]

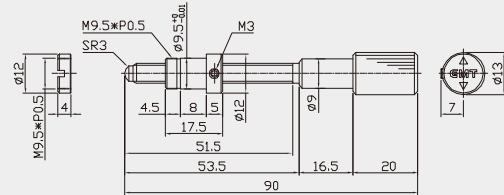

Model No : PS2M □—07 ; Threaded Screw : M3x [Pitch : 0.25 or 0.5]

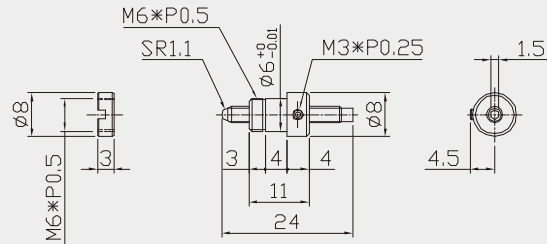

Model No : PS2M □—13 ; Threaded Screw : M6x [Pitch : 0.25 or 0.5]

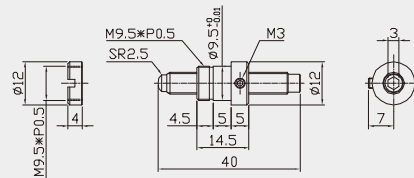

Model No : PS2M □—25 ; Threaded Screw : M6x [Pitch : 0.5 or 1]

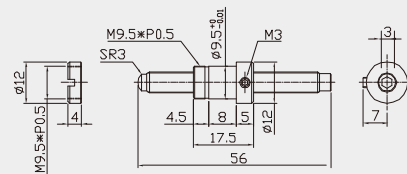

Model Specification

GACT	-	S	-	N	-	6.5
Model No.		Pilot Shape		Installation		Stroke
GACT : Actuator		F : Flat measuring surface S : Spherical measuring surface		N : Locknuts P : Set screws		6.5 : 6.5 mm

Model No.		GACT-SP-6.5	GACT-SN-6.5	GACT-FP-6.5	GACT-FN-6.5
Mechanical Specifications	Measuring Range	0 ~ 6.5			
	Transmission	Precision thread M6x0.5P			
	Body Weight(kg)	0.129			
	Pilot Shape	F : Flat measuring surface / S : Spherical measuring surface			
	Installation	N : Locknuts / P : set screws			
	Scale Shape	N scale			
Precision Specifications	Material / Color	Actuator : aluminum ally / black anodized			
	Dpi(Pulse)	Full / Half(mm)		0.0025 / 0.00125	
	Veneered Positioning Accuracy(mm)	0.01 mm			
	Repeat Positioning Accuracy	0.003			
	Allowable Load(N)	29.4			
	Maximum Speed(mm / sec)	2			
Electrical Specifications	Motor	Motor Model / Shaft Numbers	2-phase stepping / 20□ dual extension shafts		
		Manufacturers	Orientalmotor / GMT		
		Model No.	CVK213BK / 2MS-N20D33A		
	Connector	Actuator cable connector	15Pin Public-side connector D-SUB		

GACT series

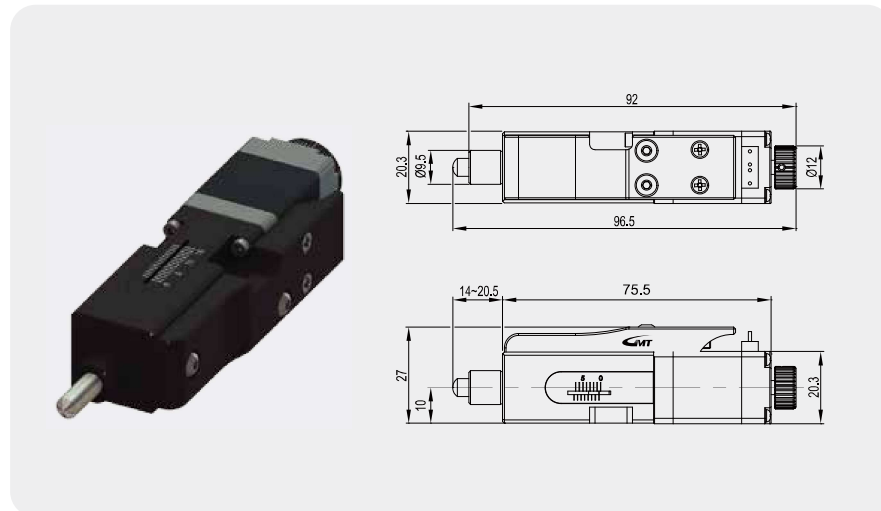

© GACT-SP-13 *
© If institutions qualify for the HRS, please inform.

Model Specification

GACT	-	S	-	N	-	13
Model No.		Pilot Shape		Installation		Stroke
GACT : Actuator		F : Flat measuring surface S : Spherical measuring surface		N : Locknuts P : Set screws		13 : 13 mm

Model No.		GACT-SP-13	GACT-SN-13	GACT-FP-13	GACT-FN-13
Mechanical Specifications	Measuring Range	0 ~ 13			
	Transmission	Precision thread M6x0.5P			
	Body Weight(kg)	0.156 kg			
	Pilot Shape	F : Flat measuring surface / S : Spherical measuring surface			
	Installation	N : Locknuts / P : set screws			
	Scale Shape	N scale			
Precision Specifications	Material / Color	Actuator : aluminum ally / black anodized			
	Dpi(Pulse)	Full / Half(mm)		0.0025 / 0.00125	
	Veneered Positioning Accuracy(mm)	0.01 mm			
	Repeat Positioning Accuracy	0.003			
	Allowable Load(N)	29.4			
	Maximum Speed(mm / sec)	2			
Electrical Specifications	Motor	Motor Model / Shaft Numbers	2-phase stepping / 20□ dual extension shafts		
		Manufacturers	Orientalmotor / GMT		
		Model No.	CVK213BK / 2MS-N20D33A		
	Connector	Actuator cable connector	15Pin Public-side connector D-SUB		

GACT series

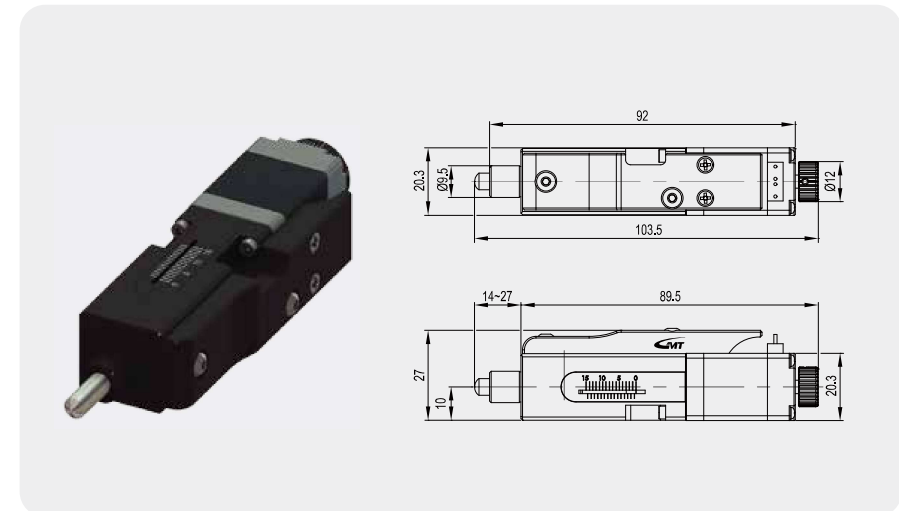

If institutions qualify for the HRS, please inform.

Model Specification

GACT	S	N	25
Model No.	Pilot Shape	Installation	Stroke
GACT : Actuator	F : Flat measuring surface S : Spherical measuring surface	N : Locknuts P : Set screws	25 : 25 mm

Model No.		GACT-SP-25	GACT-SN-25	GACT-FP-25	GACT-FN-25
Mechanical Specifications	Measuring Range	0 ~ 25			
	Transmission	Precision thread M6x0.5P			
	Body Weight(kg)	0.163kg			
	Pilot Shape	F : Flat measuring surface / S : Spherical measuring surface			
	Installation	N : Locknuts / P : set screws			
Precision Specifications	Scale Shape	N scale			
	Material / Color	Actuator : aluminum ally / black anodized			
	Dpi(Pulse)	Full / Half(mm)	0.0025 mm / 0.00125 mm		
	Veneered Positioning Accuracy(mm)	0.01 mm			
	Repeat Positioning Accuracy	0.003			
Electrical Specifications	Motor	Allowable Load(N)	29.4		
		Maximum Speed(mm / sec)	2		
		Motor Model / Shaft Numbers	2-phase stepping / 20 dual extension shafts		
	Connector	Manufacturers	Orientalmotor / GMT		
		Model No.	CVK213BK / 2MS-N20D33A		
Connector		Actuator cable connector	15Pin Public-side connector D-SUB		

GACT series

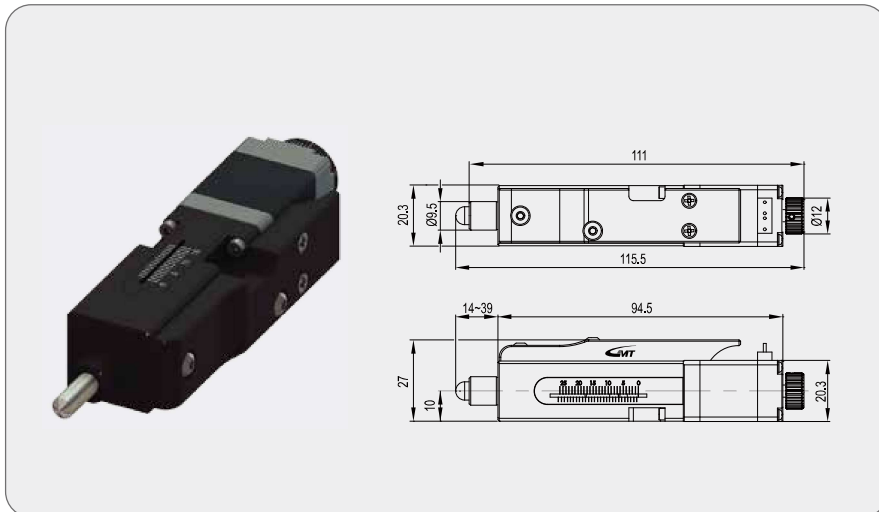

© GACT-SP-13 *
© If institutions qualify for the HRS, please inform.

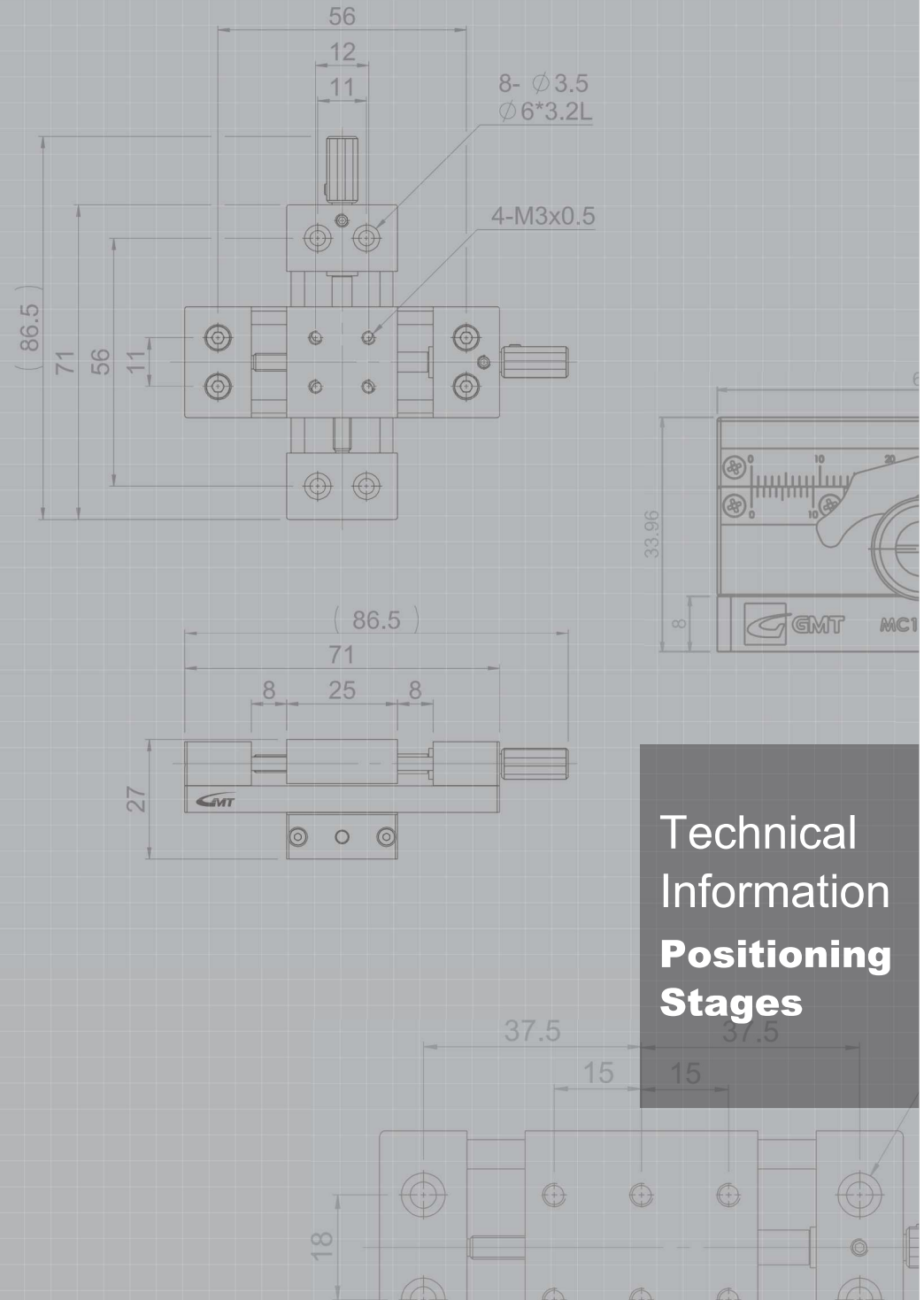

Technical Information
Positioning Stages

Simplified & rapid adjustment module for CCD monitoring.



Measuring module for membrane thickness of transparent material.

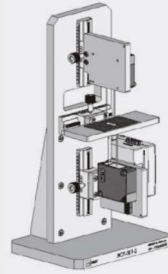

Multiple axes module for Universal fine tuning.

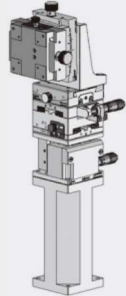

Multi-axes, micro-adjustment module.

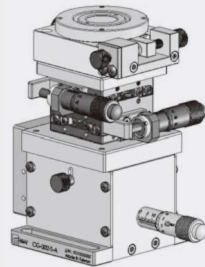

Micro-alignment module of CCD fabricated equipment.

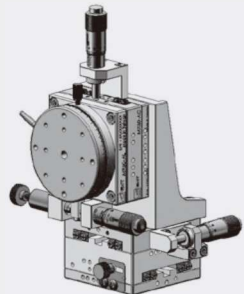

Micro-alignment module for AOI system.

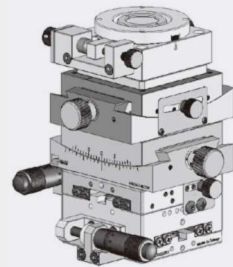

XYR-axis alignment stage module.

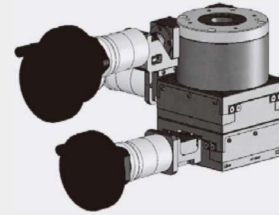

LED wafer characteristic inspection stage module.

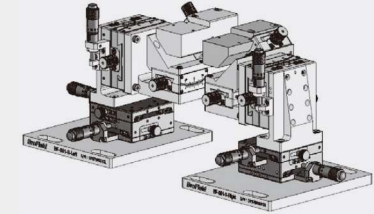

Profile measuring module.

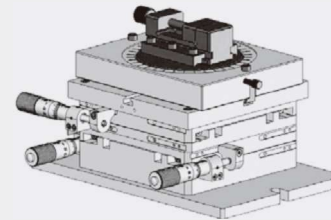

Stage module for surface roughness measuring.

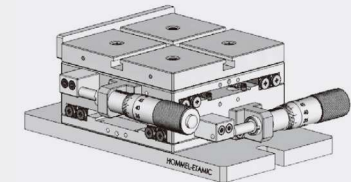

Single axis movement module of large-scale alignment stage.

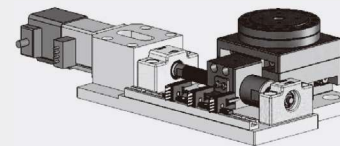

Lathing stage module equipped with mini-size motors

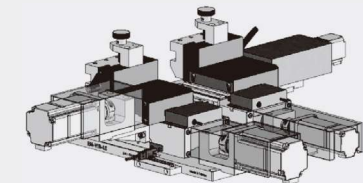

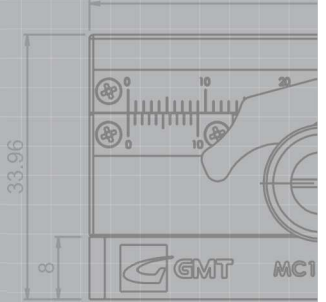
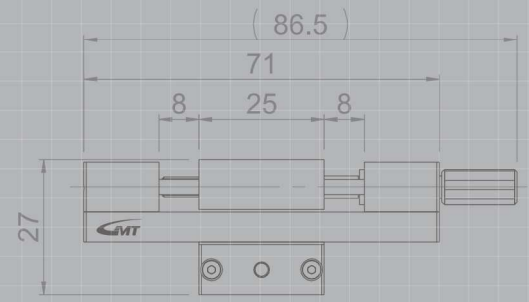
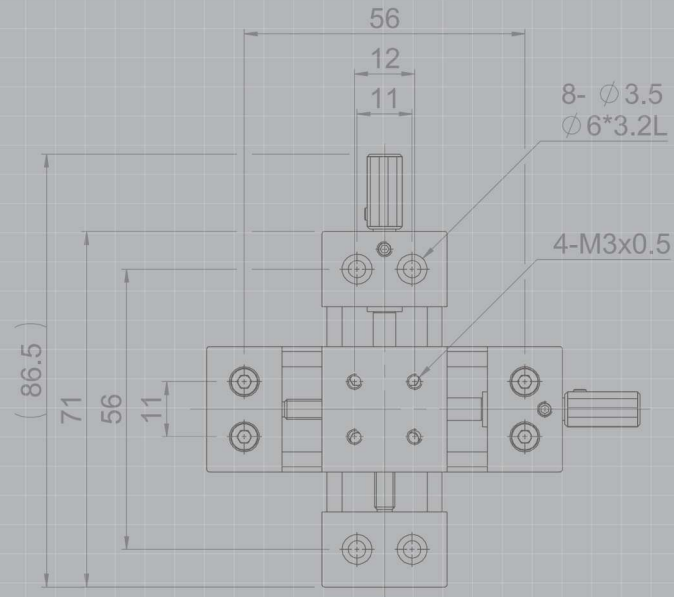

**Technical
Information
Manual
Positioners**

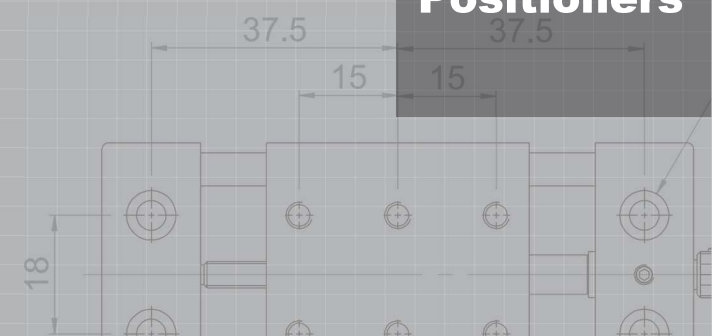

Reference Table of Basic Shaft Fitting

Unit : $\mu=0.001\text{mm}$

Basic Shaft	Bore Tolerance Classes																				
	Clearance fit						Transition fit				Interference fit										
							H6	JS6	K6	M6	N6*	P6					R7	S7	T7	U7	X7
h5																					
h6					F6	G6	H6	JS6	K6	M6	N6*	P6*									
h7				E7	F7		H7	JS7	K7	M7	N7	P7*									
h8					F8		H8														
h9				D8	E8		H8														
				D9	E9		H9														
				D8	E8		H8														
				C9	D9	E9	H9														
	B10	C10	D10																		

★ There may be exceptions in these fits depending on dimension classes.

Reference Table for Basic Bore Fitting

Unit : $\mu=0.001\text{mm}$

Basic Bore	Shaft Tolerance Classes																				
	Clearance fit						Transition fit				Interference fit										
							g5	h5	js5	k5	m5					n6*	p6*	r6*	s6	t6	u6
H6							g5	h5	js5	k5	m5				n6*	p6*					
H7							f6	g6	h6	js6	k6	m6			n6	p6*	r6*	s6	t6	u6	x6
H8							e7	f7	h7	js7											
H9							e8	f8	h8												
H9							d9	e9	h8												
H9							d8	e8	h9												
H9							d9	e9	h8												
H9							c9	d9	e9												
H10							b9	c9	d9												

★ There may be exceptions in these fits depending on dimension classes.

Reference Table of Shaft Tolerance

Unit : $\mu=0.001\text{mm}$

Basic Dimensions (mm)		Tolerance Zone Class for Shaft																		
		b9	c9	d8	d9	e7	e8	e9	f6	f7	f8	g5	g6	h5	h6	h7	h8	h9		
—	≤3	-140 -165	-60 -85	-20 -34	-20 -45	-14 -24	-14 -28	-14 -39	-6 -12	-6 -16	-2 -6	-2 -8	0 -4	0 -6	0 -10	0 -14	0 -25			
>3	≤6	-140 -170	-70 -100	-30 -48	-30 -60	-20 -32	-20 -38	-20 -50	-10 -18	-10 -22	-10 -28	-4 -12	-4 -12	0 -5	0 -8	0 -12	0 -18	0 -30		
>6	≤10	-150 -186	-80 -116	-40 -62	-40 -76	-25 -40	-25 -47	-25 -61	-13 -22	-13 -28	-13 -35	-5 -11	-5 -14	0 -6	0 -9	0 -15	0 -22	0 -36		
>10	≤14	-150 -193	-95 -138	-50 -77	-50 -93	-32 -50	-32 -59	-32 -75	-16 -27	-16 -34	-16 -43	-6 -14	-6 -17	0 -8	0 -11	0 -18	0 -27	0 -43		
>14	≤18	-160 -212	-110 -162	-65 -98	-65 -117	-40 -61	-40 -73	-40 -92	-20 -33	-20 -41	-20 -53	-7 -16	-7 -20	0 -9	0 -13	0 -21	0 -33	0 -52		
>18	≤24	-170 -232	-120 -182	-80 -119	-80 -142	-50 -75	-50 -89	-50 -112	-25 -41	-25 -50	-25 -64	-9 -20	-9 -25	0 -11	0 -16	0 -25	0 -39	0 -62		
>24	≤30	-180 -242	-130 -192	-90 -146	-90 -174	-60 -90	-60 -106	-60 -134	-30 -49	-30 -60	-30 -76	-10 -23	-10 -29	0 -13	0 -19	0 -30	0 -46	0 -74		
>30	≤40	-190 -264	-140 -214	-100 -146	-100 -174	-70 -90	-70 -106	-70 -134	-40 -58	-40 -68	-40 -83	-14 -32	-14 -39	0 -18	0 -25	0 -40	0 -63	0 -100		
>40	≤50	-200 -274	-150 -224	-110 -146	-110 -174	-80 -90	-80 -106	-80 -134	-50 -68	-50 -78	-50 -93	-15 -27	-15 -34	0 -15	0 -22	0 -35	0 -54	0 -87		
>50	≤65	-220 -307	-170 -257	-120 -174	-120 -207	-90 -107	-90 -126	-90 -159	-60 -78	-60 -88	-60 -106	-18 -32	-18 -39	0 -18	0 -25	0 -40	0 -63	0 -100		
>65	≤80	-240 -327	-180 -267	-140 -208	-140 -245	-110 -125	-110 -148	-110 -185	-80 -98	-80 -108	-80 -137	-20 -35	-20 -44	0 -20	0 -29	0 -46	0 -72	0 -115		
>80	≤100	-260 -360	-200 -300	-160 -208	-160 -245	-130 -146	-130 -172	-130 -215	-100 -118	-100 -128	-100 -157	-15 -32	-15 -41	0 -20	0 -29	0 -46	0 -72	0 -115		
>100	≤120	-280 -380	-220 -320	-180 -240	-180 -277	-150 -162	-150 -191	-150 -240	-120 -138	-120 -148	-120 -177	-18 -35	-18 -44	0 -20	0 -29	0 -46	0 -72	0 -115		
>120	≤140	-310 -410	-230 -330	-190 -240	-190 -277	-160 -172	-160 -201	-160 -250	-130 -148	-130 -158	-130 -187	-18 -35	-18 -44	0 -20	0 -29	0 -46	0 -72	0 -115		
>140	≤160	-340 -455	-240 -355	-200 -260	-200 -297	-170 -182	-170 -211	-170 -260	-140 -158	-140 -168	-140 -197	-18 -35	-18 -44	0 -20	0 -29	0 -46	0 -72	0 -115		
>160	≤180	-380 -495	-260 -375	-220 -280	-220 -317	-190 -202	-190 -231	-190 -280	-160 -178	-160 -188	-160 -217	-18 -35	-18 -44	0 -20	0 -29	0 -46	0 -72	0 -115		
>180	≤200	-420 -535	-280 -395	-240 -300	-240 -337	-210 -222	-210 -261	-210 -310	-180 -198	-180 -208	-180 -237	-18 -35	-18 -44	0 -20	0 -29	0 -46	0 -72	0 -115		
>200	≤225	-480 -610	-300 -430	-260 -320	-260 -357	-230 -242	-230 -281	-230 -330	-200 -218	-200 -228	-200 -257	-18 -35	-18 -44	0 -20	0 -29	0 -46	0 -72	0 -115		
>225	≤250	-540 -670	-330 -460	-290 -350	-290 -387	-260 -272	-260 -311	-260 -360	-230 -248	-230 -258	-230 -287	-18 -35	-18 -44	0 -20	0 -29	0 -46	0 -72	0 -115		
>250	≤280	-600 -740	-360 -500	-320 -380	-320 -417	-290 -302	-290 -341	-290 -390	-260 -278	-260 -288	-260 -317	-18 -35	-18 -44	0 -20	0 -29	0 -46	0 -72	0 -115		
>280	≤315	-680 -820	-400 -540	-360 -420	-360 -457	-330 -342	-330 -381	-330 -430	-300 -318	-300 -328	-300 -357	-18 -35	-18 -44	0 -20	0 -29	0 -46	0 -72	0 -115		
>315	≤355	-760 -915	-440 -595	-400 -460	-400 -497	-370 -382	-370 -431	-370 -480	-340 -358	-340 -368	-340 -397	-18 -35	-18 -44	0 -20	0 -29	0 -46	0 -72	0 -115		
>355	≤400	-840 -995	-480 -635	-440 -500	-440 -537	-410 -422	-410 -471	-410 -520	-380 -398	-380 -408	-380 -437	-18 -35	-18 -44	0 -20	0 -29	0 -46	0 -72	0 -115		
>400	≤450	-940 -1115	-540 -715	-500 -560	-500 -597	-470 -482	-470 -531	-470 -580	-440 -458	-440 -478	-440 -517	-18 -35	-18 -44	0 -20	0 -29	0 -46	0 -72	0 -115		
>450	≤500	-1040 -1235	-600 -795	-560 -620	-560 -657	-530 -542	-530 -591	-530 -640	-500 -518	-500 -538	-500 -577	-18 -35	-18 -44	0 -20	0 -29	0 -46	0 -72	0 -115		

★ In each column, the upper value is the upper dimensional tolerance, and the lower figure is the lower dimensional tolerance.

Reference Table of Bore Tolerance

Unit : μ=0.001mm

Basic Dimensions (mm)	Tolerance Zone Class for Bore																			
	B10	C9	C10	D8	D9	D10	E7	E8	E9	F6	F7	F8	G6	G7	H6	H7	H8	H9	H10	
—	3	+180 +140	+85 +60	+100 +60	+34 +20	+45 +20	+60 +20	+24 +14	+28 +14	+39 +14	+12 +6	+16 +6	+20 +6	+8 +2	+12 +2	+6 0	+10 0	+14 0	+25 0	+40 0
>3	≤6	+188 +140	+100 +70	+118 +70	+48 +30	+60 +30	+78 +30	+32 +20	+38 +20	+50 +20	+18 +10	+22 +10	+28 +10	+12 +4	+16 +4	+8 0	+12 0	+18 0	+30 0	+48 0
>6	≤10	+208 +150	+116 +80	+138 +80	+62 +40	+76 +40	+98 +40	+40 +25	+47 +25	+61 +25	+22 +13	+28 +13	+35 +13	+14 +5	+20 +5	+9 0	+15 0	+22 0	+36 0	+58 0
>10	≤14	+220 +150	+138 +95	+165 +95	+77 +50	+93 +50	+120 +50	+50 +32	+59 +32	+75 +32	+27 +16	+34 +16	+43 +16	+17 +6	+24 +6	+11 0	+18 0	+27 0	+43 0	+70 0
>14	≤18	+244 +160	+162 +110	+194 +110	+98 +65	+117 +65	+149 +65	+61 +40	+73 +40	+90 +40	+33 +20	+41 +20	+53 +20	+20 +7	+28 +7	+13 0	+21 0	+33 0	+52 0	+84 0
>18	≤24	+270 +170	+182 +120	+220 +120	+119 +80	+142 +80	+180 +80	+75 +50	+89 +50	+112 +50	+41 +25	+50 +25	+64 +25	+25 +9	+34 +9	+16 0	+25 0	+39 0	+62 0	+100 0
>24	≤30	+280 +180	+192 +130	+230 +130	+146 +100	+174 +100	+220 +100	+90 +60	+106 +60	+134 +60	+49 +30	+60 +30	+76 +30	+29 +10	+40 +10	+19 0	+30 0	+46 0	+74 0	+120 0
>30	≤40	+310 +190	+214 +140	+260 +140	+174 +100	+207 +100	+260 +100	+107 +60	+126 +60	+159 +60	+58 +36	+71 +36	+90 +36	+34 +12	+47 +12	+22 0	+35 0	+54 0	+87 0	+140 0
>40	≤50	+320 +200	+224 +150	+270 +150	+174 +100	+207 +100	+260 +100	+107 +60	+126 +60	+159 +60	+58 +36	+71 +36	+90 +36	+34 +12	+47 +12	+22 0	+35 0	+54 0	+87 0	+140 0
>50	≤65	+360 +220	+257 +170	+310 +170	+174 +100	+207 +100	+260 +100	+107 +60	+126 +60	+159 +60	+58 +36	+71 +36	+90 +36	+34 +12	+47 +12	+22 0	+35 0	+54 0	+87 0	+140 0
>65	≤80	+380 +240	+267 +180	+320 +180	+174 +100	+207 +100	+260 +100	+107 +60	+126 +60	+159 +60	+58 +36	+71 +36	+90 +36	+34 +12	+47 +12	+22 0	+35 0	+54 0	+87 0	+140 0
>80	≤100	+420 +260	+300 +200	+360 +200	+174 +100	+207 +100	+260 +100	+107 +60	+126 +60	+159 +60	+58 +36	+71 +36	+90 +36	+34 +12	+47 +12	+22 0	+35 0	+54 0	+87 0	+140 0
>100	≤120	+440 +280	+310 +210	+370 +210	+174 +100	+207 +100	+260 +100	+107 +60	+126 +60	+159 +60	+58 +36	+71 +36	+90 +36	+34 +12	+47 +12	+22 0	+35 0	+54 0	+87 0	+140 0
>120	≤140	+470 +310	+330 +230	+390 +230	+174 +100	+207 +100	+260 +100	+107 +60	+126 +60	+159 +60	+58 +36	+71 +36	+90 +36	+34 +12	+47 +12	+22 0	+35 0	+54 0	+87 0	+140 0
>140	≤160	+525 +340	+255 +240	+425 +240	+174 +100	+207 +100	+260 +100	+107 +60	+126 +60	+159 +60	+58 +36	+71 +36	+90 +36	+34 +12	+47 +12	+22 0	+35 0	+54 0	+87 0	+140 0
>160	≤180	+565 +380	+375 +260	+445 +260	+174 +100	+207 +100	+260 +100	+107 +60	+126 +60	+159 +60	+58 +36	+71 +36	+90 +36	+34 +12	+47 +12	+22 0	+35 0	+54 0	+87 0	+140 0
>180	≤200	+605 +420	+395 +280	+465 +280	+174 +100	+207 +100	+260 +100	+107 +60	+126 +60	+159 +60	+58 +36	+71 +36	+90 +36	+34 +12	+47 +12	+22 0	+35 0	+54 0	+87 0	+140 0
>200	≤225	+690 +480	+430 +300	+510 +300	+174 +100	+207 +100	+260 +100	+107 +60	+126 +60	+159 +60	+58 +36	+71 +36	+90 +36	+34 +12	+47 +12	+22 0	+35 0	+54 0	+87 0	+140 0
>225	≤250	+750 +540	+460 +330	+540 +330	+174 +100	+207 +100	+260 +100	+107 +60	+126 +60	+159 +60	+58 +36	+71 +36	+90 +36	+34 +12	+47 +12	+22 0	+35 0	+54 0	+87 0	+140 0
>250	≤280	+830 +600	+500 +360	+590 +360	+174 +100	+207 +100	+260 +100	+107 +60	+126 +60	+159 +60	+58 +36	+71 +36	+90 +36	+34 +12	+47 +12	+22 0	+35 0	+54 0	+87 0	+140 0
>280	≤315	+910 +680	+540 +400	+630 +400	+174 +100	+207 +100	+260 +100	+107 +60	+126 +60	+159 +60	+58 +36	+71 +36	+90 +36	+34 +12	+47 +12	+22 0	+35 0	+54 0	+87 0	+140 0
>315	≤355	+1010 +760	+595 +440	+690 +440	+174 +100	+207 +100	+260 +100	+107 +60	+126 +60	+159 +60	+58 +36	+71 +36	+90 +36	+34 +12	+47 +12	+22 0	+35 0	+54 0	+87 0	+140 0
>355	≤400	+1090 +840	+635 +480	+730 +480	+174 +100	+207 +100	+260 +100	+107 +60	+126 +60	+159 +60	+58 +36	+71 +36	+90 +36	+34 +12	+47 +12	+22 0	+35 0	+54 0	+87 0	+140 0
>400	≤450	+1100 +840	+595 +480	+690 +480	+174 +100	+207 +100	+260 +100	+107 +60	+126 +60	+159 +60	+58 +36	+71 +36	+90 +36	+34 +12	+47 +12	+22 0	+35 0	+54 0	+87 0	+140 0
>450	≤500	+1090 +840	+635 +480	+730 +480	+174 +100	+207 +100	+260 +100	+107 +60	+126 +60	+159 +60	+58 +36	+71 +36	+90 +36	+34 +12	+47 +12	+22 0	+35 0	+54 0	+87 0	+140 0

* In each column, the upper value is the upper dimensional tolerance, and the lower figure is the lower dimensional tolerance.

Hardness Reference Table

(HRC)	(HV)	Brinell hardness 10mm dia. ball bearing 3000kgf load			Rockwell hardness			Rockwell superficial hardness Diamond conic indenter			(HS) Shore hardness	Tensile strength (Approx. value) MPa kgf/mm ²	(HRC) Rockwell C scale hardness
		Standard ball bearing	Tungster carbide ball bearing	(HRA) A scale 60kgf load Diamond conic indenter	(HRB) B scale 100kgf load 1.6mm (1/16in) dia. tube	(HRD) D scale 100kgf load Diamond conic indenter	15-N scale 15kgf load	30-N scale 15kgf load	45-N scale 15kgf load				
68	940	—	—	85.6	—	76.9	93.2	84.4	75.4	97	—	68	
67	900	—	—	85	—	76.1	92.9	83.6	74.2	95	—	67	
66	865	—	—	84.5	—	75.4	92.5	82.8	73.3	92	—	66	
65	832	—	-739	83.9	—	74.5	92.2	81.9	72	91	—	65	
64	800	—	-722	83.4	—	73.8	91.8	81.1	71	88	—	64	
63	772	—	-705	82.8	—	73	91.4	80.1	69.9	87	—	63	
62	746	—	-688	82.3	—	72.2	91.1	79.3	68.8	85	—	62	
61	720	—	-670	81.8	—	71.5	90.7	78.4	67.7	83	—	61	
60	697	—	-654	81.2	—	70.7	90.2	77.5	66.6	81	—	60	
59	674	—	-634	80.7	—	69.9	89.8	76.6	65.5	80	—	59	
58	653	—	-615	80.1	—	69.2	89.3	75.7	64.3	78	—	58	
57	633	—	-595	79.6	—	68.5	88.9	74.8	63.2	76	—	57	
56	613	—	-577	79	—	67.7	88.3	73.9	62	75	—	56	
55	595	—	-560	78.5	—	66.9	87.9	73	60.9	74	2075	55	
54	577	—	-543	78	—	66.1	87.4	71.2	59.8	72	2015	54	
53	560	—	-525	77.4	—	65.4	86.9	70.2	58.6	71	1950	53	
52	544	-500	-512	76.8	—	64.6	86.4	69.4	57.4	69	1880	52	
51	528	-487	-496	76.3	—	63.8	85.9	68.5	56.1	68	1820	51	
50	513	-475	-481	75.9	—	63.1	85.5	67.6	55	67	1760	50	
49	598	-464	-469	75.2	—	62.1	85	66.7	53.8	66	1695	49	
48	584	-451	-455	74.7	—	61.4	84.5	65.8	52.5	64	1635	48	
47	471	-442	-443	74.1	—	60.8	83.9	64.8	51.4	63	1580	47	
46	458	-432	-432	73.6	—	60	83.5	64	50.3	62	1530	46	
45	446	-421	-421	73.1	—	59.2	83	63.1	49	60	1480	45	
44	434	-409	-409	72.5	—	58.5	82.5	62.2	47.8	58	1435	44	
43	423	-400	-400	72	—	57.7	82	61.3	46.7	57	1385	43	
42	412	-390	-390	71.5	—	56.9	81.5	60.4	45.5	56	1340	42	
41	402	-381	-381	70.9	—	56.2	80.9	59.5	44.3	55	1295	41	
40	392	-371	-371	70.4	—	55.4	79.9	58.6	43.1	54	1250	40	
39	382	-362	-362	69.9	—	54.6	79.4	57.7	41.9	52	1215	39	
38	372	-353	-353	69.4	—	53.8	78.8	56.8	40.8	51	1180	38	
37	363	-344	-344	68.9	—	53.1	78.3	55.9	39.6	50	1160	37	
36	354	-336	-336	68.4	-109	52.3	77.7	54.2	38.4	49	1115	36	
35	345	-327	-327	67.9	-108.5	51.5	77.2	53.3	37.2	48	1080	35	
34	336	-319	-319	67.4	-108	50.8	76.6	52.1	36.1	47	1055	34	
33	327	-311	-311	66.8	-107.5	50.0	76.1	51.3	34.9	46	1025	33	
32	318	-301	-301	66.3	-107	49.2	75.6	50.4	33.7	44	1000	32	
31	310	-294	-294	65.8	-106	48.4	75	49.5	32.5	43	980	31	
30	302	-286	-286	65.3	-105.5	47.7	74.5	48.6	31.3	42	950	30	
29	294	-279	-279	64.7	-104.5	47	73.9	47.7	30.1	41	930	29	
28	286	-271	-271	64.3	-104	46.1	73.3	46.8	28.9	41	910	28	
27	279	-264	-264	63.8	-103	45.2	72.8	45.9	27.8	40	880	27	
26	272	-258	-258	62.8	-102.5	44.6	72.2	45	26.7	38	860	26	
25	266	-253	-253	62.4	-101.5	43.8	71.6	44	25.5	38	840	25	
24	260	-247	-247	62	-101	43.1	71	43.2	24.3	37	82		

Material Reference : Stainless Steel Series

● About Stainless Steel

1. Stainless steel is a common name for metal alloys that consist of 10.5% or more Chromium(Cr) and more than 50% Iron(Fe). Generally, an increase of chromium content improves the corrosion resistance of stainless steels. The addition of Ni, Mo, Cu, Al, Si, etc. improves corrosion resistance, mechanical properties, workability, and other properties.
2. Stainless steel is divided into Cr and Cr-Ni series by main elements. The three major classes of stainless steel are martensite, ferrite, and austenitic series. Two additional classes worth mentioning include Duplex (with austenitic and ferritic structures), and precipitation hardening stainless steel, used in certain extreme conditions.

● Categories of Stainless Steel

Category	Cr Series		Cr-Ni Series
Metal Structure	Martensite Series	Ferrite Series	Austenitic Series
Hardening	Quench Hardening	Anti-Quench Hardening	Work Hardening

● Effect of Each Element which Influences Properties

Element	Improved Properties	
C	Low Carbon	Corrosion Resistance (Intergranular Corrosion Resistance)
	High Carbon	Strength, Hardness
Mo	Corrosion Resistance (Pitting Corrosion Resistance)	
Cu	Acidity Resistance	
Ti/Nb	Corrosion Resistance (Intergranular Corrosion Resistance)	
Si/Al	Oxidation Resistance	
S/Se	Cutting Performance	

● Grades and Characteristics of Stainless Steel

Grade	Characteristics
SUS302	Standard grade of 18Cr-8Ni. SUS303 and SUS304 are improvements over SUS302. They exhibit better corrosion resistance and mechanical properties due to the addition of Ni.
SUS303	Cutting performance is improved by adding S and P to SUS302. There is less corrosion resistance, but this is improved by adding Mo.
SUS304 SUS304L	Improved grade of SUS302. Has a lower amount of carbon, better corrosion resistance and improved weldability. The most commonly specified in austenitic stainless steels. SUS304L contains lower carbon amounts than SUS304 and has improved intergranular corrosion resistance and weldability.
SUS316 SUS316L	Better corrosion resistance (pitting corrosion resistance) and acidity resistance due to the addition of Mo. Has great strength and heat resistance. SUS316L contains lower carbon amounts than SUS316 and has improved intergranular corrosion resistance and weldability.
SUSXM7	Work Hardening by cold working is restrained due to the addition of Cu to SUS304.
SUS430	Standard grade of 18Cr steel with better cold working and corrosion resistance. Most widely used ferrite stainless steel due to its low price.
SUS434	Improved corrosion resistance through adding Mo to SUS430.
SUS410	The most widely used martensite stainless steel. Better mechanical properties and corrosion resistance after heat treatment.
SUS403	Smaller percentage of Si and Cr with improved corrosion resistance and toughness after heat treatment. Used for valves, pump shafts, cutlery, bolts, nuts, steam turbine wings, jet engine parts, etc.
SUS416	Improved cutting performance of 13Cr steel due to the addition of S and P. Corrosion resistance is slightly inferior to the standard type.
SUS431	Improved toughness due to the addition of Ni and improved corrosion resistance due to the addition of Cr. Best corrosion resistance in martensite steels in which heat treatment is available. Used for paper making machines, shafts for shipping, airplane parts, etc.
SUS440C	The hardest of stainless steels with superior wear resistance. Used for dice, ball bearings, etc.

Components and Mechanical Properties of Stainless Steel

● About Stainless Steel

Grade	Components (%)										Mechanical Properties		
	C	Si	Mn	P	S	Ni	Cr	Mo	others	Tensile Strength (N/mm ²)	Elongation (%)	Brinell Hardness (HB)	
SUS302	Below 0.15	Below 1.00	Below 2.00	Below 0.045	Below 0.03	8.00-10.00	17.00-19.00	—	—	Above 520	Above 40	Below 187	
SUS303	Below 0.15	Below 1.00	Below 2.00	Below 0.20	Above 0.15	8.00-10.00	17.00-19.00	Below 0.60	—	Above 520	Above 40	Above 187	
SUS304	Below 0.08	Below 1.00	Below 2.00	Below 0.045	Below 0.03	8.00-10.50	18.00-20.00	—	—	Above 520	Above 40	Below 187	
SUS304L	Below 0.03	Below 1.00	Below 2.00	Below 0.045	Below 0.03	9.00-13.00	18.00-20.00	—	—	Above 480	Above 40	Below 187	
SUS316	Below 0.08	Below 1.00	Below 2.00	Below 0.045	Below 0.03	10.00-14.00	16.00-18.00	2.00-3.00	—	Above 520	Above 40	Below 187	
SUS316L	Below 0.03	Below 1.00	Below 2.00	Below 0.045	Below 0.03	12.00-15.00	16.00-18.00	2.00-3.00	—	Above 480	Above 40	Below 187	
SUSXM7	Below 0.08	Below 1.00	Below 2.00	Below 0.045	Below 0.03	8.50-10.50	17.00-19.00	—	Cu:3.00-4.00	Above 480	Above 40	Below 187	

● Ferrite Series

Grade	Components (%)										Mechanical Properties		
	C	Si	Mn	P	S	Ni	Cr	Mo	others	Tensile Strength (N/mm ²)	Elongation (%)	Brinell Hardness (HB)	
SUS430	Below 0.12	Below 0.75	Below 1.00	Below 0.04	Below 0.03	Below 0.60	16.00-18.00	—	—	Above 450	Above 40	Below 187	
SUS434	Below 0.12	Below 1.00	Below 1.00	Below 0.04	Below 0.03	Below 0.60	16.00-18.00	0.75-1.25	—	Above 450	Above 40	Below 187	

● Martensite Series

Grade	Components (%)										Mechanical Properties		
	C	Si	Mn	P	S	Ni	Cr	Mo	others	Tensile Strength (N/mm ²)	Elongation (%)	Brinell Hardness (HB)	
SUS410	Below 0.15	Below 1.00	Below 1.00	Below 0.04	Below 0.03	Below 0.60	11.50-13.50	—	—	Above 540	Above 25	Below 159	
SUS416	Below 0.15	Below 1.00	Below 1.25	Below 0.06	Below 0.15	Below 0.60	12.00-14.00	Below 0.60	—	Above 540	Above 17	Below 159	
SUS440C	0.95-1.20	Below 1.00	Below 1.00	Below 0.04	Below 0.03	Below 0.60	16.00-18.00	Below 0.75	—	Above 780	Below 15	Above 56HRC	

* The numerical values listed above are for reference only; they are not guaranteed under performance conditions.

Material Reference : Aluminum Alloy-Series

Alloy Type	Symbol	Descriptions
Al-Cu series	A2011	2017 and 2024, known as duralumin and super duralumin, are typical of this type, which is almost as strong as steel. This type has superior machinability. 2011, which contains Pb and Bi, is widely used as free-cutting alloy for machine parts. 2014 has a wide range for high-strength forging applications. It is not corrosion resistant because it contains a considerable amount of copper and therefore requires sufficient corrosion prevention processing when exposed to a corrosive environment.
	A2014	
	A2017	
	A2024	
Al-Mn series	A3003	This type, which is alloyed with Mn, maintains the workability and corrosion-resistance of pure aluminum, but has slightly higher strength. It has a wide range of applications including various wares, building materials and containers, 3003 is the most typical alloy of this type. 3004 adds 1% of Mg to the alloy components of 3003, yielding higher strength. 3004 is widely used for aluminum cans, roof boards and door panel materials.
	A3004	
Al-Si series	A4032	4032 is alloyed with Si and has less thermal expansion and better abrasion resistance. In addition, 1% of respective Cu, Ni and Mn are added to improve heat resistance. Better heat resistance and little thermal expansion make this type suitable for forging piston materials.
Al-Mg system	A5005	5005 is a typical type that contains a small amount of Mg. It is used for interior ceiling boards for vehicles, building materials and various ware materials. 5052 is a typical alloy of this type that contains a medium amount of Mg. It is the most common alloy and exhibits medium strength. 5083 contains a large amount of Mg, and has the best strength among non-thermal treatment alloys and superior weldability. It is used as a structural material for marine vessels, vehicles and chemical plants.
	A5052	
	A5083	
Al-Mg-Si series	A6061	Alloys of this type have superior strength, corrosion resistance and are used as structural materials. 6061 is alloyed with a small amount of Cu for better strength with slightly weaker corrosion-resistance, but has superior forgeability and is used for rivet materials and small parts of vehicles. It has the benefit of providing the allowable stress equivalent to that of SS400 steel if proof stress is 254N/mm ² or more and deflection does not cause any design problem. 6063 has lower strength but superior extrusion performance. It is used for structural materials that do not require the strength equivalent to that of 6061.
	A6063	
Al-Zn series	A7075	Alloys of this type are divided into two categories: Al-Zn-Mg-Cu and Al-Zn-Mg. The Al-Zn-Mg-Cu alloys have the highest strength among aluminum alloys. Al-Zn-Mg alloys contain no Cu and are used for welding construction. A typical type of Al-Zn-Mg-Cu series is 7075, which is used for airplanes, sport gears, etc. Al-Zn-Mg alloys have comparatively high strength. The post-welding heat-affected areas recover strength by natural aging that is close to the strength of the original material, thereby providing superior joint efficiency. 7N01 is typical of this type and is used as a structural material for railroad vehicles etc.
	A7N01	

• Chemical Components of Aluminum Alloy

Symbol	Si	Fe	Cu	Mn	Mg	Cr	Zn	Ti	Al	Others
A2011	0.4 or less	0.7 or less	5.0~6.0	—	—	—	0.30 or less	—	Remaining	Pb:0.20~0.6
A2014	0.50~1.2	0.7 or less	3.9~5.0	0.40~1.2	0.2~0.8	0.1 or less	0.25 or less	—	Remaining	Zr+Ti:0.2 or less
A2017	0.20~0.8	0.7 or less	3.5~4.5	0.40~1.0	0.4~0.8	0.1 or less	0.25 or less	—	Remaining	Zr+Ti:0.2 or less
A2024	0.5 or less	0.5 or less	3.8~4.9	0.30~0.9	1.2~1.8	0.1 or less	0.25 or less	—	Remaining	Zr+Ti:0.2 or less
A3003	0.6 or less	0.7 or less	0.05~0.20	1.0~1.5	—	—	0.10 or less	—	Remaining	—
A3004	0.3 or less	0.7 or less	0.25 or less	1.0~1.5	0.8~1.3	—	0.25 or less	—	Remaining	—
A4032	11.0~13.5	1.0 or less	0.50~1.3	—	0.8~1.3	0.1 or less	0.25 or less	—	Remaining	Ni:0.50~1.3
A5005	0.3 or less	0.7 or less	0.2 or less	0.2 or less	0.50~1.1	0.1 or less	0.25 or less	—	Remaining	—
A5052	0.25 or less	0.4 or less	0.1 or less	0.1 or less	2.2~2.8	0.15~0.35	0.10 or less	—	Remaining	—
A5083	0.4 or less	0.4 or less	0.1 or less	0.40~1.0	4.0~4.9	0.05~0.25	0.25 or less	0.15 or less	Remaining	—
A6061	0.40~0.8	0.7 or less	0.15~0.40	0.15 or less	0.8~1.2	0.04~0.35	0.25 or less	0.15 or less	Remaining	—
A6063	0.20~0.6	0.35 or less	0.1 or less	0.1 or less	0.45~0.9	0.1 or less	0.10 or less	0.10 or less	Remaining	—
A7075	0.4 or less	0.5 or less	1.2~2.0	0.3 or less	2.1~2.9	0.18~0.28	5.1~6.1	0.10 or less	Remaining	Zr+Ti:0.25

Temper Designation of Aluminum Alloys

Symbol	Definition	Meaning
F	As fabricated	Products obtained from the manufacturing process with no special adjustment by work hardening or thermal treatment
O	Annealed	Wrought alloys are annealed to achieve the softest state. Cast alloys are annealed for better extension and size stabilization.
H	Work hardened	Work hardened for higher strength, regardless of whether additional thermal treatment to obtain proper softness is carried out.
T	Products with stable temper other than F, O and H, obtained by thermal treatment	Thermal treatment is carried out to obtain stable temper, regardless of whether additional thermal treatment is carried out.

Subdesignation Symbol	Meaning
H1	Work hardened only: Products are only work hardened with no additional thermal treatment in order to obtain prescribed mechanical properties.
H2	Thermally softened in proper manner after work hardened: Products are work hardened to obtain values higher than prescribed and then thermally treated in a proper manner to reduce strength to a prescribed level. The alloys of this temper, which are aged and softened at room temperature, have strength almost equivalent to that of the temper H3. Other alloys of this temper have strength almost equivalent to that of H1 temper, but slightly higher extension.
H3	Stabilization treated after work hardened: Products are work hardened and then stabilized using low temperature heating. This results in slightly reduced strength but better extension. This stabilization treatment is applied only to alloys that contain magnesium, which are gradually aged and softened at room temperature.
T1	Cooled and naturally aged after high temperature processing: Products, such as extruded alloys, are processed at a high temperature, cooled and then naturally aged to a sufficiently stable state. No positive cold working is carried out so correction using cold working has only a small effect on alloys of this type.
T2	Cooled, cold worked, and then naturally aged after high temperature processing: Products, such as extruded alloys, are processed at a high temperature, cooled, positively cold worked and then naturally aged to a sufficiently stable state.
T3	Solution treated, cold worked and then naturally aged: Products are solution treated, cold worked to increase their strength, and then naturally aged to a sufficiently stable state.
T4	Solution treated and then naturally aged: Products are solution treated and naturally aged to a sufficiently stable state. No positive cold working is carried out so correction using cold working has only a small effect on alloys of this type.
T5	Cooled, artificially aged and work hardened after high temperature processing: Products, such as cast alloys or extruded alloys, are processed at a high temperature, cooled, and then artificially aged and work hardened. No positive cold working is carried out so correction using cold working has only a small effect on alloys of this type.
T6	Solution treated, then artificially aged and work hardened: Products are solution treated and artificially aged only. No positive cold working is carried out so correction using cold working has only a small effect on alloys of this type.
T7	Solution treated and then stabilization treated: Products are solution treated, artificially aged and work hardened excessively to obtain strength higher than the maximum specified by the artificial aging conditions and to obtain special mechanical properties.
T8	Solution treated, cooled, and then artificially aged and work hardened: Products are solution treated, cold worked to increase the strength, and then artificially aged and work hardened.
T9	Solution treated, artificially aged and work hardened, and then cold worked: Products are solution treated, artificially aged, strongly work hardened, and then cold worked to increase the strength.

• Mechanical Properties of Aluminum Alloy

Class (JIS Name)	Temper	Tensile Strength (N/mm ²)	Proof Stress (N/mm ²)	Extension (%)	Brinell Hardness (HBS 10/500)	Fatigue Strength (N/mm ²)
A2014	T6	485	415	13	135	125
A2017	O	180	70	22	45	90
A2024	T4	470	325	20	120	140
A3003	O	110	40	30	28	50
A4032	T6	380	315	9	120	110
A5052	H38	290	255	7	77	140
A5083	H116	315	230	16	—	160
A6061	T6	310	275	12	95	95
A6063	T6	240	215	12	73	70
A7075	T6	570	505	11	150	160
A7N01	T5	345	295	15	100	125

* The values shown in the table above are just for reference, but they are not guaranteed values.

● High speed tool steel & Alloy tool steel

JIS	ISO	AISI	BS	DIN	
		ASTM		VDEh	
SKH51	HS 6-5-2	M2	BM2	S 6-5-2	1.3343
SKH55	HS 6-5-2-5	—	BM35	S 6-5-2-5	1.3243
SKS 3	—	—	—	—	1.2419
SKD11	—	D2	BD2	—	1.2379
SKD61	40CrMoV5	H13	BH13	X40CrMoV51	1.2344

● High-carbon chrome bearing steel

JIS	ISO	AISI ASTM	BS	DIN	
SUJ 2	BLor100Cr6	52100	—	100Cr6	1.2067/1.3505

● Carbon steel for machine structural use & Chrome molybdenum steel

JIS	ISO 683/1,10,11 ⁵	AISI SAE	BS 970Part1,3 BS EN 10083-1,2	DIN	
S45C	C45	1045	C45	C45	1.0503
	C45E4	0146	C45E	C45E	1.1191
	C45M2		C45R	C45R	1.1193
S50C	C50	1049	080M50	C50	1.1213
	C50E4		C50	C50E	
	C50M2		C50E	C50R	
			C50R		
S55C	C55	1055	070M55	C55	1.0535/1.1203
	C55E4		C55	C55E	
	E55M2		C55E	C55R	
			C55R		
SCM430	—	4133	—	—	1.7218
SCM435	34CrMo4	4137	34CrMo4	34CrMo4	1.722
	34CrMoS4		34CrMoS4	34CrMoS4	
SCM440	42CrMo4	4140 4142	708M40	42CrMo4	1.7225
	42CrMoS4		709M40	42CrMoS4	
			42CrMo4		
			42CrMoS4		

● Stainless Steel

JIS	ISO TR 15510 L · No.	AISI	BS	DIN	
SUS 303	13	303	303S21	X10CrNiS189	1.4305
SUS 304	6	304	304S31	X5CrNiS1810	1.4301
SUS 430	41	430	430S17	X6Cr17	1.4016
SUS 440C	—	440C	—	X105CrMo17	1.4125

● Aluminum and aluminum alloy extender

JISH4000:88	ISO 6361:90 ISO 209:89	ASTM B209 M:95	BS EN485-2:95 BS EN573-3:95	DIN EN485-2:95 DIN EN573-3:95	
	AlMg2.5	5052	EN AW-5052	EN AW-5052	
	—	6061	EN AW-6061	EN AW-6061	
	AlZn5.5MgCu	7075	EN AW-7075	EN AW-7075	

- Remar ks: : AISI (USA), ASTM (USA), BS (UK), DIN (Germany)
- ISO (International Standard.) JIS (Japan)

If two lubricants incompatible, but mixed to use, would change functionally and physically, such as viscosity, shear stability, oil filtration, and oxidized stability...etc, and also soften lubricant mixed to increase oil leakage. It's better to use same thickener for the mixture of two lubricants.

If two lubricants with different thickeners required to mix, you need to check compatibility of two thickeners first. To avoid mixture of different thickeners is safest.

● Compatibility comparison of different thickeners as follows :

Critical compatible
Compatible
Incompatible
Same lubricant

	Aluminum complex	Barium-based	Calcium-based	Calcium 12-hydroxysebacic acid	Calcium complex	Clay-based	Lithium-based	Lithium 12-hydroxysebacic acid	Lithium complex	Urea-based
Aluminum complex	●	●	●	●	●	●	●	●	●	●
Barium-based	●	●	●	●	●	●	●	●	●	●
Calcium-based	●	●	●	●	●	●	●	●	●	●
Calcium 12-hydroxysebacic acid	●	●	●	●	●	●	●	●	●	●
Calcium complex	●	●	●	●	●	●	●	●	●	●
Clay-based	●	●	●	●	●	●	●	●	●	●
Lithium-based	●	●	●	●	●	●	●	●	●	●
Lithium 12-hydroxysebacic acid	●	●	●	●	●	●	●	●	●	●
Lithium complex	●	●	●	●	●	●	●	●	●	●
Urea-based	●	●	●	●	●	●	●	●	●	●

All GMT Slide Rail Set / Slide Table has been cryogenic processing.

Cryogenic process is to place the part in the medium with temperature under 196°C, followed step by step progress of new technic to improve material character. Found by relevant search, cryogenic process is not only obviously increase on strength and life of black (colour)metal, plastic and china...etc, but also improve the structure evenly. Increase of dimension stability brings huge economic benefit and promising application in aviation, aerospace, optics, creatures, chemistry, machinery, electronic and light industry.

Purpose of cryogenic process

Ex : Comparison of metallographic analysis

Improving physical character (mechanical character) of metal or other material by progress of subzero processing, to raise usage life, efficiency and quality of parts or workpiece.

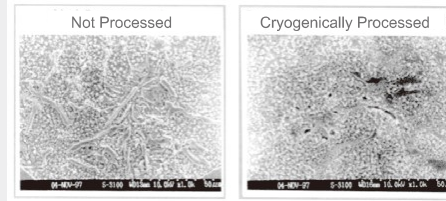

Metallographic analysis before cryogenic process

Metallographic analysis after cryogenic process

Benefic analysis of aluminum alloy after cryogenic process:

Improvement during process or in the end of process:

- (1) Deformation of microstructure stress caused by designed material shape.
- (2) Effectively controlling aging deformation.
- (3) After mechanical testing, mechanism strength has been obviously improved, and perfectly perform the desinged mechanism.

Practical application :

After dissolving aluminum alloy(Duralumin), have it with cryogenic process and unfrozen immediately. It could not only speed up aging, but reduce most of residual stress at same time to improve mechanical character. Found by another info, aluminum alloy casting with cryogenic process has improvement of processed ability.

Material	Parts	Hardness	Durability	Processing life	Dimension stability	Others
SKH	Drill, Cutting, Tools	+	+	+	+	1 time temper
SKD11	Blanking Die, Punch, Cutting Blade,Roller	+	+	+	+	Avoid broken by grinding
SKD61	Aluminum extrusion die	+	+			
SUJ	Rail, Roll Guide	+	+		+	
Inner parts	Bearing, Gear, Bushing, Cam	+	+		+	Avoid broken by grinding
SUS	Austenite(300)	+	+		+	Improvement of Improvement of corrosion resistance
	Martensitic(420J2 , 440)	+	+		+	
	Separated(630 , 631)	+	+	+	+	
18Ni 280Grade	18%Ni type	+	+		+	Speed up sging Speed up sging
	25%Ni type	+	+		+	
Sintering alloy	Cutting tools, Roller, Automobile parts		+	+	+	Reduce residual stress
Cu alloy	Electrode , Fire gate		+		+	
AL alloy	Automatic machinery, precision processing, die manufacture, electronic and precision instrument, SMT, PC board soldering device		+		+	Improvement of processed ability

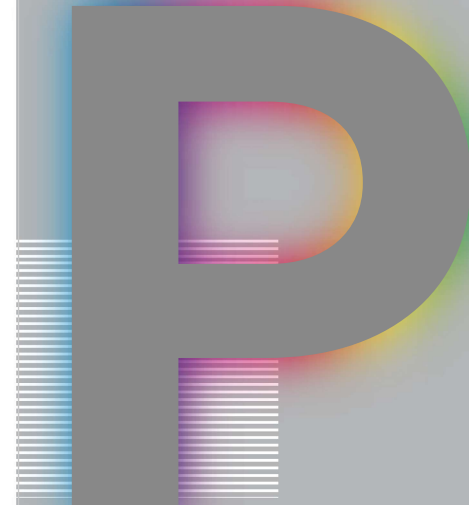

Product Alphabetical
Index Page

Model Number	Page	Model Number	Page	Model Number	Page	Model Number	Page	Model Number	Page
A									
AIB-4-120-120	0198	MC1A-25	0200	MC3C-100	0223	MCS-44W	0235	ML240-ASZ	0085
AIB-4-150-150	0198	MC1A-40	0200	MC3C-150	0223	MCS-46	0235	ML260-ASZ	0085
AIB-4-200-200	0198	MC1A-425	0211	MC3C-150-2	0224	MCS-46W	0235	ML290-ASZ	0085
AIB-6-120-120	0198	MC1A-46C	0207	MC3C-200	0223	MCS-49	0236	MMS-125	0189
AIB-6-150-150	0198	MC1A-46L	0206	MC3C-200-2	0224	MCS-49W	0236	MMS-45	0189
AIB-6-200-200	0198	MC1A-46S	0208	MC3C-250	0223	MCT-41	0248	MMS-65	0189
ASAP-40	0197	MC1A-48M(R)	0213	MC3C-300	0223	MCT-41L	0250	MMS-90	0189
ASAP-60	0197	MC1A-49L	0206	MC3C-300-2	0224	MCT-41W	0248	MMT-38	0188
ASAP-80	0197	MC1A-49S	0208	MC3C-300-3	0225	MCT-41WL	0250	MMT-52	0188
AZB100-1	0196	MC1A-60	0200	MC3C-50	0223	MCT-44	0247	MMT-66	0188
AZB120-1	0196	MC1A-60CL	0205	MC3C-70	0223	MCT-44L	0249	MN1A-12	0173
AZB40-1	0195	MC1A-A40	0203	MC4A-25	0202	MCT-44W	0247	MN1A-15	0173
AZB40-2	0195	MC1A-A60	0203	MC4A-40	0202	MCT-44WL	0249	MN2A-12	0173
AZB60-1	0195	MC1AL-40	0212	MC4A-49S	0210	MCT-46	0247	MN2A-15	0173
AZB80-1	0195	MC1B-140	0215	MC4A-60	0202	MCT-46L	0249	MNE1E	0171
AZB80-2	0196	MC1B-35LG	0261	MC4A-A60	0204	MCT-46W	0247	MNE1E-20	0167
		MC1B-40	0215	MC4AL-40	0212	MCT-46WL	0249	MNE1E-25	0167
		MC1B-60	0215	MC4B-140	0217	MCT-49	0248	MNE1E-40	0167
E									
EAIB-4-120-200	0198	MC1B-60F	0218	MC4B-40	0217	MCT-49L	0250	MNE1E-60	0167
EAIB-4-120-300	0198	MC1B-90	0215	MC4B-60	0217	MCT-49W	0248	MNE2E-20	0169
EAIB-4-150-200	0198	MC1BL-60	0233	MC4B-90	0217	MCT-49WL	0250	MNE2E-25	0169
EAIB-4-150-300	0198	MC1C-100	0219	MC4D-25	0228	MCV100-AS	0283	MNE2E-40	0169
EAIB-4-200-300	0198	MC1C-150	0220	MC4D-2550	0251	MCV-41	0240	MNE2E-60	0169
EAIB-4-300-600	0198	MC1C-150-2	0221	MC4D-40	0228	MCV-41L	0242	MNG1E-20CL	0163
EAIB-4-450-600	0198	MC1C-200	0220	MC4D-60	0228	MCV-41W	0240	MNG1E-25CL	0163
EAIB-6-120-200	0198	MC1C-200-2	0221	MC4E-25	0255	MCV-41WL	0242	MNG1E-40CL	0163
EAIB-6-120-300	0198	MC1C-250	0220	MC4E-40	0255	MCV-44	0239	MNG1E-60CL	0163
EAIB-6-150-200	0198	MC1C-300-2	0222	MC4E-60	0255	MCV-44L	0241	MNG2E-20CL	0165
EAIB-6-150-300	0198	MC1C-50	0219	MC5B-25	0232	MCV-44W	0239	MNG2E-25CL	0165
EAIB-6-200-300	0198	MC1C-70	0219	MC5B-40	0232	MCV-44WL	0241	MNG2E-40CL	0165
EAIB-6-300-600	0198	MC1D-25	0226	MC5B-60	0232	MCV-46	0239	MNG2E-60CL	0165
EAIB-6-450-600	0198	MC1D-2550	0251	MC5D-2550	0251	MCV-46L	0241	MOVW-S1	0313
EMHGS-FN-13	0324	MC1D-40	0226	MC6B-35LG	0262	MCV-46W	0239	MOVW-S2	0313
EMHGS-FN-25	0324	MC1D-40L	0229	MC6D-2550	0251	MCV-46WL	0241	MPS2035-AMR(L)	0115
EMHGS-FP-13	0325	MC1D-60	0226	MC6E-25	0257	MCV-49	0240	MPS20-AMR(L)-18	0114
EMHGS-FP-25	0324	MC1E-25	0253	MC7G-4050C	0260	MCV-49L	0242	MPS40-SMR(L)	0116
EMHGS-SN-13	0325	MC1E-40	0253	MC7G-4050F	0260	MCV-49W	0240	MR110-AR	0181
EMHGS-SN-25	0324	MC1E-60	0253	MCD-41	0238	MCV-49WL	0242	MR38-AR	0181
EMHGS-SP-13	0325	MC1F-40	0263	MCD-41W	0238	MHGS-FN-1/2"	0323	MR50-AR-48	0185
EMHGS-SP-25	0324	MC1G-525C	0258	MCD-44	0237	MHGS-FN-13	0318	MR60-AR	0181
G									
GACT-F-N-6.5	0333	MC1G-525F	0258	MCD-44W	0237	MHGS-FN-15	0319	MR85-AR	0181
GACT-F-P-6.5	0333	MC1G-535C	0259	MCD-46	0237	MHGS-FN-2"	0323	MR85-S	0185
GACT-S-N-6.5	0333	MC1G-535F	0259	MCD-46W	0237	MHGS-FN-25	0320	MRE110-A	0187
GACT-S-P-6.5	0333	MC2A-25	0201	MCD-49	0238	MHGS-FN-25A	0322	MRE40-A	0186
GACT-F-N-13	0334	MC2A-40	0201	MCD-49W	0238	MHGS-FN-50	0321	MRE60-A	0186
GACT-F-P-13	0334	MC2A-46S	0209	MCM-41	0244	MHGS-FN-6.5	0317	MRE85-A	0187
GACT-F-PP-13	0334	MC2A-49S	0209	MCM-41L	0246	MHGS-FP-13	0318	MRL125-AL	0183
GACT-S-N-13	0334	MC2A-60	0201	MCM-41W	0244	MHGS-FP-15	0319	MRL30-AL	0183
GACT-S-P-13	0334	MC2A-60CL	0205	MCM-41WL	0246	MHGS-FP-25	0320	MRL40-AL	0183
GACT-F-N-25	0335	MC2B-140	0216	MCM-44	0243	MHGS-FP-50	0321	MRL60-AL	0183
GACT-F-P-25	0335	MC2B-40	0216	MCM-44L	0245	MHGS-FP-6.5	0317	MRL90-AL	0183
GACT-S-N-25	0335	MC2B-60	0216	MCM-44W	0243	MHGS-SN-13	0318	MTB-40	0191
GACT-S-P-25	0335	MC2B-90	0216	MCM-44WL	0245	MHGS-SN-15	0319	MTB-60	0191
M									
M3E-2000S-L	0285	MC2D-25	0227	MCM-46L	0245	MHGS-SN-25	0320	MTB-80	0191
M3E-2000S-R	0287	MC2D-2550	0251	MCM-46L	0245	MHGS-SN-25A	0322	MTS-125	0193
M5E-2000B-L	0289	MC2D-40	0227	MCM-46W	0243	MHGS-SN-50	0321	MTS-30	0193
M5E-2000B-R	0291	MC2D-60	0227	MCM-46WL	0245	MHGS-SN-6.5	0317	MTS-561-L	0301
M5F-460A561-L	0297	MC2E-48HN	0230	MCM-49	0244	MHGS-SP-13	0318	MTS-561-R	0303
M5F-460A561-R	0299	MC2E-25	0253	MCM-49L	0246	MHGS-SP-15	0319	MTS-60	0193
M6E-2200B-L	0293	MC2E-40	0253	MCM-49W	0244	MHGS-SP-25	0320	MTS-90	0193
M6E-2200B-R	0295	MC2E-60	0253	MCM-49WL	0246	MHGS-SP-50	0321	MX100-AC	0063
MBZ20-AML (R)	0110	MC3B-25	0231	MCS-41	0236	MHGS-SP-6.5	0317	MX100-AC-18	0105
MBZ30-AML (R)	0111	MC3B-40	0231	MCS-41W	0236	MHGS-SP-6.5A(B)	0322	MX100-AS	0063
		MC3B-60	0231	MCS-44	0235	ML230-ASZ	0085	MX100-AS-18	0105

Model Number	Page	Model Number	Page	Model Number	Page	Model Number	Page	Model Number	Page
MX100-SC	0133	MX80-SC	0131	MXYZ-460AL	0309	MY40-AC-18	0095	MYW100-SC	0141
MX100-SC-28	0159	MX80-SC-28	0157	MXYZ-460AR	0311	MY40-AS	0053	MYW100-SS	0139
MX100-SS	0133	MX80-SS	0131	MXYZ50-A	0072	MY40-AS-18	0095	MYW40-AC	0089
MX100-SS-28	0159	MX80-SS-28	0157	MXYZ50-S	0144	MY40-SC	0123	MYW40-AS	0087
MX120-AC	0065	MXG3-30CE	0273	MXYZ60-A	0072	MY40-SC-28	0149	MYW40-SC	0141
MX120-AC-18	0107	MXG3-44CE	0273	MXYZ60-S	0144	MY40-SS	0123	MYW40-SS	0139
MX120-AS	0065	MXG3-57CE	0273	MXYZ70-A	0072	MY40-SS-28	0149	MYW60-AC	0089
MX120-AS-18	0107	MXG4-25CS	0265	MXYZ70-S	0144	MY50-AC	0055	MYW60-AS	0087
MX20-AC	0047	MXG4-40CS	0265	MXYZ80-A	0072	MY50-AC-18	0097	MYW60-SC	0141
MX20-AS	0047	MXG4-40VM	0279	MXYZ80-S	0144	MY50-AS	0055	MYW60-SS	0139
MX25-AC	0049	MXG4-50CE	0275	MXYZA40-A	0073	MY50-AS-18	0097	MYW80-AS	0087
MX25-AC-18	0091	MXG4-60CS	0265	MXYZA60-A	0073	MY50-SC	0125	MYW80-SC	0141
MX25-AS	0049	MXG4-60VM	0279	MXYZA80-A	0073	MY50-SC-28	0151	MYW80-SS	0139
MX25-AS-18	0091	MXG4-68CE	0275	MXYZAR38-A	0074	MY50-SS	0125	MZA1-5060	0177
MX25-SC	0119	MXG4-80VM	0279	MXYZAR60-A	0074	MY50-SS-28	0151	MZA-25	0175
MX25-SC-28	0145	MXG4-86CE	0275	MXYZAR85-A	0074	MY60-AC	0057	MZA2-5060	0177
MX25-SS	0119	MXG5-50CS	0269	MXZ100-A	0071	MY60-AC-18	0099	MZA3-5060	0175
MX25-SS-28	0145	MXG5-50VM	0279	MXZ100-S	0143	MY60-AS	0057	MZA-40	0175
MX30-AC	0051	MXG5-68CS	0269	MXZ120-A	0071	MY60-AS-18	0099	MZA-40H	0175
MX30-AC-18	0093	MXG5-86CS	0269	MXZ25-A	0071	MY60-SC	0127	MZA-60	0175
MX30-AS	0051	MXG6-100VM	0281	MXZ25-S	0143	MY60-SC-28	0153	MZA-60L	0175
MX30-AS-18	0093	MXG6-120CE	0277	MXZ30-A	0071	MY60-SS	0127	MZA-80	0175
MX30-SC	0121	MXG6-35CS	0265	MXZ30-S	0143	MY60-SS-28	0153	MZF-120	0179
MX30-SC-28	0147	MXG6-50VM	0281	MXZ40-A	0071	MY70-AC	0059	MZF-80	0179
MX30-SS	0121	MXG6-60CS	0265	MXZ40-S	0143	MY70-AC-18	0101	MZA3-ACR	0067
MX30-SS-28	0147	MXG6-70CE	0277	MXZ50-A	0071	MY70-AS	0059	MZL25-AS	0069
MX40-AC	0053	MXG6-75VM	0281	MXZ50-S	0143	MY70-AS-18	0101	MZL25-SCR	0135
MX40-AC-18	0095	MNG2E-20CL	0165	MXZ60-A	0071	MY70-SC	0129	MZL25-SS	0137
MX40-AS	0053	MXG6-96CE	0277	MXZ60-S	0143	MY70-SC-28	0155	MZL40-ACR	0067
MX40-AS-18	0095	MNG2E-40CL	0165	MXZ70-A	0071	MY70-SS	0129	MZL40-AS	0069
MX40-SC	0123	MNG2E-60CL	0165	MXZ70-S	0143	MY70-SS-28	0155	MZL40-SCR	0135
MX40-SC-28	0149	MOVW-S1	0313	MXZ80-A	0071	MY80-AC	0061	MZL40-SS	0137
MX40-SS	0123	MOVW-S2	0313	MXZ80-S	0143	MY80-AC-18	0103	MZL60-ACR	0067
MX40-SS-28	0149	MPS2035-AMR(L)	0115	MXZ80-SS	0143	MY80-AS	0061	MZL60-AS	0069
MX50-									